

# Design Guide

---

## N32G003 Series MCU Hardware Design Guide

---

### Introduction

This document details the hardware design checklist for N32G003 series MCUs to provide users with hardware design guidance.

**Nations Technologies ALL Rights Reserved**

## CONTENS

<b>1. N32G003 Series MCU Hardware Design Checklist.....</b>	<b>1</b>
1.1 Introduction to power supply .....	1
1.2 VDD power supply scheme .....	1
1.3 External pin reset circuit .....	1
1.4 Independent ADC Converter.....	1
1.5 IO power-on pulse processing.....	3
1.6 IO withstand voltage .....	4
1.7 Anti-static design .....	5
1.7.1 PCB Design.....	5
1.7.2 ESD Protection Devices.....	5
1.8 Debug Interface.....	6
<b>2. Overall Design Suggestions.....</b>	<b>7</b>
<b>3. Minimum System Reference Design Schematic .....</b>	<b>8</b>
3.1 TSSOP20 .....	8
3.2 QFN20 .....	9
<b>4. PCB LAYOUT Reference.....</b>	<b>10</b>
<b>5. Typical failure analysis.....</b>	<b>11</b>
5.1 Short circuit between power pins and ground.....	11
5.2 GPIO damage.....	11
5.3 ADC sampling inaccurate .....	11
<b>6. History Version .....</b>	<b>12</b>
<b>7. Notice .....</b>	<b>13</b>

# 1. N32G003 Series MCU Hardware Design Checklist

## 1.1 Introduction to power supply

The operating voltage (VDD) of N32G003 series chips is 1.8V~5.5V. Mainly: VDD pins. For details, please refer to the relevant datasheet

## 1.2 VDD power supply scheme

VDD is the main power supply of MCU and must be powered by a stable external power supply. The voltage range is 1.8V~5.5V. VDD pins need to place a 0.1uF and a 4.7uF decoupling capacitors nearby. For the specific design of the decoupling capacitor, please refer to the reference design schematic diagram of the minimum system of each package in Chapter 3.

## 1.3 External pin reset circuit

A system reset occurs when a low level (external reset) occurs on the NRST pin. The external NRST pin reset reference circuit is as follows

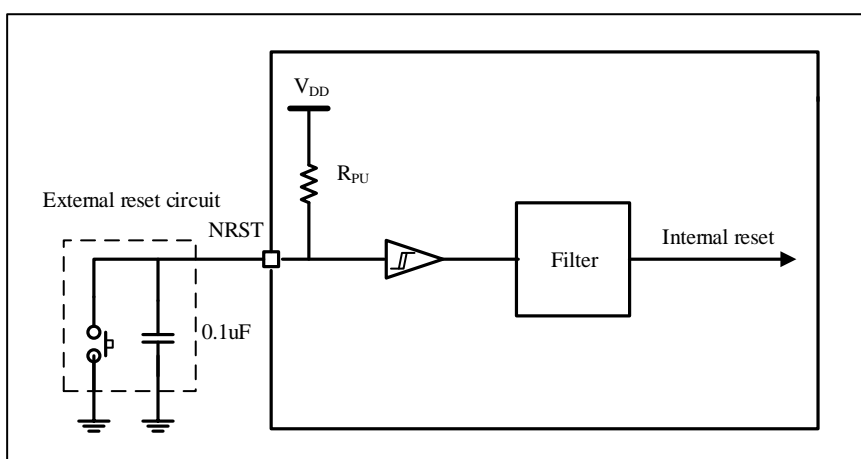

Figure 1-1 System reset diagram

Note: The reset pin NRST cannot be left floating in the design, and the external capacitor 0.1uF is given as a typical reference value. If the reset time needs to be accelerated, the NRST pin can be pulled up externally, and the typical value of the pull-up resistor is 10K. In addition, the user can decide whether to add a reset button according to the actual needs of the product.

## 1.4 Independent ADC Converter

Regarding the ADC circuit design, please pay attention to the following points:

- 1) When using ADC sampling, it is recommended to shorten the external wiring distance;
- 2) It is recommended to keep away from some high frequency inversion signals around the input signal

of ADC;

- 3) During ADC conversion, the chip does not support modifying the ADC configuration. If you need to modify the configuration, you need to wait for the current conversion to end or turn off the ADC before configuring;
- 4) When a certain ADC channel is used, negative voltage (such as -0.2V) cannot be applied to other unused ADC sampling channels. If this negative voltage is applied, the voltage of the normally sampled ADC channel will be pulled down, resulting in sampling data is inaccurate;
- 5) When a certain ADC channel is used, high voltage (greater than VDD voltage) cannot be applied to other unused ADC sampling channels. If this high voltage is applied, the voltage of the normally sampled ADC channel will be pulled up, resulting in the read Data is inaccurate.
- 6) When using ADC, the maximum value of RAIN cannot be too large, and it needs to comply with the following formula:

$$R_{AIN} < \frac{T_s}{f_{ADC} \times C_{ADC} \times \ln(2^{N+2})} - R_{ADC}$$

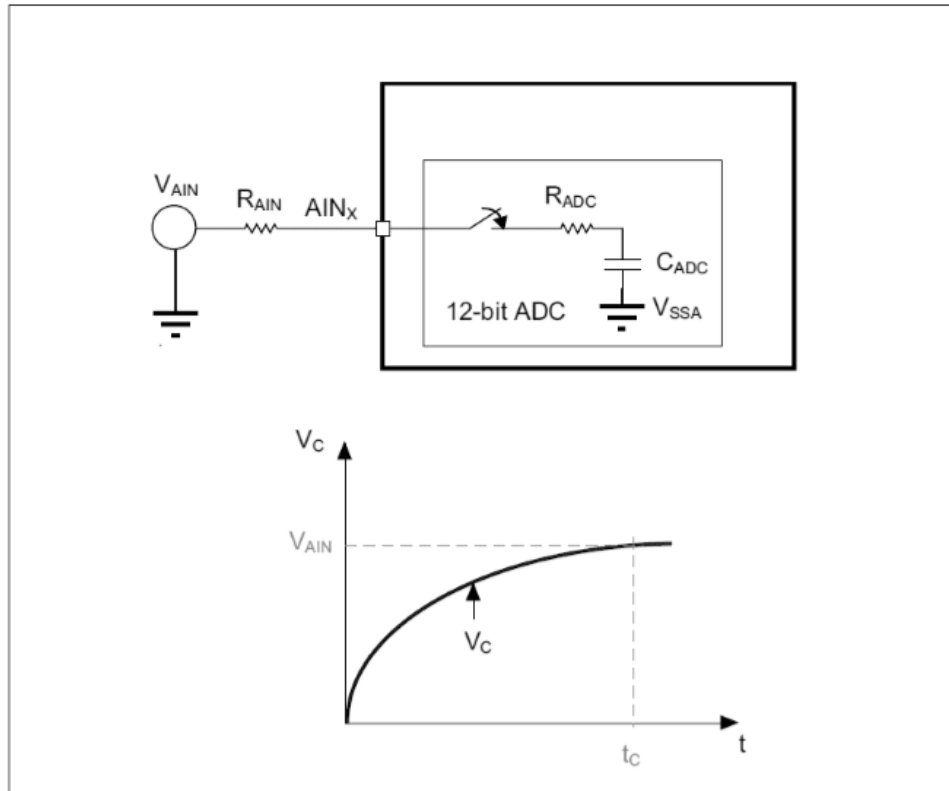

Figure 1-2 Influence of series resistance of ADC input port

The following figure shows the relationship between external input impedance and sampling time: (Maximum allowable error = 1/4LSB, 12-bit resolution, ADC clock frequency = 24MHZ)

Resolution	Rin (kΩ)	Minimum sampling time (ns)
12-bit	1	500
	1.2	583
	2	833
	3.6	1250
	8.26	2333
	10	3000
	18	5000
	26.9	7583
	35.9	10000
	61.9	15833

Figure 1-3 The relationship between ADC external input impedance and sampling time

## 1.5 IO power-on pulse processing

During the power-on process, because the IO is in a high-impedance state and the internal circuit coupling characteristics, a high-level pulse will appear on the IO at the moment of power-on (the actual high-pulse voltage value should be measured by the user). If the pulse will affect its application, it is recommended to add an appropriate capacitor (1nF~100nF) or an appropriate pull-down resistor (10K~100K) on the corresponding IO.

The following picture shows the waveform of IO (PA9) during the power-on process of the development board N32G003F5S7-STB V1.0:

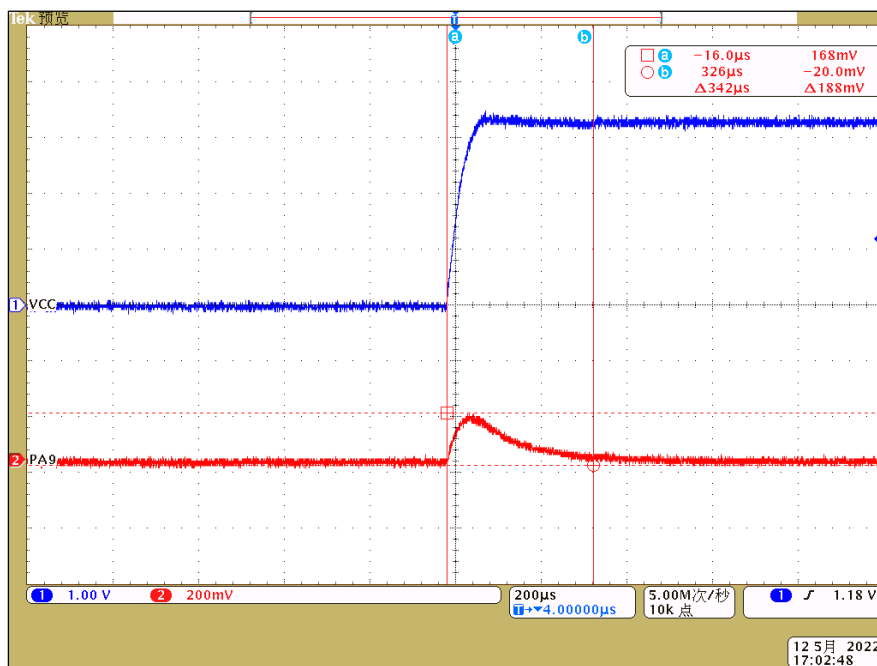

Figure 1-4 IO (PA9) waveform during power-on

The following picture shows the waveform of the IO (PA9) plus a 10K pull-down resistor during the power-on process of the development board N32G003F5S7-STB V1.0:

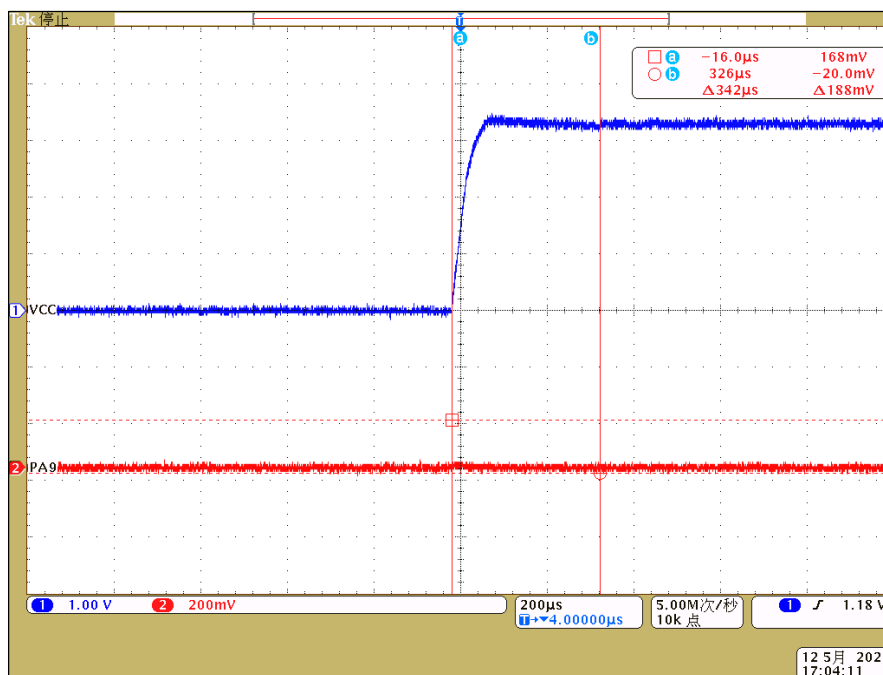

Figure 1-5 Waveform after IO (PA9) plus pull-down resistor during power-on process

## 1.6 IO withstand voltage

When using the chip, please pay attention to the withstand voltage value of each IO. In the I/O column defined by pin multiplexing in the datasheet, TC: Standard 5V IO is marked

Package <sup>Ⓐ</sup>		Pin name(function after reset) <sup>Ⓐ</sup>	Type <sup>(1)</sup> <sup>Ⓐ</sup>	I/O structure <sup>(2)</sup> <sup>Ⓐ</sup>	Alternate functions <sup>Ⓐ</sup>	
TSSOP20 <sup>Ⓐ</sup>	QFN20 <sup>Ⓐ</sup>				Alternate functions <sup>Ⓐ</sup>	Additional functions <sup>Ⓐ</sup>
1 <sup>Ⓐ</sup>	18 <sup>Ⓐ</sup>	PA14 <sup>Ⓐ</sup>	I/O <sup>Ⓐ</sup>	TC <sup>Ⓐ</sup>	TIM1_CH2 <sup>↓</sup> TIM3_CH1 <sup>↓</sup> TIM3_CH2 <sup>↓</sup> TIM1_CH4 <sup>↓</sup> TIM1_ETR <sup>↓</sup> UART1_TX <sup>↓</sup> SPI_SCK <sup>↓</sup> BEEP <sup>Ⓐ</sup>	AIN6 <sup>Ⓐ</sup>
2 <sup>Ⓐ</sup>	19 <sup>Ⓐ</sup>	PB0 <sup>Ⓐ</sup>	I/O <sup>Ⓐ</sup>	TC <sup>Ⓐ</sup>	UART1_TX <sup>↓</sup> SPI_MISO <sup>↓</sup> TIM1_CH1 <sup>↓</sup> BEEPN <sup>↓</sup> EVENT_OUT <sup>Ⓐ</sup>	AIN7 <sup>↓</sup> COMP_INP <sup>Ⓐ</sup>
3 <sup>Ⓐ</sup>	20 <sup>Ⓐ</sup>	PB1 <sup>Ⓐ</sup>	I/O <sup>Ⓐ</sup>	TC <sup>Ⓐ</sup>	UART1_RX <sup>↓</sup> SPI_MOSI <sup>↓</sup> TIM1_CH4 <sup>↓</sup> TIM3_ETR <sup>↓</sup> EVENT_OUT <sup>Ⓐ</sup>	AIN8 <sup>↓</sup> COMP_INM <sup>Ⓐ</sup>

Figure 1-6 I/O structure defined by datasheet pin multiplexing

**Note:** TC: Standard 5V IO; when using the chip, pay attention to the impact of signals higher than 5V on IO.

## 1.7 Anti-static design

### 1.7.1 PCB Design

For the PCB design of ordinary two-layer boards, it is recommended to do wrapping around the signal lines, and try to cover the edges of the PCB as much as possible. If the cost allows, it can be designed with a four-layer board or a multi-layer board. In a multi-layer PCB, the ground plane acts as an important charge source, which can offset the charge on the electrostatic discharge source, which is conducive to reducing the electrostatic field band. The ground plane of the PCB can also be used as a shield for the signal line (of course, the larger the opening of the ground plane, the lower the shielding effectiveness). In addition, if a discharge occurs, since the ground plane of the PCB board is large, the charge is easily injected into the ground plane, rather than into the signal line. This will help protect the component, because the charge can be drained before causing component damage.

### 1.7.2 ESD Protection Devices

In the actual product design, the chip itself has a certain anti-static ability. The static level of N32G003 series MCU ESD (HBM) mode is +/-4KV, but if there is a higher ESD protection level requirement, and the pins of the chip need Direct external connection is used as the output or input port of the product. At this time, the pins of the chip are directly exposed to the outermost part of the product, and cannot be isolated by laying the ground or other means. Under this condition, it is generally necessary to consider an external ESD protection device.

TVS diode is a typical ESD protection device. The following is an example of a typical connection method.

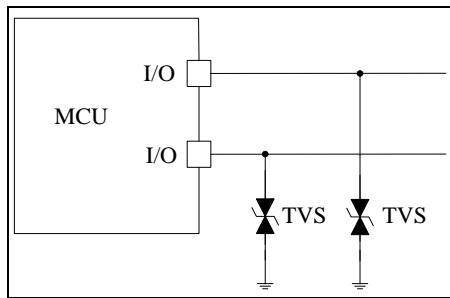

Figure 1-7 TVS connection on I/O pins

## 1.8 Debug Interface

N32G003 series chips support serial (SWD) debug interface, please refer to the relevant user manual for detailed application.

Debug Signal	GPIO Pins
SWDIO	PA8
SWCLK	PA9

Table 1-1 Debug Interface

## 2. Overall Design Suggestions

### 1) Printed circuit board

It is recommended to use a multi-layer printed circuit board with a dedicated independent ground plane (VSS) and a dedicated independent power supply plane (VDD), which can provide good coupling performance and shielding effect. In practical applications, if a multi-layer printed circuit board cannot be used considering the economical reason, a good grounding and power supply structure must be ensured when designing the circuit.

### 2) Device location

In PCB design, different circuits need to be laid out separately according to the different effects of each device on EMI. For example, high-current circuits, low-voltage circuits, and high-frequency devices. Thereby reducing cross-coupling on the PCB.

### 3) Ground and power supply (VSS, VDD)

Each module (analog circuit, digital circuit, low-sensitivity circuit) should be grounded separately, the digital ground and the analog ground should be separated, and all the grounds should be connected together at one point eventually. According to the size of the printed circuit board current, try to increase the width of the power line to reduce the loop resistance. At the same time, the direction of the power wire and the ground wire should be as consistent as possible with the direction of the current, and the power source should be as close to the ground wire as possible to reduce the area of the loop. This helps to enhance noise immunity. The area without devices on the PCB needs to be filled with ground to provide good shielding effect

### 4) Decoupling

All power pins need to be properly connected to power. These connections, including pads, wires, and vias, should have as low impedance as possible. The method of increasing the wiring width is usually adopted, and decoupling capacitors must be placed close to the chip for each pair of VDD and VSS pins. The figure below shows a typical layout of the power/ground pins.

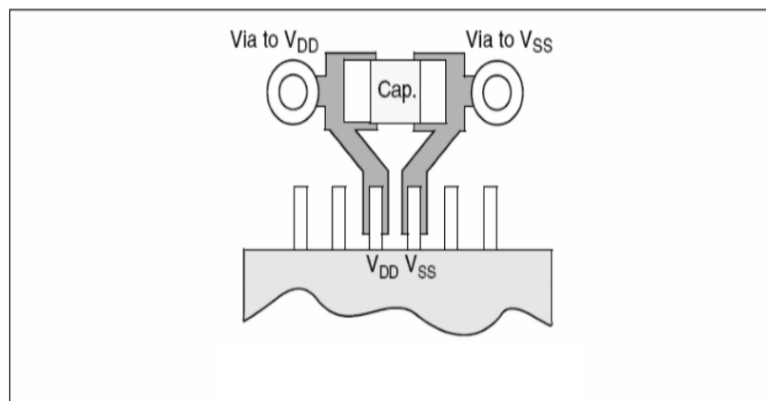

Figure 2-1 Typical layout of VDD/VSS pins

### 3. Minimum System Reference Design Schematic

#### 3.1 TSSOP20

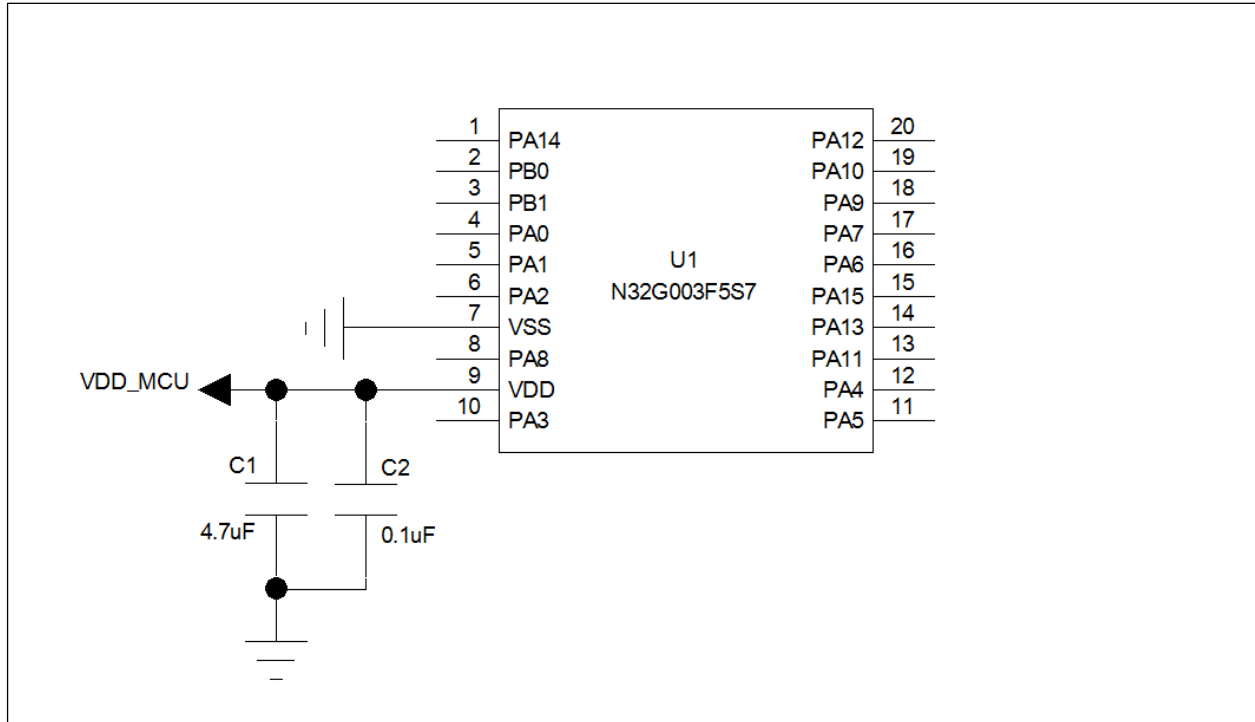

Figure 3-1 N32G003 Series TSSOP20 Package Minimum System Reference Design Schematic

### 3.2 QFN20

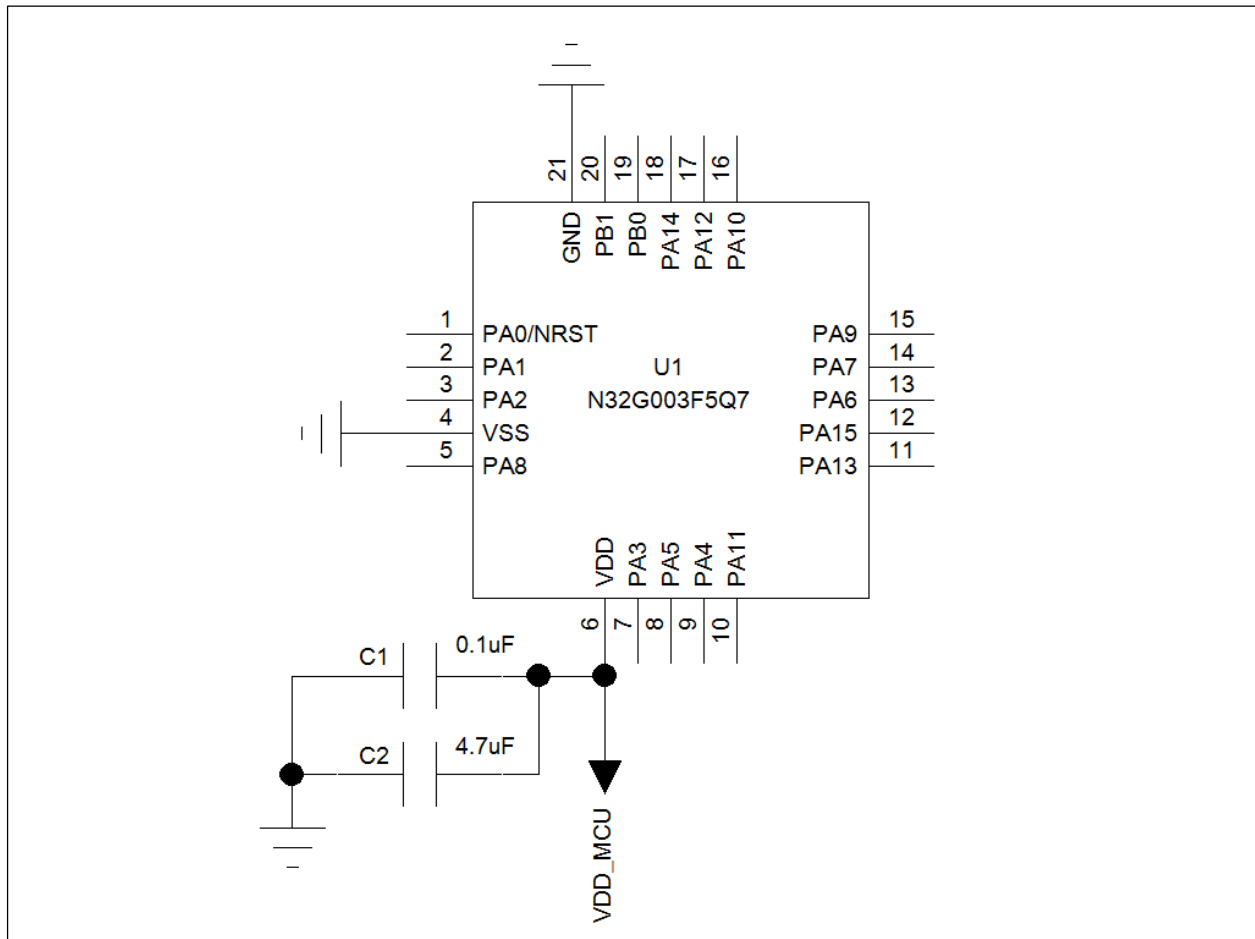

Figure 3-2 N32G003 Series QFN20 Package Minimum System Reference Design Schematic

Figure 3-2~Figure 3-2 is the reference design schematic diagram of the minimum system of each package of N32G003 series, which mainly reflects the design of power supply decoupling capacitor.

## 4. PCB LAYOUT Reference

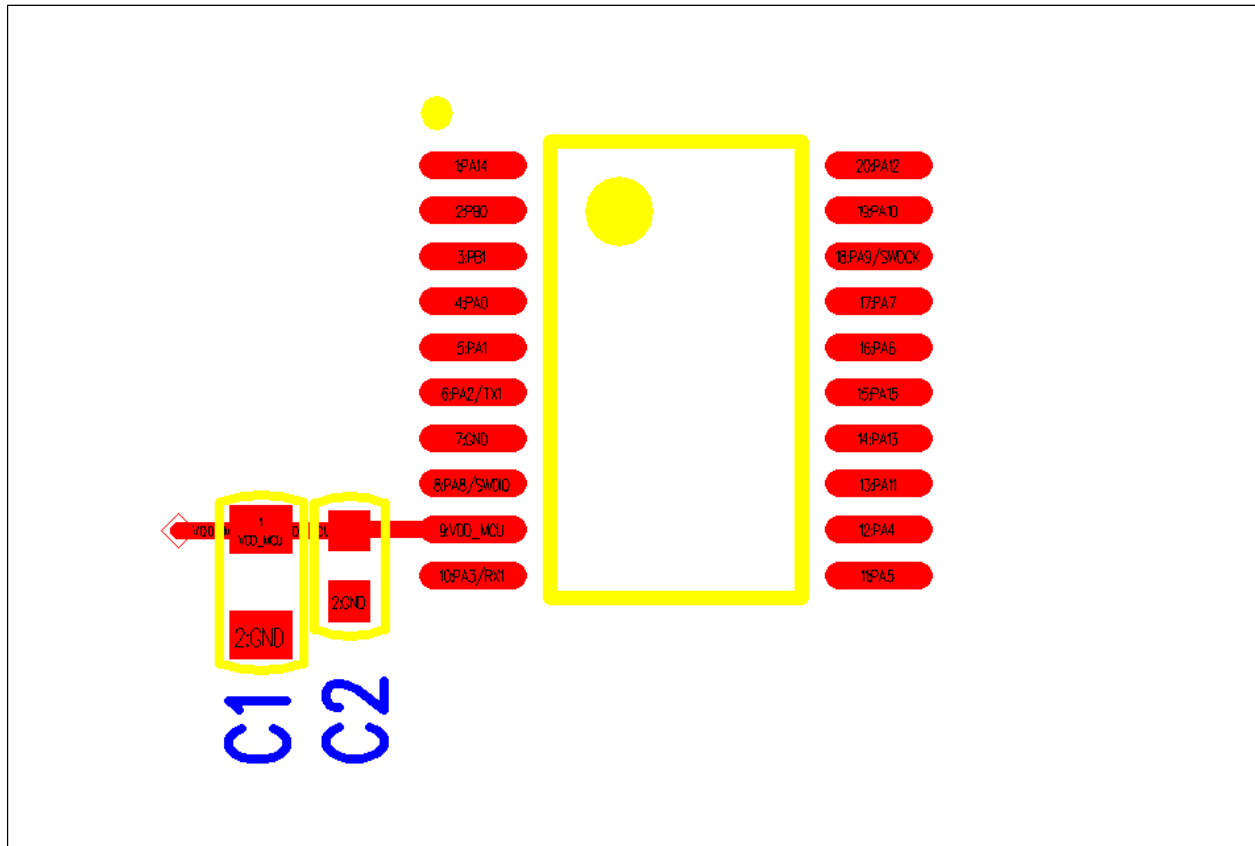

Figure 4-1 N32G003 series TSSOP20 package PCB LAYOUT reference diagram

During PCB LAYOUT design, decoupling capacitors need to be placed near each power pin.

## 5. Typical failure analysis

The common problems and analysis methods encountered by customers in the process of using the chip are described as follows

### 5.1 Short circuit between power pins and ground

**Problem Description:**

The VDD pin of the chip is short-circuited with the GND test, and the chip is abnormally hot after power-on.

**Problem check:**

- 1) Whether the VDD decoupling capacitor has insufficient withstand voltage to cause the capacitor to break down and short circuit.
- 2) When the product starts up, whether the VDD voltage exceeds the specified maximum value.
- 3) Whether there is an overshoot voltage exceeding the maximum value of VDD during the operation of the product.
- 4) In the process of production and use, whether there is static electricity that causes chip damage.

### 5.2 GPIO damage

**Problem Description:**

The chip GPIO cannot output a high level or a low level normally, the GPIO is used as an input to detect the level error, the VIH or VIL test value is abnormal, and the pin impedance is abnormal.

**Problem check:**

- 1) Whether the external input voltage to the chip GPIO exceeds the maximum value, such as the 5V-tolerant I/O input voltage exceeding 5V.
- 2) Whether there is a high voltage input to the GPIO port during product production and testing.
- 3) In product design, whether there is a high-voltage signal near the GPIO trace coupled to the GPIO input port.
- 4) In the process of production and use, whether there is static electricity that causes chip damage.

### 5.3 ADC sampling inaccurate

**Problem Description:**

When sampling the voltage at the ADC input port of the chip, the sampling voltage is inaccurate.

**Problem check:**

Refer to Section 1.4 to confirm whether the hardware and software settings meet the requirements of ADC considerations.

## 6. History Version

Version	Date	Remark
V1.0.0	2022-12-16	Create documentation

## 7. Notice

This document is the exclusive property of NSING TECHNOLOGIES PTE. LTD. (Hereinafter referred to as NSING). This document, and the product of NSING described herein (Hereinafter referred to as the Product) are owned by NSING under the laws and treaties of Republic of Singapore and other applicable jurisdictions worldwide. The intellectual properties of the product belong to NSING Technologies Inc. and NSING Technologies Inc. does not grant any third party any license under its patents, copyrights, trademarks, or other intellectual property rights. Names and brands of third party may be mentioned or referred thereto (if any) for identification purposes only. NSING reserves the right to make changes, corrections, enhancements, modifications, and improvements to this document at any time without notice. Please contact NSING and obtain the latest version of this document before placing orders. Although NSING has attempted to provide accurate and reliable information, NSING assumes no responsibility for the accuracy and reliability of this document. It is the responsibility of the user of this document to properly design, program, and test the functionality and safety of any application made of this information and any resulting product. In no event shall NSING be liable for any direct, indirect, incidental, special, exemplary, or consequential damages arising in any way out of the use of this document or the Product. NSING Products are neither intended nor warranted for usage in systems or equipment, any malfunction or failure of which may cause loss of human life, bodily injury or severe property damage. Such applications are deemed, Insecure Usage<sup>7</sup>. Insecure usage includes, but is not limited to: equipment for surgical implementation, atomic energy control instruments, airplane or spaceship instruments, all types of safety devices, and other applications intended to supporter sustain life. All Insecure Usage shall be made at user's risk. User shall indemnify NSING and hold NSING harmless from and against all claims, costs, damages, and other liabilities, arising from or related to any customer's Insecure Usage Any express or implied warranty with regard to this document or the Product, including, but not limited to. The warranties of merchantability, fitness for a particular purpose and non-infringement are disclaimed to the fullest extent permitted by law. Unless otherwise explicitly permitted by NSING, anyone may not use, duplicate, modify, transcribe or otherwise distribute this document for any purposes, in whole or in part.