

N32H474xC/xE

Datasheet

N32H474 series adopts a 32-bit ARM Cortex-M4F core, with a maximum operating frequency of 240MHz, supporting floating-point unit and DSP instructions. It integrates up to 512-KB embedded flash, 192-KB SRAM (including 32-KB CCM SRAM), and 4-KB Backup SRAM. It also integrates 4x 12bit 4.7MSPS ADCs, 8x 12bit DAC, 4x PGA, 7x COMP, USB FS Device, U(S)ART, I2C, SPI, CAN-FD, Ethernet, and other communication interfaces. It supports FEMC, xSPI high-speed storage interfaces, I2S audio interface, super high-resolution timer, multiple advanced control timers, general timers, basic timers, low-power timers. It also features a built-in hardware acceleration engine for cryptographic algorithms, supporting AES/TDES, SHA, SM3, SM4, MD5 algorithms, TRNG true random number generator, and CRC16/32.

Key Features

● CPU Core

- 32-bit ARM Cortex-M4F + FPU, single-cycle hardware multiplication and division instruction, support DSP instruction and MPU
- Built-in 8-KB instruction Cache supporting Flash acceleration unit for zero-wait program execution
- Frequency up to 240 MHz, 300 DMIPS

● Memories

- 512-KByte of embedded Flash memory with ECC
 - ◆ Supports encryption, multi-user partition and data protection
 - ◆ 10,000 erase/write cycles and 10-years data retention
- 160-KByte of general SRAM with hardware parity checking
- 32-KByte of CCM SRAM with ECC, defaults to general SRAM after power-up, configurable as CCM SRAM
- 4-KByte of Backup SRAM with ECC available in Standby mode

● Power Modes

- Run mode: 45 mA/MHz@240 MHz (peripherals off, 3.3 V@25°C)
- Stop0 mode: SRAM and all registers can be configured to retention, RTC run
- Standby mode: typical value 6uA, all backup registers and Backup SRAM retained, all IOs retained, optional RTC run

● Clock

- HSE: 4MHz~32MHz high-speed external crystal oscillator
- LSE: 32.768KHz low-speed external crystal oscillator
- Built-in multiple high speed PLLs
- MCO: Supports 2-channel clock outputs, which can be configured independently as clock output
- HSI: High-speed internal RC 8MHz, with an accuracy of -1.5% to +2% across the full temperature range.
- LSI: Low-speed internal RC 32KHz, with an accuracy of +/-10% across the full temperature range.

● Reset

- Supports power-on/brown-out/external pin reset
- Supports watchdog reset

- Supports programmable voltage detection
- **GPIOs**
 - Up to 107 GPIOs
- **Communication Interfaces**
 - 1x USB2.0 FS Device interface, built-in PHY, supports crystal-less mode
 - 6x SPI interfaces, 2x I2S interfaces, support half/full duplex mode, multiplexed with SPI interfaces
 - U(S)ART interfaces
 - ◆ 4x USART interfaces (support ISO7816, IrDA, LIN)
 - ◆ 4x UART interfaces
 - ◆ TX/RX of USART3/UART5/UART8 can be mapped to all pins
 - 4x I2C interfaces(Master/Slave) with speed up to 1 MHz where slave mode support dual address response
 - 3x CAN-FD bus interface, TX/RX can be mapped to all pins
- **High Performance Analog Interfaces**
 - 4x 12bit ADCs with 4.7Msps
 - ◆ Multiple precision configuration, support 12-bit, 10-bit, 8-bit, 6-bit sampling precision, resolution up to 16-bit with hardware oversample
 - ◆ Up to 16 external single-ended input channels, 3 internal single-ended input channels, support differential mode and single-ended mode
 - 8x 12bit DAC
 - ◆ DAC1~4: Support 1 internal output channel and 1 external output channel, with a sampling rate of 1Msps. Support output channel buffered/unbuffered modes.
 - ◆ DAC5~8: Support 1 internal output channel and 1 external output channel, with a sampling rate of 15Msps. Only support output channel buffered/unbuffered modes.
 - 4x rail-to-rail PGAs, support differential mode and single-ended mode
 - 7x high-speed comparators (COMP)
 - Supports 1 reference voltage VREFBUF (2.048V/2.5V/2.9V configurable)
 - 1x temperature sensor
- **High Speed External Memory Interfaces**
 - 1x xSPI interface, supporting external SRAM, PSRAM and Flash, supporting XIP
 - 1x FEMC (Flexible External Memory Controller) interface, supporting external SRAM, PSRAM, NOR Flash and NAND Flash, 8/16-bit data bus width configurable
- **CORDIC Mathematical hardware accelerator for motor control functions**
- **Built-in filter mathematical accelerator FMAC, supporting FIR, IIR filtering**
- **DMA Controllers**
 - 2x DMA controller

- Each controller supports 8 channels
- Channel source address and destination address can be configured arbitrarily
- **RTC real-time clock**
 - Supports leap-year calendar, alarm event, periodic wake up
 - Supports internal and external clock calibration
- **Timers**
 - 1x 16bit super high-resolution timer (SHRTIM1)
 - ◆ Supports 6x 16-bit timer units, each timer unit has 2 independent channels, with a maximum control precision of 125ps.
 - ◆ Supports 12 independent PWM outputs or 6 pairs of complementary PWM outputs.
 - 3x 16-bit advanced control timers with maximum control precision of 5 ns
 - ◆ Support input capture, complementary output, quadrature encoder input etc.
 - ◆ Each has 6 independent channels, 4 of which support 4 pairs of complementary PWM output.
 - 10x 16-bit general purpose timers (GTIM1~10)
 - ◆ GTIM1~7, with a maximum control precision of 5.56ns, each timer has up to 4 independent channels, each channel supports input capture, output comparison, PWM generation, and single-pulse mode output.
 - ◆ GTIM8~10, with a maximum control precision of 5ns, each timer has up to 4 independent channels, each channel supports input capture, output comparison, PWM generation, and single-pulse mode output, only channel 1 supports complementary output with dead time, supports break input.
 - 2x 32-bit basic timers
 - 2x 16-bit low-power timer, can operate in Stop0 and Standby mode.
 - 1x 24-bit SysTick timer.
 - 1x 14-bit Window Watchdog (WWDG)
 - 1x 12-bit Independent Watchdog (IWDG)
- **Programming Methods**
 - Support SWD/JTAG debugging interface.
 - Support UART and USB Bootloader
- **Security Features**
 - Flash encryption, multi-user partition management unit (SMPU)
 - Supports write protection (WRP), multiple read protection (RDP) levels (L0/L1/L2)
 - Built-in hardware acceleration engine for cryptographic algorithm
 - Supports AES/TDES, SHA, SM3, SM4, and MD5 algorithms
 - True random number generator(TRNG)
 - CRC16/32 operation

- Supports secure boot, program encryption download, secure firmware update
- Supports external clock failure detection, anti-tamper detection.
- **96-bit UID and 128-bit UCID**
- **Operating Conditions**
 - Operating voltage range: 1.8V~3.6V
 - Operating temperature range: -40°C ~ 105°C/125°C
 - ESD: ± 4 KV (HBM model), ± 1 KV (CDM model)
 - EFT: EFT: VDD (+/-4KV, level A), I/O (+/-2KV, level A)
- **Packages**
 - QFN32(5mm x 5mm)
 - UQFN48(7mm x 7mm)
 - LQFP48(7mm x 7mm)
 - LQFP64(10mm x 10mm)
 - LQFP80(12mm x 12mm)
 - LQFP100(14mm x 14mm)
 - LQFP128(14mm x 14mm)

Contents

1	INTRODUCTION.....	11
1.1	PRODUCT CONFIGURATIONS	12
2	FUNCTIONAL OVERVIEW	14
2.1	PROCESSOR CORE	14
2.2	MEMORIES	14
2.2.1	Embedded FLASH Memory	16
2.2.2	Embedded SRAM	16
2.2.3	Nested Vector Interrupt Controller (NVIC)	16
2.3	EXTENDED INTERRUPT/EVENT CONTROLLER (EXTI)	16
2.4	CLOCK SYSTEM.....	16
2.5	BOOT MODES	18
2.6	POWER SUPPLY SCHEME.....	19
2.7	RESET	19
2.8	PROGRAMMABLE VOLTAGE DETECTOR	19
2.9	LOW POWER MODE.....	19
2.10	DIRECT MEMORY ACCESS (DMA).....	20
2.11	REAL TIME CLOCK (RTC).....	21
2.12	TIMERS AND WATCHDOGS	21
2.12.1	Super High-resolution Timer (SHRTIM)	22
2.12.2	Basic Timer (BTIM1~2).....	23
2.12.3	General-Purpose Timer (GTIM1~7).....	23
2.12.4	General-Purpose Timer (GTIM8~10).....	24
2.12.5	Advanced Control Timer (ATIM1~3)	24
2.12.6	Low Power Timer (LPTIM1~2)	25
2.12.7	SysTick Timer (SysTick).....	26
2.12.8	Watchdog (WDG)	26
2.13	I ² C BUS INTERFACE	26
2.14	UNIVERSAL SYNCHRONOUS/ASYNCHRONOUS TRANSCEIVER (USART).....	27
2.15	SERIAL PERIPHERAL INTERFACE/INTER-INTEGRATED SOUND INTERFACES (SPI/I ² S)	28
2.16	EXPANDED SERIAL PERIPHERAL INTERFACE(XSPI)	29
2.17	CONTROLLER AREA NETWORK (FDCAN)	30
2.18	FLEXIBLE EXTERNAL MEMORY CONTROLLER (FEMC).....	30
2.19	UNIVERSAL SERIAL BUS FULL-SPEED DEVICE INTERFACE (USB_FS).....	31
2.20	FILTER MATH ACCELERATOR (FMAC)	32
2.21	CORDIC CO-PROCESSOR (CORDIC)	32
2.22	GENERAL-PURPOSE INPUT/OUTPUT INTERFACE (GPIO).....	32
2.23	ANALOG/DIGITAL CONVERTER (ADC)	33
2.24	ANALOG COMPARATOR (COMP).....	35
2.25	DIGITAL/ANALOG CONVERTER (DAC)	35
2.26	PROGRAMMABLE GAIN AMPLIFIER (PGA).....	36
2.27	VOLTAGE REFERENCE BUFFER (VREFBUF).....	36
2.28	CYCLIC REDUNDANCY CHECK CALCULATION UNIT (CRC).....	36
2.29	SECURE ALGORITHM CO-PROCESSOR (SAC)	37
2.30	UNIQUE DEVICE SERIAL NUMBER (UID)	37
2.31	SERIAL SINGLE-WIRE JTAG DEBUG PORT (SWJ-DP).....	37
3	PINOUTS AND PIN DESCRIPTION.....	39
3.1	PINOUTS	39
3.1.1	QFN32	39
3.1.2	UQFN48.....	40
3.1.3	LQFP48.....	41
3.1.4	LQFP64.....	42
3.1.5	LQFP80.....	43
3.1.6	LQFP100.....	44
3.1.7	LQFP128.....	45
3.2	PIN DESCRIPTION	46

4	ELECTRICAL CHARACTERISTICS.....	63
4.1	PARAMETER CONDITIONS	63
4.1.1	Minimum and Maximum Values	63
4.1.2	Typical Values	63
4.1.3	Typical Curves	63
4.1.4	Loading Capacitor.....	63
4.1.5	Pin Input Voltage	63
4.1.6	Power Supply Scheme	65
4.1.7	Current Consumption Measurement	66
4.2	ABSOLUTE MAXIMUM RATING	66
4.3	OPERATING CONDITIONS	67
4.3.1	General Operating Conditions	67
4.3.2	Operating Conditions at Power-on and Power-off.....	67
4.3.3	Embedded Reset and Power Control Module Characteristics.....	67
4.3.4	Embedded Reference Voltage.....	69
4.3.5	Power Supply Current Characteristics	69
4.3.6	External Clock Source Characteristics	74
4.3.7	Internal Clock Source Characteristics.....	77
4.3.8	Wake Up Time from Low Power Mode	78
4.3.9	PLL Characteristics.....	78
4.3.10	FLASH Memory Characteristics	79
4.3.11	Absolute Maximum (Electrical Sensitivity)	80
4.3.12	I/O Port Characteristics	81
4.3.13	NRST Pin Characteristics.....	84
4.3.14	SHRTIM Characteristics	85
4.3.15	Timer Characteristics.....	86
4.3.16	Watchdog Characteristics	88
4.3.17	I ² C Interface Characteristics	88
4.3.18	SPI/I ² S Interface Characteristics.....	90
4.3.19	xSPI Characteristics.....	94
4.3.20	FEMC Characteristics.....	96
4.3.21	USB_FS_Device Characteristics	110
4.3.22	Controller Area Network (CAN) Interface Characteristics	111
4.3.23	12 bit Analog-to-Digital Converter (ADC) Electrical Parameters.....	111
4.3.24	12-bit Digital-to-Analog Converter (DAC) Electrical Parameters	114
4.3.25	Comparator (COMP) Characteristics	116
4.3.26	Programmable Gain Amplifier (PGA) Characteristics	116
4.3.27	Voltage Reference Buffer (VREFBUF) Characteristics	118
4.3.28	Temperature Sensor (TS) Characteristics	118
5	PACKAGES	120
5.1	QFN32.....	120
5.2	UQFN48.....	121
5.3	LQFP48.....	122
5.4	LQFP64.....	123
5.5	LQFP80.....	124
5.6	LQFP100.....	125
5.7	LQFP128.....	126
6	MARKING INFORMATION.....	127
7	ORDERING INFORMATION.....	128
7.1	NAMING CONVENTION.....	128
7.2	ORDERING CODE	128
8	VERSION HISTORY	130
9	DISCLAIMER.....	131

List of Tables

Table 1-1 N32H474 Series Product Configuration.....	12
Table 2-1 Comparison Of Timer Functions.....	21
Table 3-1 Pin Description.....	46
Table 4-1 Voltage Characteristics	66
Table 4-2 Current Characteristics.....	66
Table 4-3 Temperature Characteristics	67
Table 4-4 General Operating Conditions.....	67
Table 4-5 Operating Conditions At Power-On And Power-Off.....	67
Table 4-6 Features Of Embedded Reset And Power Control Modules	68
Table 4-7 Internal Reference Voltage	69
Table 4-8 Maximum Current Consumption In Operating Mode Where Data Processing Code Is Run From Internal Flash	70
Table 4-9 Maximum Current Consumption In Sleep Mode, Code Running In Internal Flash Running.....	70
Table 4-10 Typical Current Consumption In Low Power Mode ⁽²⁾	71
Table 4-11 Typical Current Consumption In Low Power Mode ⁽²⁾	71
Table 4-12 Peripheral current consumption.....	72
Table 4-13 High-Speed External User Clock Features(Bypass Mode).....	74
Table 4-14 Features Of A Low-Speed External User Clock(Bypass Mode).....	74
Table 4-15 HSE 4-32MHz Oscillator Characteristics ^{(1) (2)}	76
Table 4-16 LSE Oscillator Characteristics (F _{LSE} = 32.768KHz) ⁽¹⁾	76
Table 4-17 HSI Oscillator Characteristics ^{(1) (2)}	77
Table 4-18 LSI Oscillator Characteristics ⁽¹⁾	78
Table 4-19 Wake Time In Low Power Mode.....	78
Table 4-20 PLL Features.....	78
Table 4-21 SHRTPLL Features	79
Table 4-22 Flash Memory Characteristics.....	79
Table 4-23 Flash Endurance And Data Retention Life.....	80
Table 4-24 Absolute Maximum ESD Value	80
Table 4-25 EMS Features.....	80
Table 4-26 Static Latch-Up	80
Table 4-27 I/O Static Characteristics.....	81
Table 4-28 IO Output Drive Capability Characteristics ⁽¹⁾	82
Table 4-29 Output Voltage Characteristics ⁽³⁾	82
Table 4-30 Input/Output AC Characteristics ⁽¹⁾	82
Table 4-31 NRST Pin Characteristics	84
Table 4-32 SHRTIM Characteristics ⁽¹⁾	85
Table 4-33 SHRTIM output response to fault protection ⁽¹⁾	85
Table 4-34 SHRTIM output response to external events 1 to 10 (Low-Latency mode ⁽¹⁾).....	86
Table 4-35 SHRTIM output response to external events 1 to 10 (Synchronous mode ⁽¹⁾).....	86
Table 4-36 SHRTIM synchronization input / output ⁽¹⁾	86

Table 4-37 ATIM1/2/3 Characteristics⁽¹⁾	87
Table 4-38 GTIM1/2/3/4/5/6/7 Characteristics⁽¹⁾	87
Table 4-39 GTIM8/9/10 Characteristics⁽¹⁾	87
Table 4-40 LPTIMER1/2 Characteristics	88
Table 4-41 IWDG Counting Maximum And Minimum Reset Time (LSI = 32 KHz)	88
Table 4-42 WWDG Counting Maximum And Minimum Reset Time (APB1 PCLK1 = 120 Mhz)	88
Table 4-43 I²C Interface Characteristics⁽¹⁾	89
Table 4-44 SPI Characteristics⁽¹⁾	91
Table 4-45 I²S Characteristics⁽¹⁾	93
Table 4-46 Characteristics Of XSPI In Single Data Rate (SDR) Mode	94
Table 4-47 Features of XSPI in Double Data Rate (DDR) Mode	95
Table 4-48 Features of XSPI in Double Data Rate (DDR) Mode	95
Table 4-49 Asynchronous Non-Multiplexed SRAM/PSRAM/NOR Read Timings⁽¹⁾⁽²⁾	97
Table 4-50 Asynchronous Non-Multiplexed SRAM/PSRAM/NOR Write Timings⁽¹⁾⁽²⁾	99
Table 4-51 Asynchronous Multiplexed PSRAM/NOR Write Timings⁽¹⁾⁽²⁾	100
Table 4-52 Asynchronous Multiplexed PSRAM/NOR Write Timings⁽¹⁾⁽²⁾	101
Table 4-53 Synchronous Non-Multiplexed PSRAM/NOR Read Timings⁽¹⁾⁽²⁾	103
Table 4-54 Synchronous Non-Multiplexed PSRAM Write Timings⁽¹⁾⁽²⁾	104
Table 4-55 Synchronous Multiplexed NOR/PSRAM Write Timings⁽¹⁾⁽²⁾	105
Table 4-56 Synchronous Multiplexed NOR/PSRAM Write Timings⁽¹⁾⁽²⁾	106
Table 4-57 Timing Characteristics of NAND Flash Read/Write Cycles⁽¹⁾	109
Table 4-58 USBFS Startup Time	110
Table 4-59 USBFS DC Characteristics	110
Table 4-60 Full Speed Of USB Electrical Characteristics	111
Table 4-61 ADC Characteristics	111
Table 4-62 ADC Sampling Time⁽¹⁾	112
Table 4-63 ADC Accuracy-Limited Test Conditions⁽¹⁾⁽²⁾⁽⁴⁾	112
Table 4-64 DAC 1MSPS Characteristics	114
Table 4-65 DAC 15MSPS Characteristics	115
Table 4-66 Comparator Characteristics	116
Table 4-67 PGA Characteristics in Single-Ended Mode⁽¹⁾	117
Table 4-68 PGA Characteristics in Differential Mode⁽¹⁾	117
Table 4-69 VREFBUF Characteristics⁽¹⁾	118
Table 4-70 Temperature Sensor Characteristics	118
Table 7-1 N32H474 Series Ordering Code	128

List of Figures

Figure 1-1 N32H474 Series Block Diagram	11
Figure 2-1 Memory Map	15
Figure 2-2 Clock Tree	18
Figure 3-1 QFN32 Pinout	39
Figure 3-1 UQFN48 Pinout	40
Figure 3-2 LQFP48 Pinout	41
Figure 3-3 LQFP64 Pinout	42
Figure 3-4 LQFP80 Pinout	43
Figure 3-5 LQFP100 Pinout	44
Figure 3-6 LQFP128 Pinout	45
Figure 4-1 Load Conditions Of Pins	63
Figure 4-2 Pin Input Voltage	64
Figure 4-3 Power Supply Scheme	65
Figure 4-4 Current Consumption Measurement Scheme	66
Figure 4-5 AC Timing Diagram Of An External High Speed Clock Source	75
Figure 4-6 AC Timing Diagram Of An External Low Speed Clock Source	75
Figure 4-7 Typical Application Using 8 MHz Crystal	76
Figure 4-8 Typical Application Of 32.768KHz Crystal	77
Figure 4-9 Definition Of Input/Output AC Characteristics	83
Figure 4-10 Transmission Delay	84
Figure 4-11 Recommended NRST Pin Protection	85
Figure 4-12 I ² C Bus AC Waveform And Measuring Circuit ⁽¹⁾	90
Figure 4-13 SPI Timing Diagram-Slave Mode And CPHA=0	91
Figure 4-14 SPI Timing Diagram-Slave Mode And CPHA=1 ⁽¹⁾	92
Figure 4-15 SPI Timing Diagram-Master Mode ⁽¹⁾	92
Figure 4-16 I ² S Slave Mode Timing Diagram (Philips Protocol) ⁽¹⁾	93
Figure 4-17 I ² S Master Mode Timing Diagram (Philips Protocol) ⁽¹⁾	94
Figure 4-18 Timing of XSPI in Single Data Rate (SDR) Mode	95
Figure 4-19 Timing of XSPI in Double Data Rate (DDR) Mode	95
Figure 4-20 Timing of XSPI in Double Data Rate (RXDS) Mode	96
Figure 4-21 Asynchronous Non-Multiplexed SRAM/PSRAM/NOR Read Waveforms	97
Figure 4-22 Asynchronous Non-Multiplexed SRAM/PSRAM/NOR Write Waveforms	99
Figure 4-23 Asynchronous Multiplexed PSRAM /NOR Read Waveforms	100
Figure 4-24 Asynchronous Multiplexed PSRAM/NOR Write Waveforms	101
Figure 4-25 Synchronous Non-Multiplexed PSRAM/NOR Read Waveforms	103
Figure 4-26 Synchronous Non-Multiplexed PSRAM Write Waveforms	104
Figure 4-27 Synchronous Multiplexed NOR/PSRAM Write Waveforms	105
Figure 4-28 Synchronous Multiplexed PSRAM Write Waveforms	106
Figure 4-29 NAND Controller Waveforms For Read Access	108
Figure 4-30 NAND Controller Waveforms For Write Access	108

Figure 4-31 NAND Controller Waveforms For Common Memory Read Access.....	109
Figure 4-32 NAND Controller Waveforms For Common Memory Write Access.....	109
Figure 4-33 USB Timing: Definition Of Rise And Fall Time Of Data Signal	110
Figure 4-34 ADC Precision Characteristics.....	113
Figure 4-35 Typical Connection Diagram Using ADC	113
Figure 5-1 QFN32 Package Dimensions.....	120
Figure 5-2 QFN32 Recommended Footprint ⁽¹⁾	120
Figure 5-1 UQFN48 Package Dimensions.....	121
Figure 5-2 UQFN48 Recommended Footprint ⁽¹⁾	121
Figure 5-3 LQFP48 Package Dimensions	122
Figure 5-4 LQFN48 Recommended Footprint ⁽¹⁾	122
Figure 5-5 LQFP64 Package Dimensions	123
Figure 5-6 LQFN64 Recommended Footprint ⁽¹⁾	123
Figure 5-7 LQFP80 Package Dimensions	124
Figure 5-8 LQFN80 Recommended Footprint ⁽¹⁾	124
Figure 5-9 LQFP100 Package Dimensions	125
Figure 5-10 LQFN100 Recommended Footprint ⁽¹⁾	125
Figure 5-11 LQFP128 Package Dimensions	126
Figure 5-12 LQFN128 Recommended Footprint ⁽¹⁾	126
Figure 6-1 Marking Information.....	127
Figure 7-1 N32H474 Series Part Number Information	128

1 Introduction

The N32H474 microcontrollers series features a high-performance 32-bit ARM Cortex™-M4F core with an integrated floating point operation unit (FPU) and digital signal processing (DSP). It operates at a frequency of up to 240MHz. It integrates up to 512-KB embedded flash, 192-KB SRAM (including 32-KB CCM SRAM), and 4-KB Backup SRAM. It also integrates 4x 12bit 4.7Msps ADCs, 8x 12bit DAC, 4x PGA, 7x COMP, USB FS Device, U(S)ART, I2C, SPI, CAN-FD, and other communication interfaces. It supports high-speed storage interfaces like FEMC, xSPI, as well as I2S audio interface. The microcontroller features super high-resolution timer, multiple advanced control timers, general timers, basic timers, low-power timers, and supports Cordic and FMAC. It also features a built-in hardware acceleration engine for cryptographic algorithms, supporting AES/TDES, SHA, SM3, SM4, MD5 algorithms, along with a TRNG true random number generator, and CRC16/32.

The N32H474 series products can operate reliably in the temperature range of -40 °C to +105 °C/125 °C and supply voltage from 1.8V to 3.6V. It offers multiple power modes to cater to low-power applications.

Figure 1-1 shows the bus block diagram of this series of products.

Figure 1-1 N32H474 Series Block Diagram

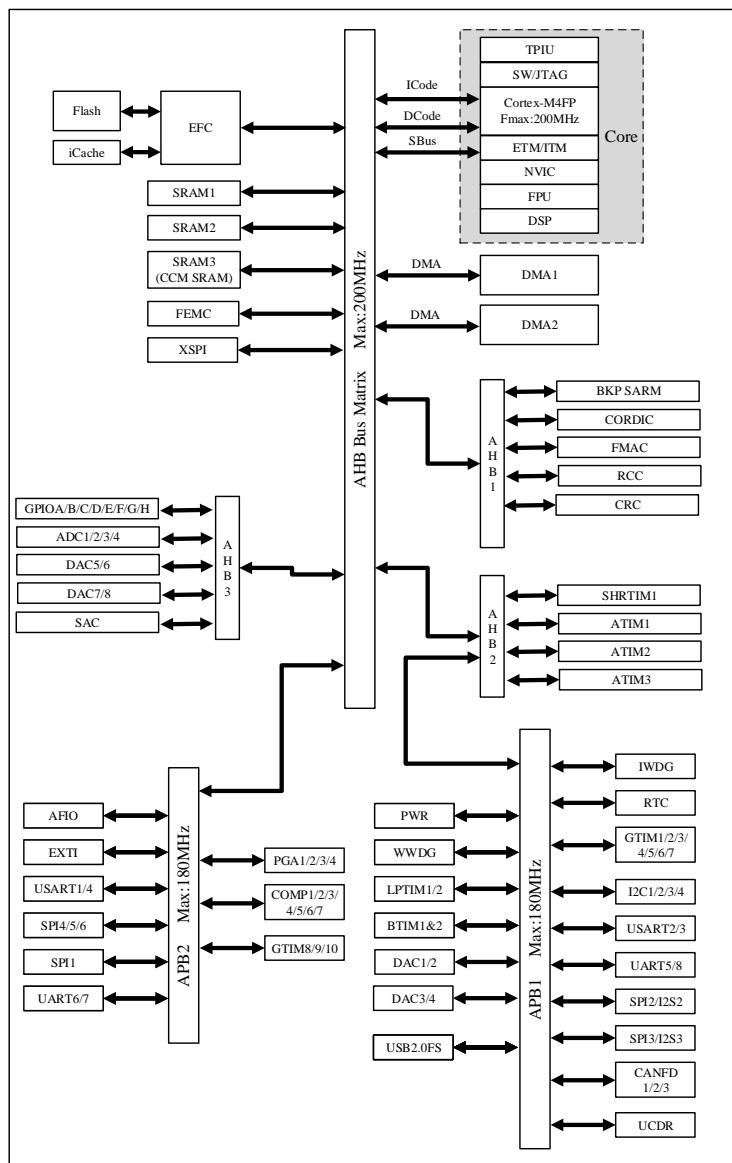

1.1 Product Configurations

Table 1-1 N32H474 Series Product Configuration

Device		N32H474KCQ7/8 N32H474KEQ7/8	N32H474CCU7/8 N32H474CEU7/8	N32H474CCL7 N32H474CEL7	N32H474RCL7/8 N32H474REL7/8	N32H474MCL7/8 N32H474MEL7/8	N32H474VCL7/8 N32H474VEL7/8 N32H474VEL7-W	N32H474QCL7/8 N32H474QEL7/8							
Operating Condition		1.8~3.6V/-40~105°C /125°C													
CPU Frequency		ARM Cortex-M4F @240MHz, 105°C, 300DMIPS ARM Cortex-M4F @200MHz, 125°C, 250DMIPS													
Flash Capacity (KB)		256	512	256	512	256	512	256	512	256	512	256	512	256	512
Total SRAM (KB)	General SRAM	112	160	112	160	112	160	112	160	112	160	112	160	112	160
	CCM SRAM ⁽¹⁾	32													
	Backup SRAM	4													
Times	SHRTIM	1*16bit ⁽²⁾						1*16bit							
	ATIM	3*16bit						3*16bit							
	GTIM	7*16bit						7*16bit				7*16bit			
		3*16bit						3*16bit				3*16bit			
	BTIM	2*32bit													
	LPTIM	2*16bit													
	SysTick timer	1													
	WWDG	1*14bit													
IWDG	1*12bit														
RTC	Yes														
Communication Interfaces	SPI/I2S	4/2			5/2						6/2				
	I ² C	4													
	USART	4													
	UART	4													
	USB FS Device	Yes													

	FDCAN	3						
Memory Expansion	XSPI	Yes ⁽³⁾			Yes			
	FEMC	No				Yes ⁽⁴⁾	Yes	
GPIO		26	42	38	52	66	86	107
WKUP Pins		2	3	3	4	4	5	5
DMA		2						
Number of channels		16Channel						
12bit ADC		4	4	4	4	4	4	4
Number of channels		13Channel	21Channel	20Channel	26Channel	38Channel	45Channel	51Channel
12bit DAC		8						
Number of channels		8 (4 External/Internal + 4 Internal)						
PGA		4						
COMP		7						
VREFBUF		No	Yes					
Algorithm Support		DES/3DES、AES、 SHA1/SHA224/SHA256、 SM3、 SM4、 MD5、 CRC16/CRC32						
TRNG		Yes						
Cordic		Yes						
FMAC		Yes						
Security Protection		Read-write protection (RDP/WRP), storage encryption, partition protection, secure boot						
Package		QFN32	UQFN48	LQFP48	LQFP64	LQFP80	LQFP100	LQFP128

Notes:

- (1) CCM SRAM is powered up as general SRAM by default, and users can configure it as CCM SRAM.
- (2) SHRTIM in the two packaging forms UQFN48 and LQFP48 only supports 4 timing units A~D, QFN32 only supports 2 timing units A/B
- (3) XSPI does not support 8-wire mode.
- (4) FMEC only supports address bus and data bus multiplexing.

2 Functional Overview

2.1 Processor Core

The N32H474 series integrates an ARM Cortex™-M4F processor. It features a floating-point processing unit (FPU), DSP and parallel computing instructions, providing excellent performance of 300 DMIPS. At the same time, its efficient signal processing capabilities combined with low power consumption, low cost, and ease of use advantages of the Cortex-M series processors. Make it suitable for applications that need a mix of control and signal processing capabilities in an easy-to-use manner.

The ARM Cortex™-M4F 32-bit reduced instruction set processor offers outstanding code efficiency.

2.2 Memories

The N32H474 series includes embedded encrypted Flash memory and embedded SRAM. The following diagram shows the memory address mapping.

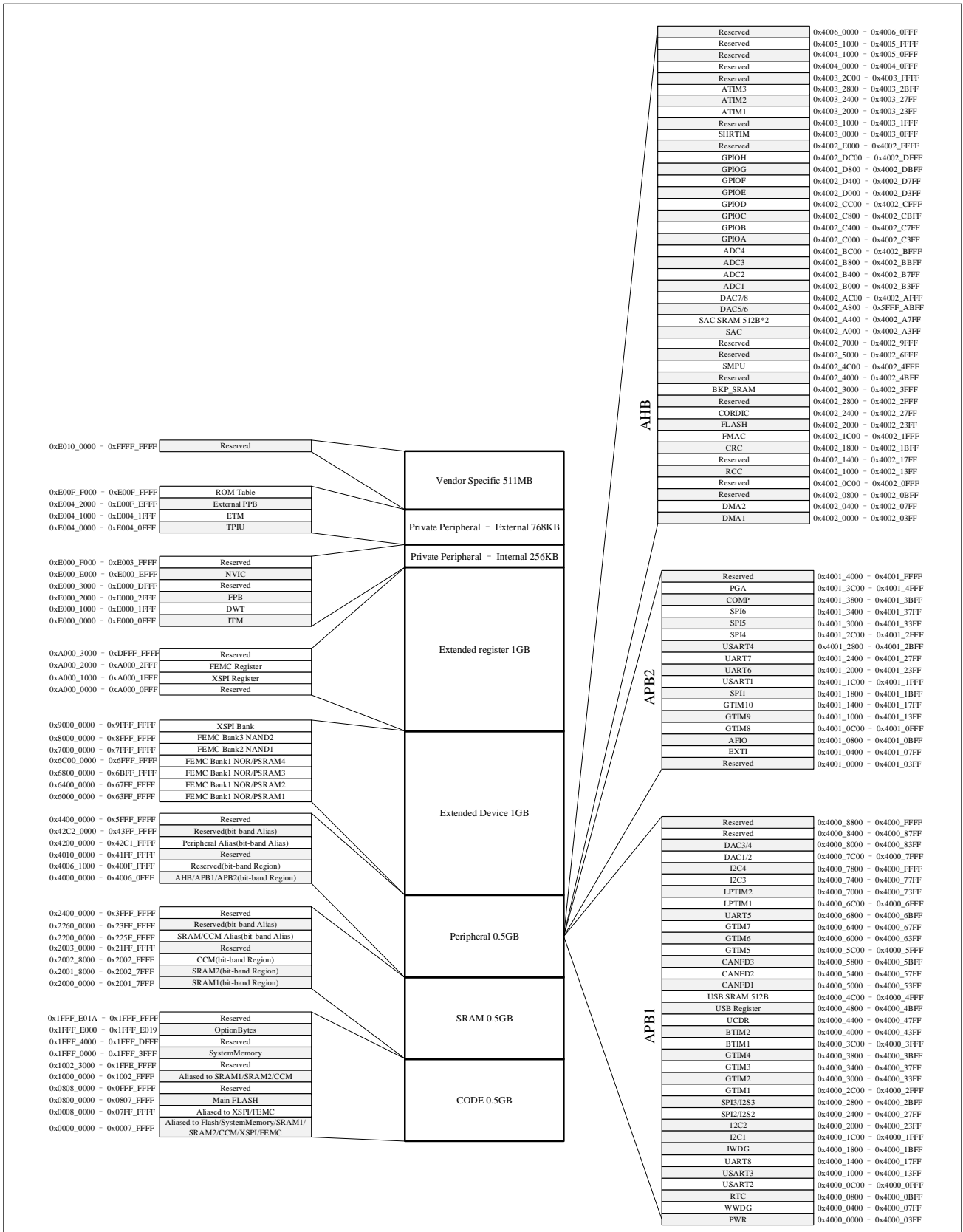
Figure 2-1 Memory Map

2.2.1 Embedded FLASH Memory

The integrated encrypted Flash memory size is from 256Kbytes to 512 Kbytes, utilized for storing programs and data. The page size is 8Kbytes, supporting page erasing, double-word writing, word reading, half-word reading, and byte reading operations.

It supports storage encryption protection, enabling automatic encryption during writing and automatic decryption during reading (including program execution operation).

User partition management is supported, allowing for a maximum of 3 user partitions, different users cannot access each other's data (only executable code can be accessed).

2.2.2 Embedded SRAM

The chip integrates a built-in SRAM of up to 192 Kbytes (including 160 Kbytes general SRAM and 32 Kbytes CCM SRAM) and a Backup SRAM of 4 Kbytes, as follows:

General SRAM has a maximum size of 160 Kbytes, supporting parity check.

CCM SRAM has a size of 32 Kbytes, powered up as general SRAM by default, can be configurable as CCM SRAM, supporting ECC.

BKP SRAM has a size of 4 Kbytes, can retain data in VBAT and Standby mode, supporting ECC.

2.2.3 Nested Vector Interrupt Controller (NVIC)

Main features:

- Up to 110 maskable interrupt channels (not including the 16 interrupt lines of Cortex-M4F)
- 16 programmable priority levels (four bits of interrupt priority used)
- Low-latency exception and interrupt handling
- Power management control
- Implementation of system control registers

The NVIC and the processor core interface are closely coupled, enabling low-latency interrupt processing and efficient processing of late arriving interrupts. All interrupts, including the core exceptions, are managed by the NVIC.

2.3 Extended Interrupt/Event Controller (EXTI)

The extended interrupt/event controller contains 30 edge detectors used for generating interrupt/event requests. Each interrupt line can be independently configured with its trigger event (rising edge, falling edge or both) and can be individually masked. The pending register holds interrupt requests for the status lines, and the interrupt requests can be cleared by writing '1' to the corresponding bit in the pending register.

2.4 Clock System

The device offers various clock options for users to choose from, including:

- High speed internal RC oscillator (HSI) at 8 MHz
- Low speed internal RC oscillator (LSI) at 32 KHz
- High speed external crystal oscillator (HSE) ranging from 4 MHz to 32 MHz.
- Low speed external crystal oscillator (LSE) at 32.768 KHz.

The system clock source can be selected from HSI, HSE, PLL, SHRTPLL. Upon reset, the internal MSI clock is set as the default system clock, user can choose the external HSE clock with fail monitoring capabilities. When an external clock failure is detected, it will be isolated, the system will automatically switch to HSI. If interrupts are enabled,

software can receive corresponding interrupts.

Multiple prescalers are used to configure the AHB frequency, high speed APB (APB2) and low speed APB (APB1) regions. The AHB has a maximum frequency of 240 MHz, APB2 has a maximum frequency of 180 MHz and APB1 has a maximum frequency of 180 MHz.

Refer to the clock tree diagram below.

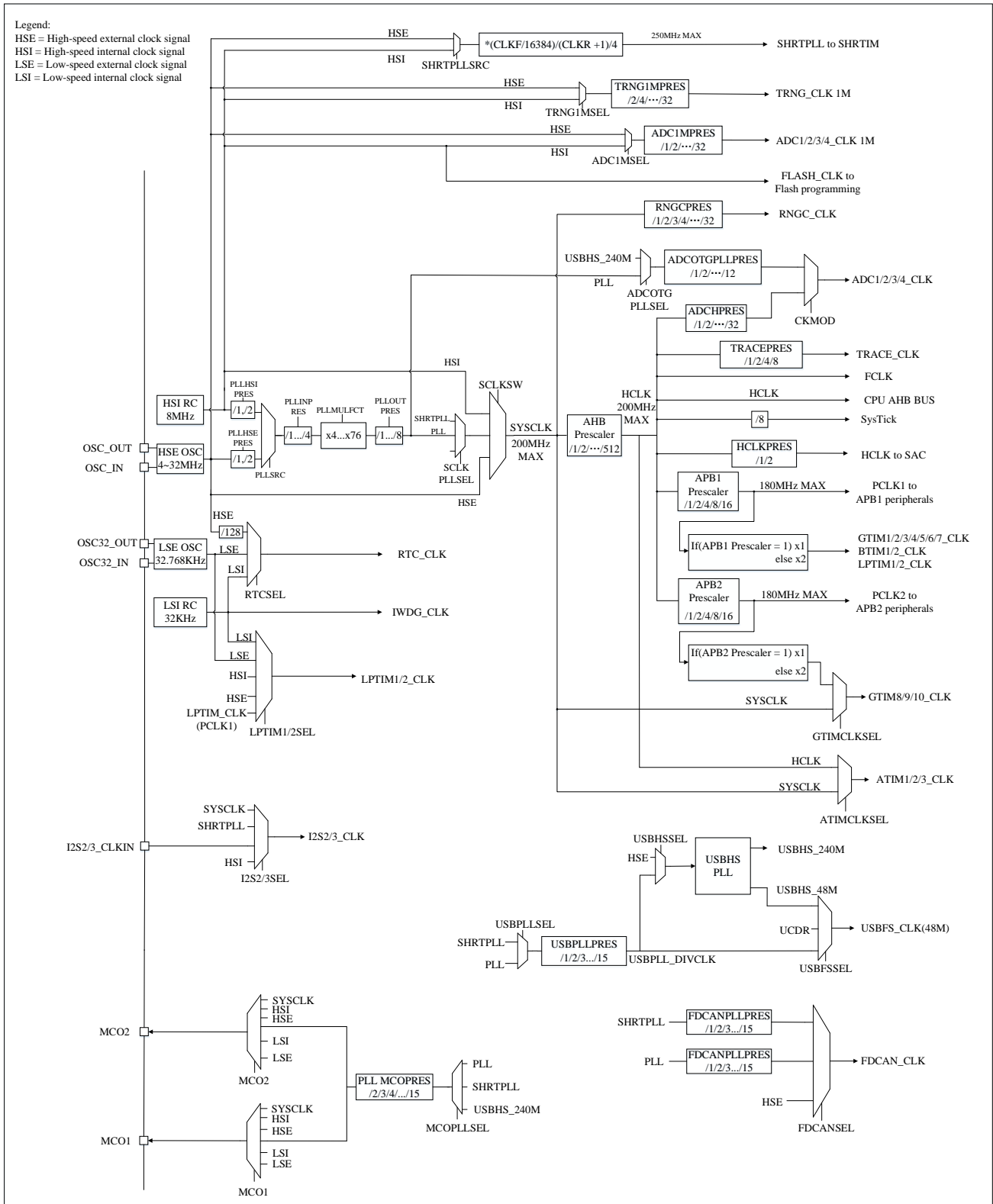
Figure 2-2 Clock Tree

2.5 Boot Modes

During startup, the BOOT mode after reset can be selected through the BOOT0 pin and option byte for BOOT configuration:

- Boot from Main Flash memory, including booting from the front bank (0x0800_0000) and rear bank (0x0804_0000) of Main Flash
- Boot from system memory
- Boot from embedded SRAM

The Bootloader is stored in the system memory and can program the flash memory through USART1 or USB interface.

Address remapping for physical address 0 can also be achieved by configuring `RCC_BOOTREMAP.REMAPSEL[2:0]`:

- Boot from xSPI external memory through remap
- Boot from FEMC external memory through remap

2.6 Power Supply Scheme

There are four external power supplies: VDD, VDDA, VREF, VBAT. Among them, VDD is the chip power supply, mainly for the power supply system and clock system; VDDA is the analog peripheral power supply, mainly for the analog peripherals; VREF provides a reference power supply for the analog peripherals to provide higher accuracy. VBAT is connected to the battery to provide power for the backup domain.

There are five power domains, powered by external power supplies for different power domains:

- V_{DD} domain: 1.8 to 3.6V, mainly powering for MR, most GPIOs, HSE, HSI, PLL, POR/PDR, BOR, PVD, and USB PHY
- V_{DDA} domain: 1.8 to 3.6V, mainly powering for ADC, DAC, COMP, PGA, VREFBUF, TS, etc.
- V_{DDBK} domain: 1.8 to 3.6V, mainly powering for WKUP pin, NRST, PC13/14/15, LSE, LSI, etc.
- V_{DDD} domain: 1.1 V or 0.9 V, mainly powering for CPU, AHB, APB, SRAM, FLASH, RCC, TRNG, and most peripherals
- V_{DDDBK} domain: 0.9 V or 0.8 V, mainly powering for PWR, Backup SRAM (4KB), RTC, LPTIM, WKUP pin, NRST, PC13/14/15, backup IOM, IWDG, and RCC_BDCTRL register.

2.7 Reset

POR and BOR circuits are integrated inside the device. This part of the circuit ensures that the system works stably when the power supply exceeds 1.8V. When V_{DD} falls below a set threshold (V_{POR/BOR}), the device goes into reset state without using an external reset circuit.

2.8 Programmable Voltage Detector

The device has a built-in programmable voltage detector (PVD), which monitors the power supply of V_{DD} and compares it with the threshold V_{PVD}. When V_{DD} is lower or higher than the threshold V_{PVD}, an interrupt will be generated. The interrupt handler can send a warning message, and the PVD function needs to be enabled through the program. See **Table 4-6** for values of V_{POR/PDR} and V_{PVD}.

2.9 Low Power Mode

The N32H474 series supports four low-power modes.

- SLEEP mode

In SLEEP mode, only the CPU is stopped, all peripherals remain operational and can wake up the CPU when an interrupt/event occurs.

- STOP0 mode

STOP0 mode is based on the Cortex-M4F deep sleep mode. Achieves the lowest power consumption, while retaining the content of SRAM and registers. Most clocks in the main power domain are stopped, such as PLL, HSE, HSI.

Wakeup: The device can be woken up from STOP0 mode by any of the 16 external EXTI signals (I/O related), PVD output, RTC timestamp, RTC alarm, etc.

- STANDBY Mode

In STANDBY mode, the device can achieve a lower current consumption. The internal voltage regulator is turned off, as well as PLL, HSI RC oscillator and HSE crystal oscillator. After entering STANDBY mode, most register contents will be lost, while the contents of backup registers will still be retained. The STANDBY circuitry continues to function.

Wakeup: External reset signal on NRST, IWDG reset, rising/falling edge on the WKUP pin, RTC alarm, RTC timestamp and LPTIM wake-up event can wake up the device from STANDBY mode.

- VBAT Mode

Whenever VDD power is lost, it will automatically enter VBAT mode. In VBAT mode, except for NRST, WKUP, PC13_TAMPER, PC14, and PC15, most I/O pins are in a high-impedance state.

Wakeup: VDD power up.

2.10 Direct Memory Access (DMA)

The DMA controller can access the following slaves: Flash, SRAM1, SRAM2, CCM SRAM3, FEMC, XSPI, CRC, FMAC, CORDIC, APB1, APB2, SHRTIM, ATIM, ADC, DAC.

The DMA controller is controlled by the CPU to perform fast data transfers from source to destination. After configuring, data can be transferred without any CPU intervention. This keeps the CPU resources free for other operations or saves overall system power consumption.

The device integrates two DMA controllers (DMA1, DMA2), each DMA supports eight channels. Each channel is dedicated to servicing memory access requests from one or more peripherals. Each controller has an arbiter for handling the priority between DMA channels.

The key features are as follows:

- 16 independently configurable channels (requests): Each DMA (DMA1, DMA2) supports 8 channels
- Support memory-to-memory, peripheral-to-memory and memory-to-peripheral transfers
- Each channel is connected to a dedicated hardware DMA request, a software trigger is also supported on each channel. This configuration is done by software.
- Each DMA channel has a dedicated software priority level (DMA_CHCFGx.PRIOLVL[1:0] bits, corresponding to 4 priority levels) that can be individually configured. Channels with the same priority level will further compare the hardware index (channel number) to determine the final priority (the channel with the lower index number has higher priority).
- Configurable source and destination transfer size (byte, half word, word). Source/destination addresses must be aligned on the data size.
- Support for circular buffer management
- 3 event flags (DMA half transfer, DMA transfer complete and DMA transfer error) and 1 global interrupt flag (set by logical OR of the 3 events) for each channel
- Access to Flash, Sram1, Sram2, CCM Sram3, FEMC, XSPI, CRC, FMAC, CORDIC, APB1, APB2, SHRTIM, ATIM, ADC, DAC
- Programmable number of data to be transferred: up to 65536
- Support burst transfers, burst length is configurable, can be set to 1/2/3/4/5/6/7/8 units.

2.11 Real Time Clock (RTC)

The RTC consists of continuously running counters integrated with a built-in calendar clock module that provides a perpetual calendar functionality, as well as alarm interrupts and periodic interrupt.

The key features are as follows:

- The Real-Time Clock (RTC) is an independent BCD (binary-coded decimal) timer/counter
- Software supports daylight saving time compensation
- Programmable periodic automatic wake-up timer.
- Two 32-bit registers containing hours, minutes, seconds, year, month, date, and week day
- One independent 32-bit register containing sub-seconds
- Two programmable alarms
- Two 32-bit registers containing programmed hours, minutes, seconds, year, month, date, and week day
- Two independent 32-bit registers containing programmed sub-seconds
- Digital precision calibration function
- Reference clock detection: a more precise second source clock (50 or 60 Hz) can be used to enhance the calendar precision
- Three configurable filtering and internal pull-up intrusion detection events
- Timestamp functionality
- 20 backup registers that can retain data in low-power mode
- Multiple interrupt/event wake-up sources, including alarm A, alarm B, wake-up timer, timestamp, and tamper event
- As long as the supply voltage remains in the operating range, the RTC never stops, regardless of the device status (Run mode, SLEEP mode, STOP0 mode and VBAT mode)
- The RTC provides various wake-up sources that can wake the MCU from all low-power modes (SLEEP mode, STOP0 mode, and STANDBY mode)

2.12 Timers and Watchdogs

The N32H474 series supports up to 1 super high-resolution timer, 3 advanced timers, 10 general timers, 2 basic timers, 2 low-power timers, as well as 1 independent watchdog timer, 1 window watchdog timer, and 1 SysTick timer.

The following table compares the functions of advanced control timer, general-purpose timer, basic timer and low-power timer:

Table 2-1 Comparison Of Timer Functions

Timer	Counter resolution	Counter type	Prescaler factor	Capture/compare channels	Complementary outputs
ATIM1~3	16	Up, down, up/down	Any integer between 1 and 65536	4	4
GTIM1~7	16	Up, down, up/down	Any integer between 1 and 65536	4	N
GTIM8~10	16	Up, down, up/down	Any integer between 1 and 65536	4	1

Timer	Counter resolution	Counter type	Prescaler factor	Capture/compare channels	Complementary outputs
BTIM1~2	32	Up	Any integer between 1 and 65536	0	N
LPTIM1~2	16	Up	1, 2, 4, 8, 16, 32, 64, 128	0	N

2.12.1 Super High-resolution Timer (SHRTIM)

The super high-resolution timer can generate up to 12 channels of highly precise digital signals, mainly used for driving power conversion systems such as switch-mode power supplies or lighting systems, but can also be used for applications with extremely high time resolution requirements.

This timer adopts a modular architecture that can generate independent waveforms or coupled waveforms. The waveform is determined by independent timing signals (using counters and comparator units) as well as various external events (such as analog or digital feedback and synchronous signals), thus enabling the generation of a wide range of control signals (PWM, phase shift, constant Ton, etc.), meeting the requirements of most conversion topologies.

For control and monitoring purposes, the timer also has timing measurement functions and is connected to built-in ADC and DAC converters. Additionally, the timer features a light-load management mode and can handle various fault mechanisms to achieve safe shut-down.

Main features:

- Multiple super high-resolution timing units
 - 125ps resolution, all outputs support full resolution, possibility to adjust duty cycle, frequency, and pulse width in triggered one-pulse mode
 - 6x 16-bit timing units (each timing unit contains 1 independent counter and 5 compare units, compare unit 5 dedicated to ADC triggering)
 - 12 channels of output can be controlled by any timing unit, with up to 32 set/reset sources for each channel
 - Modular structure can meet the requirements of multiple independent converters equipped with 1 or 2 switches, as well as the requirements of a few large multi-switch topologies
- Up to 10 external events can be used for any timing unit
 - Programmable polarity and edge effectiveness
 - 10 events with a fast asynchronous mode
 - 10 events with a programmable digital filters
 - Spurious events filtering with blanking and windowing modes
 - All 10 external events fully mapped to any GPIO or any analog comparator
- Multiple channels connect to built-in analog peripherals
 - 10 trigger signals for ADC converters, ADC trigger signals can be fully mapped to any compare unit
 - 3 trigger signals for DAC converters
 - 7 comparators for analog signal conditioning
- Rich protection mechanisms
 - 6 fault inputs can be combined and associated with any timing unit
 - 6 fault inputs can be fully mapped to any analog comparator
 - Programmable polarity and edge effectiveness, digital filters

- Resonant converters equipped with dedicated delay protection
- Multiple SHRTIM instances can be synchronized with external synchronization input/output
- Multi-functional output stage
 - Full resolution deadtime time insertion
 - Programmable output polarity
 - Chopping mode
- Burst mode controller, capable of handling light-load operations on multiple converters simultaneously, supporting 32-bit burst mode counting
- 8 interrupt vectors, each vector with up to 14 sources
- 7 DMA requests, with up to 14 sources, with a burst mode for multiple registers update

2.12.2 Basic Timer (BTIM1~2)

Basic timers contain a 32-bit auto-reload counter.

Main features:

- 32-bit auto-reload up-counting counter
- 16-bit programmable prescaler (The prescaler factor can be configured with any value between 1 and 65536)
- Event that generate the interrupt/DMA is as follows:
 - Update event

2.12.3 General-Purpose Timer (GTIM1~7)

The general-purpose timers (GTIM1/GTIM2/GTIM3/GTIM4/GTIM5/GTIM6/GTIM7) is mainly used in the following occasions: counting the input signal, measuring the pulse width of the input signal and generating the output waveform, etc.

Main features:

- 16-bit auto-reload counters (It can realize up-counting, down-counting, up/down counting)
- 16-bit programmable prescaler (The prescaler factor can be configured with any value between 1 and 65536)
- GTIMx supports up to 4 channels
- Channel's working modes: PWM output, output compare, one-pulse mode output, input capture
- The events that generate the interrupt/DMA are as follows:
 - Update event
 - Trigger event
 - Input capture
 - Output compare
- Timer can be controlled by external signal
- Timers can be linked together internally for timer synchronization or chaining
- Incremental (quadrature) encoder interface: used for tracking motion and resolving rotation direction and position
- Hall sensor interface: used to do three-phase motor control

2.12.4 General-Purpose Timer (GTIM8~10)

The general-purpose timers (GTIMx) is mainly used in the following occasions: counting the input signal, measuring the pulse width of the input signal and generating the output waveform, etc. The general-purpose timer features complementary output, dead-time insertion, and break functions. It is suitable for motor control.

Main features:

- 16-bit auto-reload counters (Supports up-counting, down-counting, up/down counting)
- 16-bit programmable prescaler (the prescaler factor can be configured with any value between 1 and 65536)
- Programmable repetition counter
- GTIMx supports up to 5 channels
- 4 capture/compare channels, operating modes include: PWM output, output compare, one-pulse mode output, input capture
- 1 break input signal supporting digital filtering, used to place the timer's output signal in a safe user-selectable configuration
- The events that generate the interrupt/DMA are as follows:
 - Update event
 - Trigger event
 - Input capture
 - Output compare
 - Break input
- Complementary outputs with programmable dead-time
 - For GTIMx, channel 1 support this feature
- Timer can be controlled by external signal
- Timers can be linked together internally for timer synchronization or chaining
- Incremental (quadrature) encoder interface: used for tracking motion and resolving rotation direction and position
- Hall sensor interface: used to do three-phase motor control
- Trigger input as an external clock or for per-cycle current management

2.12.5 Advanced Control Timer (ATIM1~3)

The advanced control timers (TIM1 and TIM8) is mainly used for the following purposes: counting the input signal, measuring the pulse width of the input signal and generating the output waveform, etc. Advanced timers have complementary output function with dead-time insertion and bracking functionality, making it suitable for motor control.

Main features:

- 16-bit auto-reload counters. (It can realize up-counting, down-counting, up/down counting)
- 16-bit programmable prescaler. (The prescaler factor can be configured with any value between 1 and 65536)
- Programmable Repetition Counter
- ATIMx supports up to 9 channels
- 4 capture/compare channels for:
 - PWM output

- Output compare
- One-pulse mode output
- Input capture
- 2 break input signals supporting digital filtering
- The events that generate the interrupt/DMA are as follows:
 - Update event
 - Trigger event
 - Input capture
 - Output compare
 - Break input
- Complementary outputs with programmable dead-time
 - For ATIMx, channel 1,2,3,4 support this feature
- Timer can be controlled by external signal
- Timers can be linked together internally for timer synchronization or chaining
- Incremental (quadrature) encoder interface: used for tracking motion and resolving rotation direction and position
- Hall sensor interface: used to do three-phase motor control
- Trigger input as an external clock or for per-cycle current management

2.12.6 Low Power Timer (LPTIM1~2)

The LPTIM is a 16-bit timer with multiple clock sources, it can keep running in all power modes. LPTIM can run without internal clock source as a “Pulse Counter”. Also, the LPTIM can wake up the system from low-power modes, to realize “Timeout functions” with extremely low power consumption.

Main features:

- 16-bit up counter
- 3-bit prescaler with 8 possible dividing factors (1,2,4,8,16,32,64,128)
- Multiple clock sources:
 - Internal clock source: LSE, LSI, HSI, HSE or APB1 clock
 - External clock source: External clock source through LPTIM Input1 (operating without LP oscillator, for Pulse Counter application)
- 16-bit auto-load register (LPTIM_ARR)
- 16-bit compare register (LPTIM_COMP)
- Continuous or one-shot mode counting mode
- Programmable software or hardware input trigger
- Programmable digital filter for glitch filtering
- Configurable output (PWM)
- Configurable IO polarity
- Encoder mode
- Pulse counting mode, support single pulse counting, double pulse counting (quadrature and non-quadrature)

2.12.7 SysTick Timer (SysTick)

This timer is dedicated to real-time operating systems and can also be used as a standard down-counter.

Main features:

- 24 bit down-counter
- Automatic reload function
- A maskable system interrupt is generated when the counter reaches 0
- Programmable clock source

2.12.8 Watchdog (WDG)

Built-in Independent Watchdog (IWDG) and Window Watchdog (WWDG) timers are used to detect issues caused by software errors. The watchdog timers are highly flexible, enhancing system security and the accuracy of timing control.

Independent watchdog (IWDG)

The Independent Watchdog (IWDG) is driven by the low-speed internal clock (LSI clock) running at 32 kHz. It can continue to operate in the event of a deadlock or MCU freeze. This provides a higher level of security, timing accuracy, and watchdog flexibility. It can resolve system failures caused by software faults through a reset. The IWDG is best suited for applications where the watchdog needs to run as a completely independent process outside the main application but with lower timing accuracy constraints.

When the power control register PWR_CTRL2.IWDGRSTEN is set to '1', a system reset occurs when the IWDG counter reaches 0 (if this is set to '0', the IWDG counts but does not trigger a reset).

Main features:

- Independent 12-bit down-counter
- The RC oscillator provides an independent clock source that can operate in SLEEP, STOP0, and STANDBY modes
- Support reset and low-power wake-up
- When the down-counter reaches 0x000, the system resets (if the watchdog is activated)

Window watchdog (WWDG)

The clock of the Window Watchdog (WWDG) is derived by dividing the APB1 clock frequency by 4096. It detects abnormal program execution through the configuration of the time window. Therefore, WWDG is suitable for precise timing and is commonly used to monitor software faults that cause the application program to deviate from its normal operation sequence due to external interference or unforeseen logical conditions. When the WWDG decrementing counter is refreshed before reaching the window register value or after the WWDG_CTRL.T6 bit becomes 0, a system reset occurs.

Main features:

- Programmable 14-bit independent down counter
- When the WWDG is enabled, a reset will occur under the following conditions:
 - The down-counter is less than 0x40
 - When the down counter value is greater than the value of the window register, reload will occur
- Early wake-up interrupt (EWI): triggered (if enabled and the watchdog activated) when the down-counter is equal to 0x40

2.13 I²C Bus Interface

The I²C (Inter-Integrated Circuit) bus is a widely used bus structure that consists of only two bidirectional lines,

namely the data line SDA and the clock line SCL. Through these two lines, all devices compatible with the I²C bus can directly communicate with each other via the I²C bus.

The I²C interface connects the microcontroller and the serial I²C bus, and can be used for communication between the MCU and external I²C devices. The I²C interface module implements the standard speed mode and fast mode of the I²C protocol, with CRC calculation and verification functions, supports SMBus (System Management Bus) and PMBus (Power Management Bus). It controls all I²C bus-specific sequencing, protocol, arbitration and timing. The I²C interface module also supports DMA mode to effectively reduce the burden on the CPU.

Main features:

- This module can be used as master device or slave device
- Support 7-bit/10-bit addressing and general call
- As an I²C master device, it can generate clock, start signal, and stop signal
- As an I²C slave device, it has programmable I²C address detection and stop bit detection functions
- Support Standard-mode (up to 100 kHz), Fast-mode (up to 400 kHz) and Fast-mode Plus (up to 1MHz)
- Supports interrupt vector, transfer complete interrupt, and error event interrupt
- Optional extend clock function
- Support DMA
- Generation or verification of configurable PEC (Packet error checking)
- Compatible with the PMBus and SMBus 2.0
- Support FIFO

2.14 Universal Synchronous/Asynchronous Transceiver (USART)

Universal Synchronous Asynchronous Receiver Transmitter (USART) is a full-duplex serial data exchange interface that supports synchronous or asynchronous communication. It can be flexibly configured to facilitate full-duplex data exchange with a variety of external devices.

The USART interface allows configurable transmission and reception baud rates, and also supports continuous communication through DMA. USART also supports multiprocessor communication, LIN mode, synchronous mode, single-wire half-duplex communication, smart card asynchronous protocol, IrDA SIR ENDEC function, as well as hardware flow control function.

Main features:

- Full duplex, asynchronous communication
- Single-wire half-duplex communications
- Programmable baud rate, up to 15 Mbit/s
- Configurable oversampling method by 16 or 8
- Programmable data word length (8 or 9 bits)
- Two internal FIFOs for transmit and receive data
- Configurable stop bits (1 or 2 stop bits)
- Support hardware-generated parity bit and parity bit checking
- Support hardware flow control: RTS, CTS
- Support transmission and reception via DMA
- Multiprocessor communications: If the address does not match, it enters mute mode. Wake-up from mute mode by idle line detection or address mark detection

- Support synchronous mode, allowing the user to control bidirectional synchronous serial communication in master mode
- Support asynchronous Smartcard protocol, compliant with ISO7816-3 standard
- Support IrDA (infrared data association) SIR ENDEC specifications, providing both normal and low power operation modes
- Support LIN mode
- Four error detection flags: Overflow error, Noise error, Frame error, Parity error
- Support multiple interrupt requests: Transmit data register empty, CTS flag, Transmission complete, Reception complete, Data overflow, Bus idle, Parity error, LIN mode break frame detection, and noise flags/overflow errors/frame errors in multi-buffer communications

Mode configuration:

USART modes	USART1	USART2	USART3	USART4	UART5	UART6	UART7	UART8
Asynchronous mode	Y	Y	Y	Y	Y	Y	Y	Y
Multiprocessor communication	Y	Y	Y	Y	Y	Y	Y	Y
LIN	Y	Y	Y	Y	Y	Y	Y	Y
Synchronous mode	Y	Y	Y	Y	N	N	N	N
Half duplex (Single wire mode)	Y	Y	Y	Y	Y	Y	Y	Y
Smartcard mode	Y	Y	Y	Y	N	N	N	N
IrDA	Y	Y	Y	Y	Y	Y	Y	Y
DMA	Y	Y	Y	Y	Y	Y	Y	Y
Hardware flow control	Y	Y	Y	Y	Y	Y	Y	Y

Note: Y = supported; N = not supported.

2.15 Serial Peripheral Interface/inter-integrated sound interfaces (SPI/I²S)

The SPI protocol supports half-duplex, full-duplex and synchronous, serial communication with external devices. The interface can be configured as master or slave and can operate in multi-slave or multi-master configurations. The device configured as master provides communication clock (SCK) to the slave device. It can be used for a variety of purposes, including simplex synchronous transfers on two lines with bidirectional data line, and also support hardware CRC check.

I²S is also a synchronous serial interface communication protocol. It supports four audio standards, including the Philips I²S standard, MSB and LSB alignment standards, and PCM standards. In half-duplex communication, it can operate in two modes: master and slave. When operating as a master device, it can provide clock signals to external slave devices via the interface.

The SPI main features are:

- Full-duplex and simplex synchronous transmission
- Support master, slave and multi-master mode
- 8- or 16-bit transmission frame format selection
- Programmable data order
- Hardware or software management of chip select signal
- Programmable clock polarity and phase
- Support hardware CRC calculation and check
- Support DMA transfer

- 8 bytes transmit/receive FIFO

The I²S main features are:

- Full-duplex and half-duplex synchronous transmission
- Support master, slave mode
- Supported I²S protocols:
 - I²S Philips standard
 - MSB-Justified standard (Left-Justified)
 - LSB-Justified standard (Right-Justified)
 - PCM standard (with short and long frame synchronization)
- Configurable audio sampling frequency, ranging from 8KHz to 192KHz
- Programmable clock polarity (steady state)
- Data order is always MSB first
- Support DMA transfer
- Support multiple clock sources

2.16 Expanded Serial Peripheral Interface(xSPI)

xSPI is an interface used for communication with single/dual/quad/octal line SPI peripherals. It can operate in two modes: indirect and memory-mapped mode.

It supports indirect mode: all operations are performed using xSPI registers; memory-mapped mode: the external Flash is memory mapped and is seen by the system as if it were an internal memory.

Main features:

- Configurable for 1/2/4/8-bit data
- Support Single SPI/Normal SPI、 DUAL SPI、 QUAD SPI、 Dual-QUAD、 OCTAL SPI modes
- Support Motorola SPI:
 - Standard/Dual/Quad/Octal SPI
- Support SDR and DDR modes
- Support DDR transfer data mask
- Support clock stretching
- In indirect mode and memory-mapped mode, frame format and operation codes can be software configured
- Integrated FIFO for reception and transmission
- 8/16/32-bit data accesses allowed
- 16 words TX FIFO and 16 words RX FIFO
- Support DMA transfer
- XIP mode supports SPI read and write, and supports serial NOR FLASH
 - Support continuous transfer mode
 - Support data prefetch
- Support automatic decryption of executed code, meaning that the xSPI peripheral stores encrypted code, reads the encrypted code during execution, and decrypts it to plaintext for CPU execution, without affecting the access speed to the peripheral storage. The decryption can be software configurable to enable/disable, and the root key

is stored in the NVR area, inaccessible to the user

- Support serial NAND FLASH and PSRAM
- When xSPI accesses external memory for read and write, after xSPI initialization, there is no need for additional configuration of xSPI between writing to and reading from external storage, allowing direct memory access (via SRAM address) for reading and writing to external memory
- Support 2 external chip select output controls in master mode; Support 1 chip select input in slave mode. All IOs multiplexed as chip select outputs in master mode can be multiplexed as chip select inputs in slave mode
- Support multi-master arbitration function

2.17 Controller area network (FDCAN)

The N32H474 provides 3 FDCAN controllers that comply with ISO 11898-1:2015 standard, supporting CAN 2.0A/B and CAN FD protocols, and are compatible with Bosch non-ISO standard protocols.

All FDCAN modules share a message RAM area for receiving message filters, receiving FIFOs, receive buffers, transmit buffers, and transmit event FIFOs. The message RAM is located in the MCU's internal SRAM, with a configurable starting address and a maximum allocation of 4480 words (32-bit).

Main features:

- Complies with ISO 11898-1:2015 and ISO 11898-4 standards
- Support CANFD, data size up to 64 byte
- Support CAN error log record
- Support AUTOSRA standard
- Support SAE J1939 standard
- Enhanced receive filter
- Two configurable receive FIFOs
- Separate signal indication when receiving high-priority messages
- Up to 64 dedicated receive buffers
- Up to 32 dedicated transmit buffers
- Configurable transmit FIFO or queue
- Configurable transmit event FIFO
- Support configurable message RAM shared by all FDCAN controllers
- Programmable loopback test mode
- Maskable module interrupt
- Two clock domains: CAN core clock and APB bus clock
- Support power-down mode

2.18 Flexible External Memory Controller (FEMC)

The Flexible External Memory Controller (FEMC) is used to access various external memories, enabling easy expansion of different types of high-capacity static memories according to application needs. It can simultaneously expand multiple types of static memories without increasing external interfaces. All external memories share the address, data, and control signals output by the FEMC controller, and FEMC distinguishes different external devices through a unique chip select signal.

Main features:

- Support the following devices:
 - SRAM
 - PSRAM
 - ROM
 - NOR Flash
 - NAND Flash (SLC)
 - LCD (8080/6800)
- Support two NAND flash blocks, hardware 1-bit ECC can detect up to 8K bytes of data
- Burst mode support for faster access to synchronous devices, such as NOR flash and PSRAM
- 8/16-bit data bus width
- Independent chip select control for each memory bank
- Support various different devices through timing programming
- Based on the data width of the external memory, it automatically converts 32-bit AHB access requests into consecutive 16-bit or 8-bit accesses, enabling communication with external 16-bit or 8-bit memory devices. It converts 32-bit AHB access requests into consecutive 16-bit or 8-bit accesses for accessing external 16-bit or 8-bit devices
- Write enable and byte lane select outputs for use with PSRAM and SRAM devices

2.19 Universal Serial Bus Full-Speed Device Interface (USB_FS)

The Universal Serial Bus Full-Speed Device Interface (USB_FS_Device) module is a peripheral that complies with the USB 2.0 Full-Speed protocol. It includes the physical layer USB PHY and does not require an additional PHY chip. The USB_FS_Device supports four types of transfers defined in the USB 2.0 protocol: **control transfer**, **bulk transfer**, **interrupt transfer**, and **isochronous transfer**.

Main features:

- Comply with the technical specifications of USB2.0 full-speed equipment
- Configurable up to 8 USB endpoints
- Each endpoint supports the four types of transfer defined in the USB 2.0 protocol:
 - Control transfer
 - Bulk transfer
 - Interrupt transfer
 - Synchronous transfer
- Double buffer mechanism for bulk/isochronous endpoints
- Cyclic redundancy check (CRC) generation/checking, Non-return-to-zero Inverted (NRZI) encoding/decoding and bit-stuffing
- Support USB Suspend/Resume operation
- Frame locked clock pulse generation

2.20 Filter Math Accelerator (FMAC)

The FMAC performs arithmetic operations on vectors. It comprises a multiplier/accumulator (MAC) unit, together with address generation logic that allows it to index vector elements held in local memory. The unit includes support for circular buffers on input and output, that allows digital filters to be implemented. Both finite and infinite impulse response filters can be done.

The unit allows frequent or lengthy filtering operations to be offloaded from the CPU, freeing up the processor for other tasks. In many cases it can accelerate such calculations compared to a software implementation, resulting in a speed-up of time critical tasks.

Main features:

- 16 x 16-bit multiplier
- 24 + 2-bit accumulator with addition and subtraction
- 16-bit input and output data
- 256 x 16-bit local memory
- Up to three areas can be defined in memory for data buffers (two input, one output), defined by programmable base address pointers and associated size registers
- Input and output buffers can be circular
- Filter functions: FIR, IIR (direct form 1)
- Vector functions: dot product, convolution, correlation
- DMA read and write data channels

2.21 CORDIC Co-processor (CORDIC)

The CORDIC co-processor provides hardware acceleration of certain mathematical functions, notably trigonometric, commonly used in motor control, metering, signal processing and many other applications.

Main features:

- Support rotation and vector calculation modes
- Support circular and hyperbolic coordinate systems
- Once the calculation starts, any operation to read the result register will insert the bus into a waiting state until the calculation is completed. Therefore, the calculation result can be read out when it is completed without the need for polling or interrupts.
- Support 10 functions: sine, cosine, sinh, cosh, atan, atan2, atanh, modulus, square root, natural logarithm
- Support fixed-point and floating-point input/output modes
- Support interrupt, polling, and DMA request read/write modes
- Programmable precision

2.22 General-Purpose Input/Output Interface (GPIO)

Up to 107 GPIOs, which can be divided into eight groups (GPIOA/GPIOB/GPIOC/GPIOD/GPIOE/GPIOF/GPIOG/GPIOH). GPIO ports share pins with other multiplexed peripherals, allowing users to configure them flexibly according to requirements. Each GPIO pin can be configured by software as an output (push pull or open drain), input (with or without pull-up or pull-down), or alternate peripheral function port. All GPIO pins have high current passing capability except ports with analog input capability.

Main features:

- Each bit of the GPIO port can be configured separately by the software into multiple modes:
 - Input floating
 - Input pull up
 - Input pull down
 - Analog function
 - Open-drain output, pull-up and pull-down configurable
 - Push-pull output, pull-up and pull-down configurable
 - Push-pull alternate function, pull-up and pull-down configurable
 - Open-drain alternate function, pull-up and pull-down configurable
- Independent bit set or set functions
- All I/O support external interrupts
- All I/O support low-power mode wake-up, with configurable rising or falling edge:
 - 16 EXTI lines can be used for STOP0 mode wake-up, and all I/O can be multiplexed as EXTI
 - PA0/PA2/PC5/PC13/PE6 can be used to wake-up from STANDBY mode
- Support software configure alternate function selection
- Support GPIO lock mechanism, can only be cleared by reset once locked

Each I/O port bit can be programmed arbitrarily, but the I/O port register must be accessed in 32-bit words (16-bit half-word or 8-bit byte access is not allowed).

2.23 Analog/Digital Converter (ADC)

12 bit ADC consists of a 12-bit successive approximation high-speed analog-to-digital converter. There are four ADCs, ADC1/ADC2, ADC3/ADC4 that can be combined into dual ADCs mode; ADC1/ADC2/ADC3 can be combined into triple ADCs mode. Each ADC has up to 19 multiplexed channels. A/D conversion of the various channels can be performed in single, continuous, scan or discontinuous mode. The result of the ADC is stored in a left-aligned or right-aligned 16-bit data register. The analog watchdog1/2/3 feature allow the application to detect if the input voltage goes outside the user-defined high or low thresholds, and the frequency of ADC input clock is up to 80 MHz.

Main features:

- Support 4 ADCs, support single-ended or differential inputs
 - ADC1 is connected to 16 external channels and to 3 internal channels
 - ADC2 is connected to 18 external channels and to 1 internal channels
 - ADC3 is connected to 19 external channels
 - ADC4 is connected to 19 external channels
- Support 12/10/8/6-bits resolution configurable
 - The maximum sampling rate at 12bit resolution is 4.7 MSPS
 - The maximum sampling rate at 10bit resolution is 6 MSPS
 - The maximum sampling rate at 8bit resolution is 7.2 MSPS

- The maximum sampling rate at 6bit resolution is 9 MSPS
- ADC clock source is divided into working clock source, sampling clock source and timing clock source
 - AHB_CLK can be configured as the working clock source, up to 240 MHz
 - PLL can be configured as a sampling clock source, up to 80 MHz, support 1, 2, 3, 4, 6, 8, 10, 12 frequency division
 - The AHB_CLK can be configured as the sampling clock source, up to 80 MHz, and supports frequency 1, 2, 3, 4, 6, 8, 10, 12, 16, 32
 - The timing clock is used for internal timing functions and the frequency must be configured to 1MHz
- Supports EXTI/TIMER trigger ADC sampling
- The sampling time interval for all channels can be programmed independently
- 3 analog watchdogs per ADC
- When the ADC is ready, sampling is completed, conversion is finished, or an analog watchdog 1/2/3 event occurs, an interrupt can be triggered
- Support 4 conversion modes:
 - Single conversion
 - Continuous conversion
 - Discontinuous mode
 - Scan mode
- Support self-calibration
- Data alignment with in-built data coherency
- Start-of-conversion can be initiated:
 - By software for both regular and injected conversions
 - By hardware triggers with configurable polarity (internal timers events or GPIO input events) for both regular and injected conversions
- Oversampling
 - 16-bit data register
 - Adjustable oversampling ratio, x2, x4, x8, x16, x32, x64, x128, x256
 - Programmable data right shift up to 8 bits
- Data preconditioning
 - Support offset compensation
 - Support gain compensation
- Multi-ADC mode
 - Dual ADC mode: ADC1 and ADC2 combined, ADC3 and ADC4 combined
 - Triple ADC mode: ADC1, ADC2, and ADC3 combined
- ADC power supply requirements: 1.8V to 3.6V
- ADC input range: $V_{REF-} \leq V_{IN} \leq V_{REF+}$

2.24 Analog Comparator (COMP)

The COMP module is used to compare the magnitudes of two input analog voltages and output high or low levels based on the comparison result. When the voltage at the "INP" input is higher than the voltage at the "INM" input, the comparator outputs a high level; when the voltage at the "INP" input is lower than the voltage at the "INM" input, the comparator outputs a low level.

Main features:

- 7x independent comparators
- Built-in three 64-level programmable comparison voltage reference sources VREF1, VREF2, VREF3
- Supports filtering clock, filtering reset
- Output polarity can be configured as high or low
- Supports 8 programmable hysteresis levels
- The comparison result can be output to the I/O port or trigger the timer for capturing events, OCREF_CLR events, brake events, and generating interrupts.
- The input channels can be reselected to I/O ports, VREF1, VREF2, VREF3, the general 12-bit DAC, and the channel output of the internal PGA.
- Can be configured as read-only or read-write, and requires a reset to unlock when locked.
- Supports blanking, and the blanking source that generates blanking can be configured.
- Wake up the system from Sleep mode by generating interrupts.
- Filter window size can be configured.
- Filter threshold size can be configured.
- Sampling frequency for filtering can be configured.

2.25 Digital/Analog Converter (DAC)

DAC is Digital-to-Analog Converter, which primarily involves digital input and voltage output. The DAC can be configured in 8-bit or 12-bit mode and may be used in conjunction with the DMA controller. In 12-bit mode, the data can be left or right-aligned. In 8-bit mode, the data can be right-aligned. Each DAC has its own converter and can perform conversions independently. In dual DAC mode, conversions can be done independently or simultaneously when both DACs are grouped (DAC1 & DAC2) together for synchronous update operations.

When the DAC output is internally connected to peripherals on the chip, the DACx_OUT pin can be used as a general-purpose input/output (GPIO). The DAC output buffer can be selectively enabled to obtain a high-drive output current.

Main features:

- Supports 8 DACs, each DAC has its own converter
- An output channel for a built-in Buffer
- Supports 8-bit or 12-bit output, with left or right data aligned in 12-bit mode
- Dual DAC channel for independent or synchronous conversions
- Each DAC supports DMA functionality including DMA underrun error detection
- DMA double data mode can save bus bandwidth
- Generates Noise-wave, Triangular-wave and Sawtooth waveforms.
- DAC output supports connection to on-chip peripherals.

- Buffer offset calibration.
- Input voltage reference from V_{REF+} and internal VREFBUG.
- External triggers for conversion

2.26 Programmable Gain Amplifier (PGA)

The PGA (ProgrammableGain Amplifier) is used to amplify input voltages. The chip has a total of 4 differential PGAs, each of which can be split into 2 single-ended PGAs for independent use. The output of the PGA can be elected to connect internally to the ADC or the input channel of COMP.

Main features:

- Supports rail-to-rail input
- Supports a 12-bit DAC as input for the PGA
- Programmable single-ended mode gain settings of 1X, 2X, 4X, 8X, 12X, 16X, 24X, and 32X
- Programmable gain settings of 2X, 4X, 8X, 16X, 24X, 32X, 48X, and 64X
- Supports automatic switching of input pins for PGA1 and PGA2 via ATIM1_CC6 and PGA2, and for PGA3 and PGA4 via ATIM2_CC6.
- Supports independent write protection

2.27 Voltage Reference Buffer (VREFBUF)

The chip is equipped with a voltage reference buffer that can be used as a voltage reference for the ADC, 12-bit DAC, and internal 6-bit DAC of the COMP. It can also serve as a voltage reference for external components through the VREF+ pin.

2.28 Cyclic Redundancy Check Calculation Unit (CRC)

The module integrates CRC32 and CRC16. The cyclic redundancy check (CRC) calculation unit is based on a fixed generation polynomial to obtain arbitrary CRC calculation results. In many applications, CRC-based techniques are used to verify data transfer or storage consistency. Within the scope of the EN/IEC 60335-1 standard, it provides a means of detecting flash memory errors. The CRC unit can be used to calculate signatures of software in real time and compare them with signatures generated during connection, storing it in a specified memory space.

Main features of CRC32:

- CRC32 ($X^{32} + X^{26} + X^{23} + X^{22} + X^{16} + X^{12} + X^{11} + X^{10} + X^8 + X^7 + X^5 + X^4 + X^2 + X + 1$)
- 32-bit data to be checked and 32-bit output checksum
- CRC32 calculation time: 1 AHB clock cycles (HCLK)
- General-purpose 8-bit register
- Programmable CRC initial value

Main features of CRC16:

- CRC16 ($X^{16} + X^{15} + X^2 + 1$)
- 8-bit data to be checked and 16-bit output checksum
- CRC16 calculation time: 1 AHB clock cycles (HCLK)
- Configurable check initial value, and configurable endianness of the data to be checked

- Support 8-bit LRC checksum value generation
- Programmable CRC initial value

2.29 Secure Algorithm Co-processor (SAC)

The device features a secure algorithm acceleration engine, it supports various international algorithms and hash algorithm, which can greatly improve the speed of encryption and decryption compared with pure software algorithm.

The hardware supports the following algorithms:

- DES Symmetric Algorithms
 - DES and 3DES encryption and decryption operations are supported
 - TDES supports 2KEY and 3KEY mode
 - Support CBC and ECB mode
- AES Symmetric Algorithm
 - Support 128bits, 192bits, or 256bits key length
 - Support CBC, ECB, and CTR mode
- SM4 Symmetric Algorithm
 - Support CBC, ECB mode
- SHA Hash Algorithm
 - Supports SHA1, SHA244, SHA256
- MD5 digest algorithm
- Support SM3 Hash Algorithm
- Random Number Generation

Note: The SAC module operating clock is up to 180MHz, so the HCLK frequency should not exceed 180MHz to avoid abnormal operation of the SAC module.

2.30 Unique Device Serial Number (UID)

The N32H474 series products have two built-in unique device serial numbers of different lengths, which are 96-bit unique device ID (UID) and 128-bit unique customer ID (UCID). These two device serial numbers are stored in the system configuration block of Flash memory. The information they contain is written at the time of delivery and is guaranteed to be unique to any of the N32H474 series microcontrollers under any circumstances and can be read by user applications or external devices through the CPU or JTAG/SWD interface and cannot be modified.

The 96-bit UID is usually used as a serial number or password. When writing Flash memory, this unique identifier is combined with software encryption and decryption algorithm to further improve the security of code in Flash memory. It can also be used to activate Secure Bootloader with security functions.

The UCID is 128-bit, which complies with the definition of Nations technology chip serial number. It contains the information related to chip production and version.

2.31 Serial Single-Wire JTAG Debug Port (SWJ-DP)

The device has an embedded ARM SWJ-DP interface, which is a combination of JTAG and serial single-wire

debugging interface, can achieve serial single-line debugging interface or JTAG interface connection. The JTMS and JTCK signals of JTAG share pins with SWDIO and SWCLK respectively, and a special signal sequence on the JTMS pin is used to switch between JTAG-DP and SW-DP.

3 Pinouts and Pin Description

3.1 Pinouts

3.1.1 QFN32

Figure 3-1 QFN32 Pinout

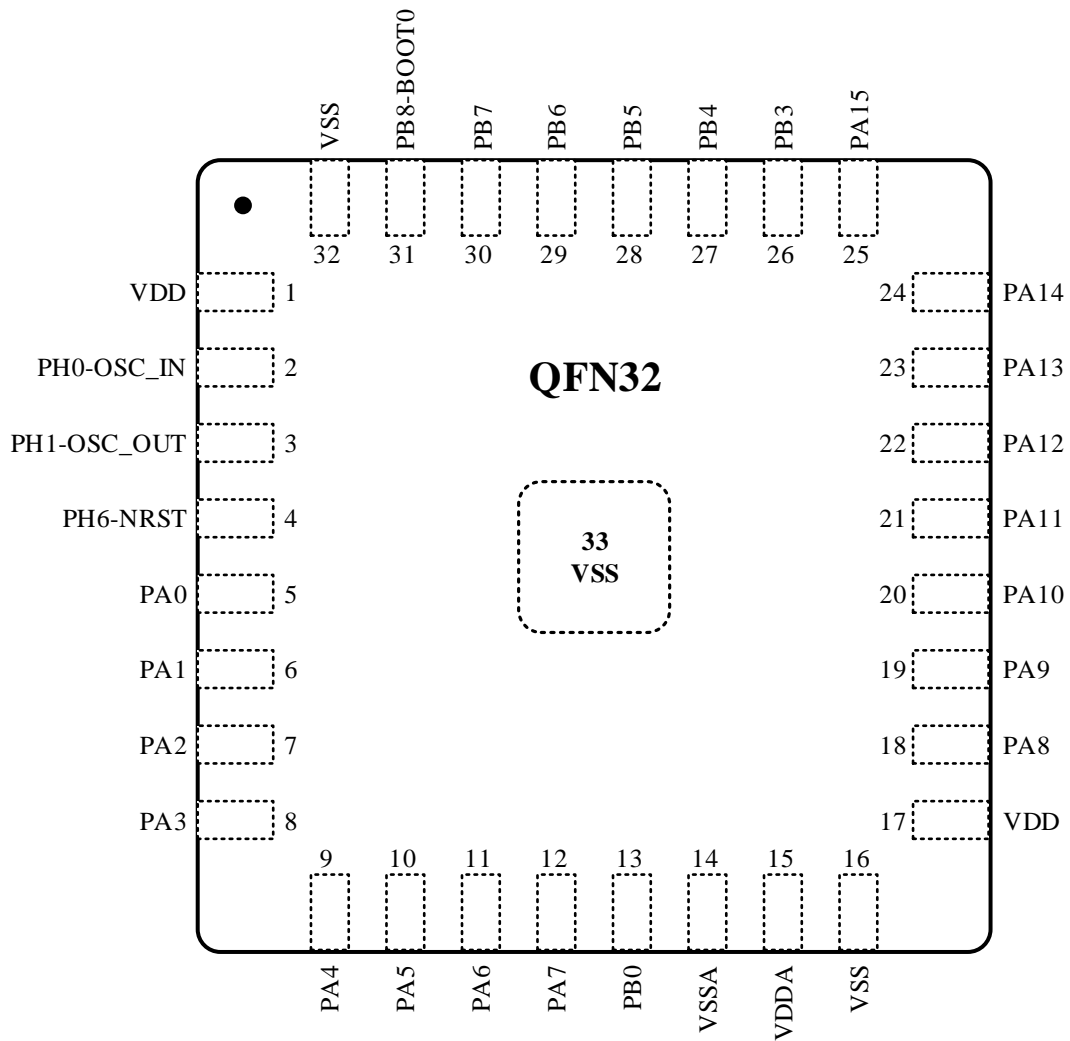

3.1.2 UQFN48

Figure 3-2 UQFN48 Pinout

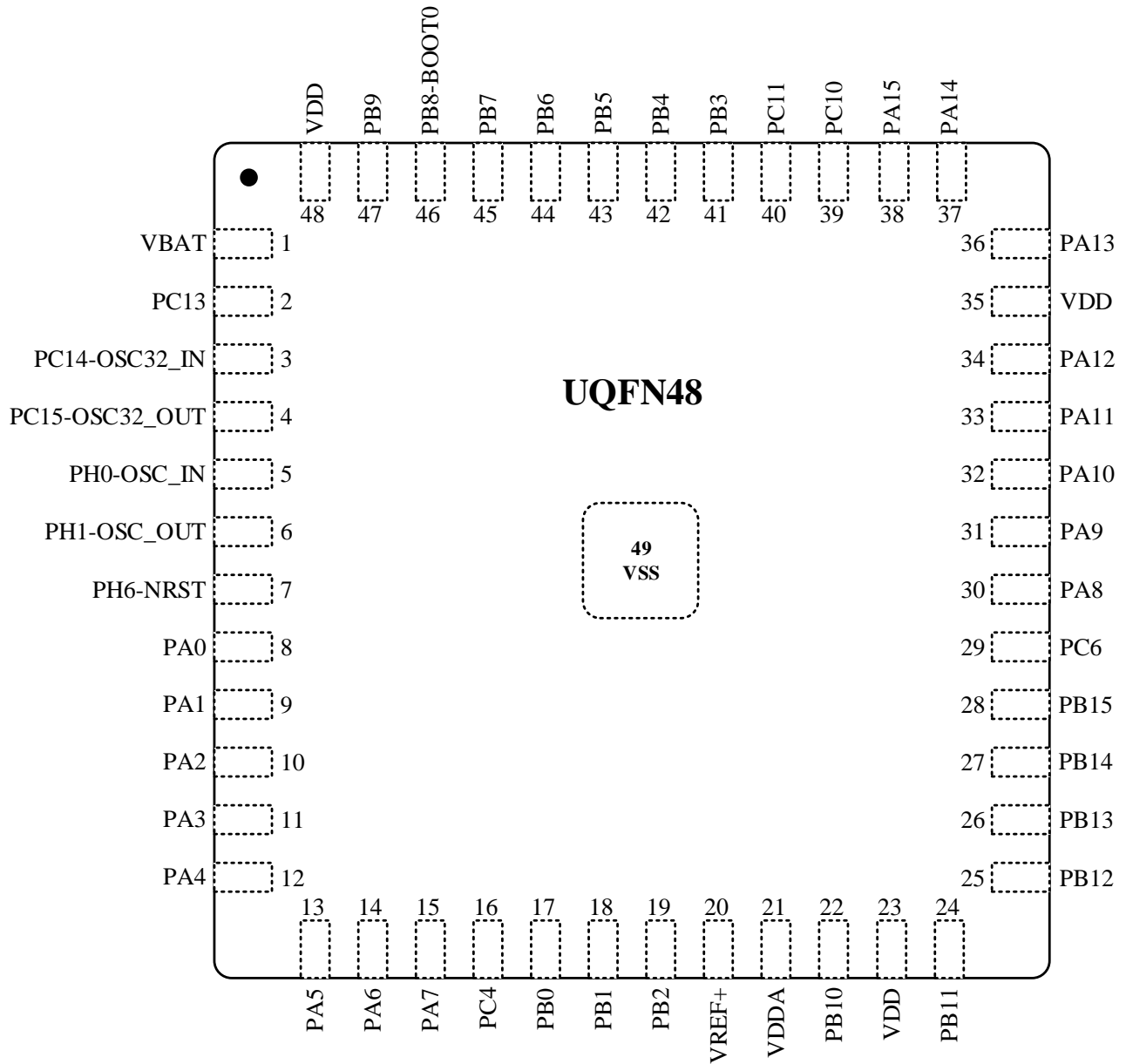

3.1.3 LQFP48

Figure 3-3 LQFP48 Pinout

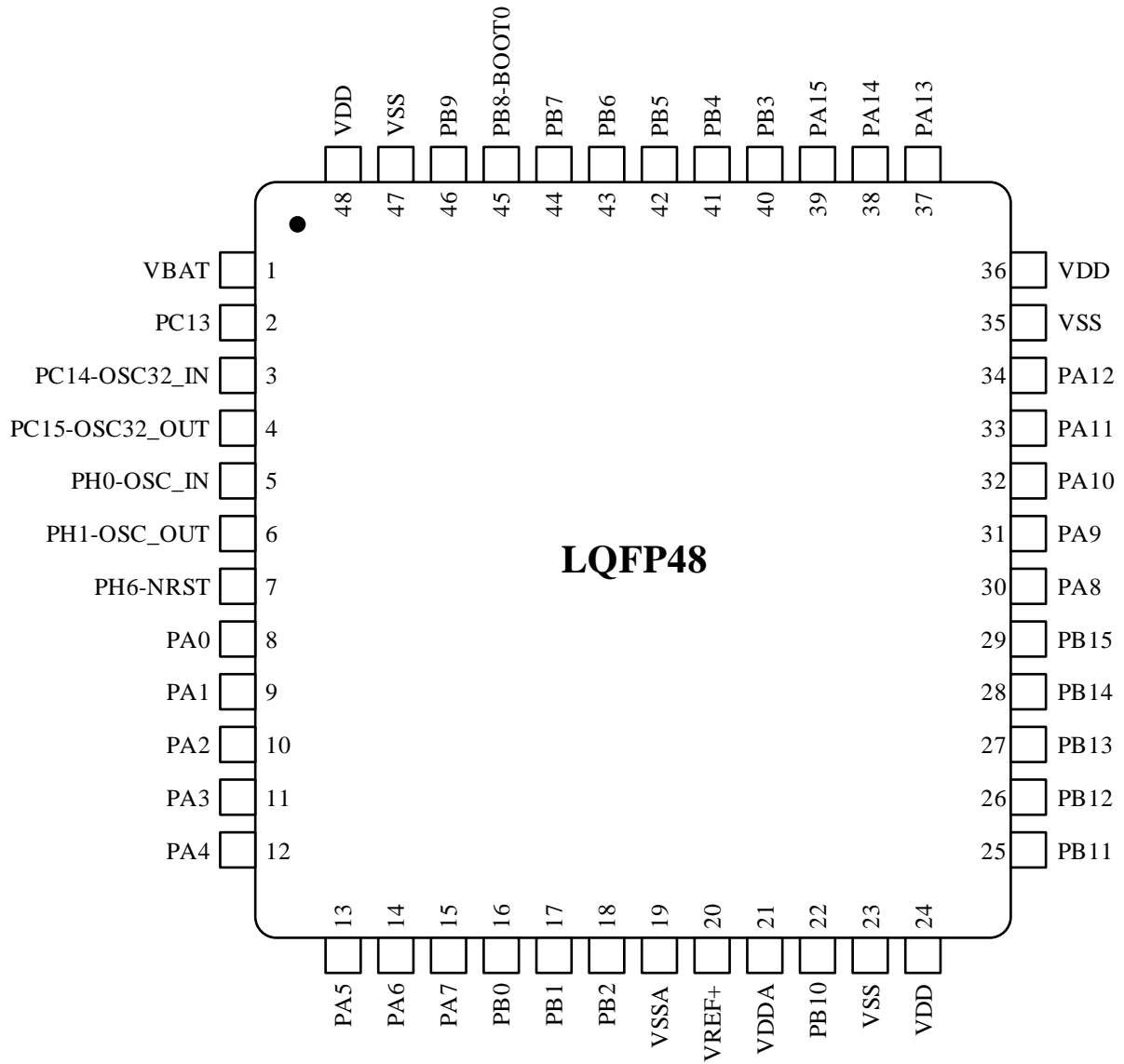

3.1.4 LQFP64

Figure 3-4 LQFP64 Pinout

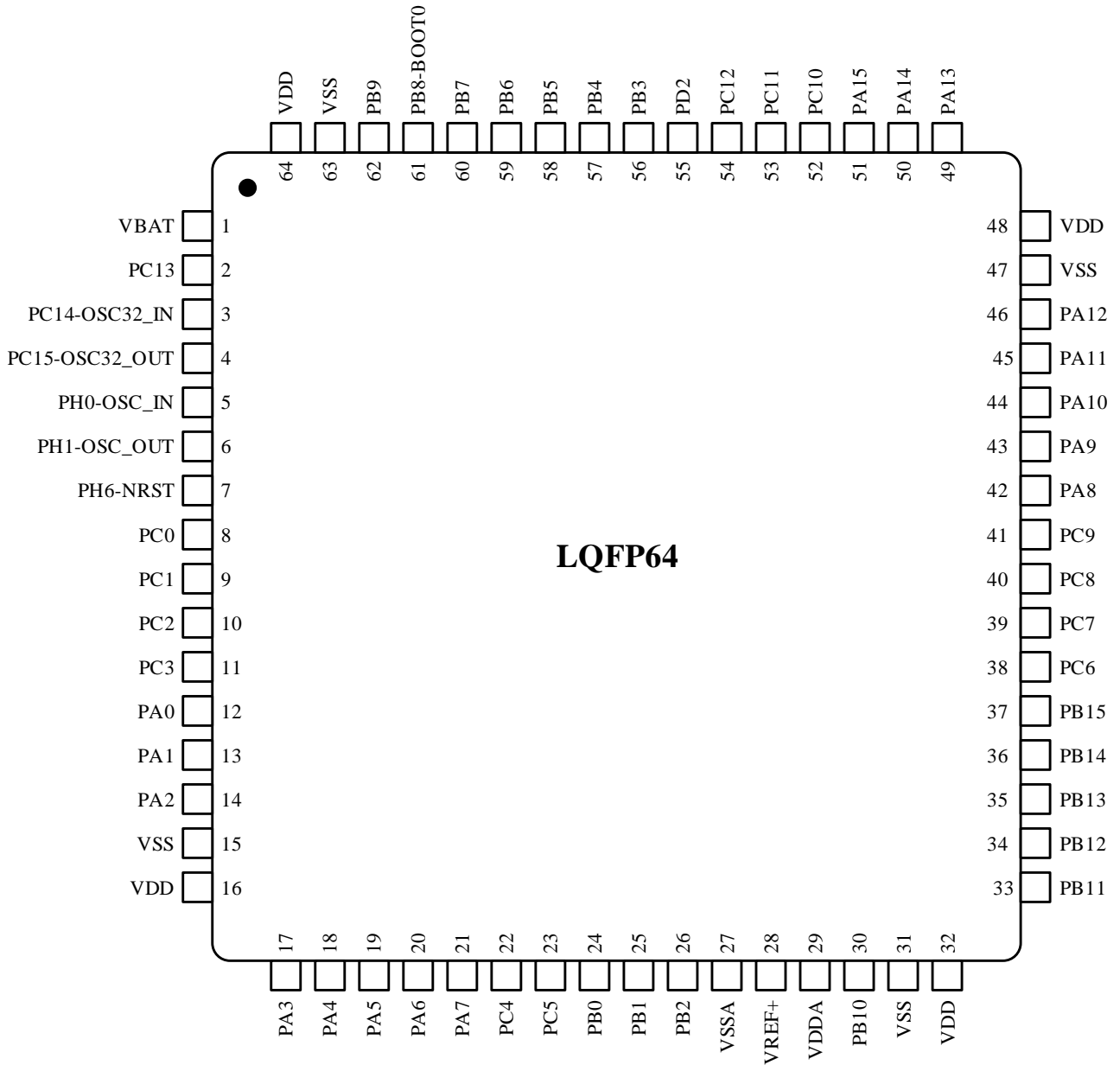

3.1.5 LQFP80

Figure 3-5 LQFP80 Pinout

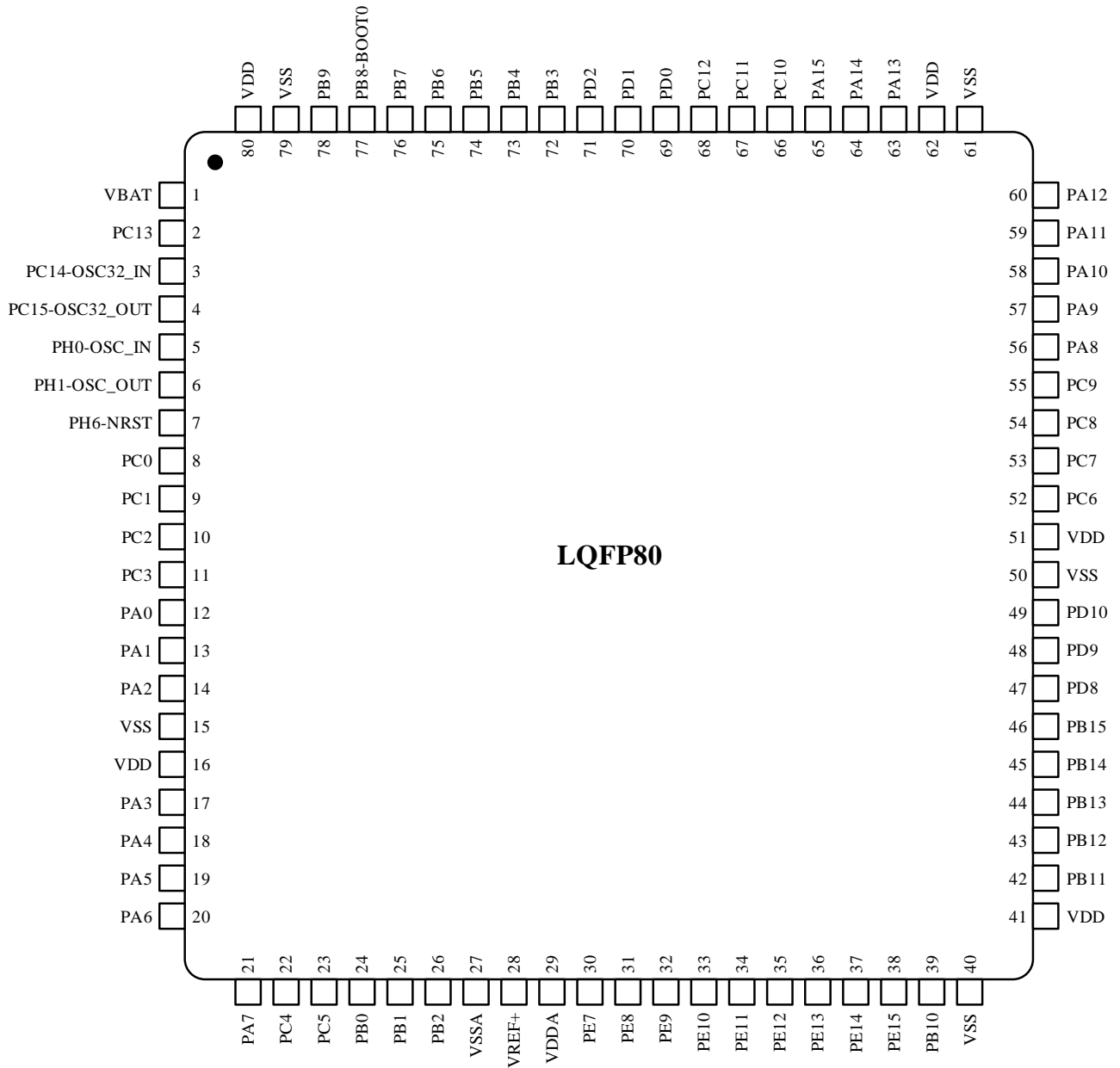

3.1.6 LQFP100

Figure 3-6 LQFP100 Pinout

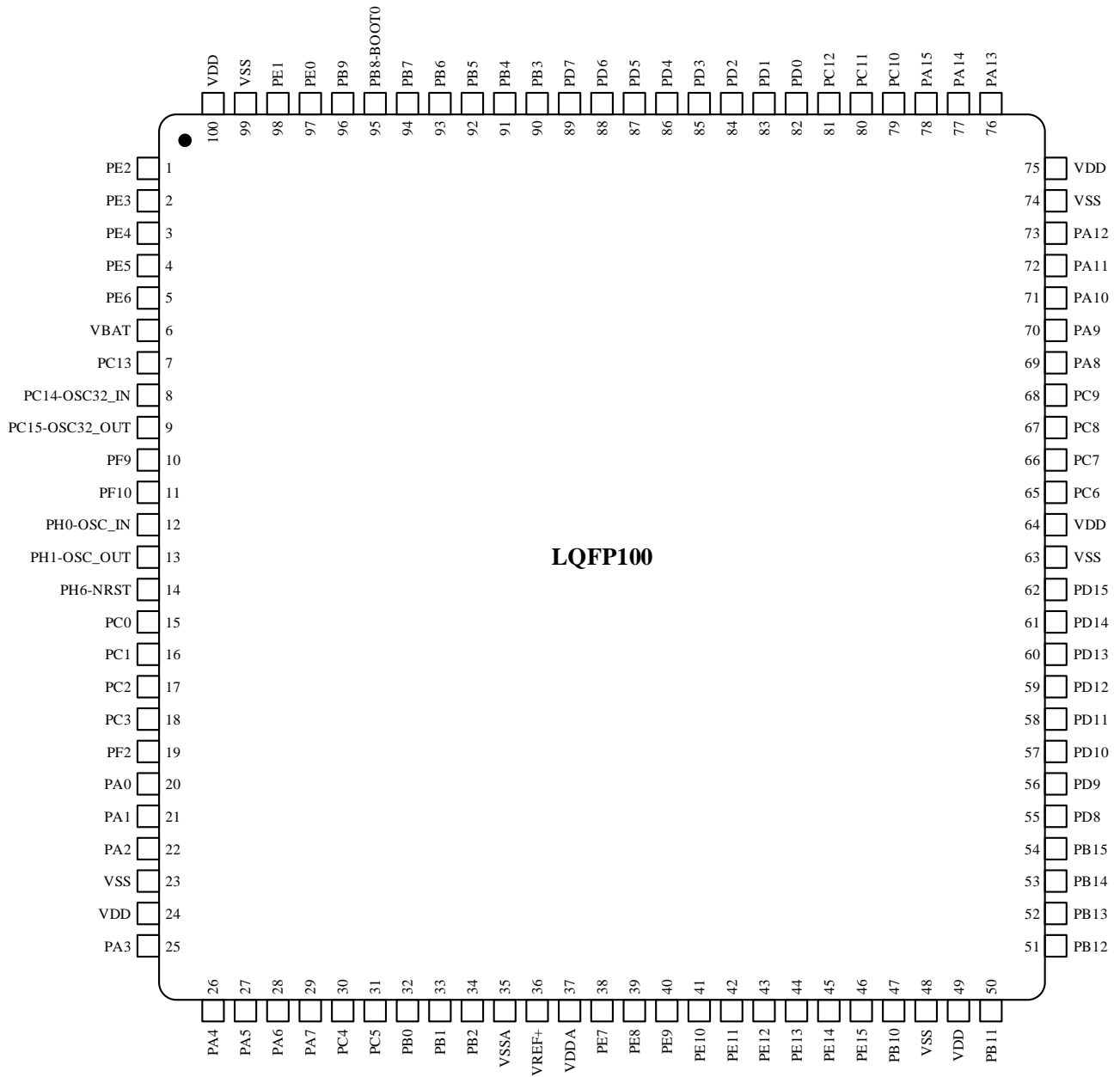

3.1.7 LQFP128

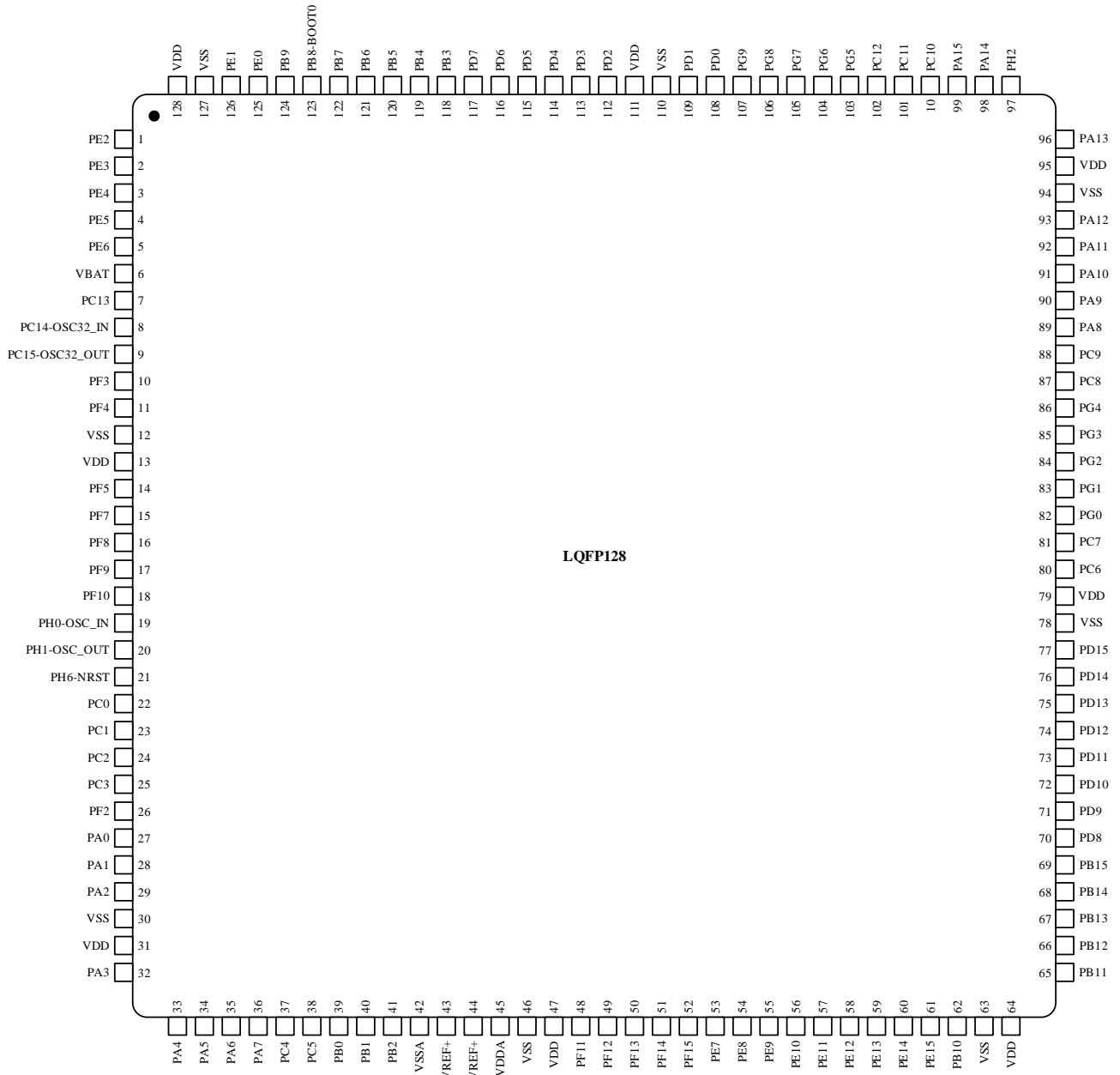
Figure 3-7 LQFP128 Pinout

3.2 Pin Description

Table 3-1 Pin Description

Package							Pin Name	Type ⁽¹⁾	I/O Structure ⁽²⁾	Fail-safe ⁽³⁾	Main Function (After reset)	Pin Functions	
QFN32	UQFN48	LQFP48	LQFP64	LQFP80	LQFP100	LQFP128						Alternate Functions	Additional Functions
-	-	-	-	-	1	1	PE2	I/O	FT	Yes	PE2	GTIM2_CH1 SPI4_SCK ATIM3_CH1 USART4_TX FEMC_A23 EVENTOUT	-
-	-	-	-	-	2	2	PE3	I/O	FT	Yes	PE3	GTIM2_CH2 SPI4_NSS ATIM3_CH2 USART4_RX FEMC_A19 EVENTOUT	-
-	-	-	-	-	3	3	PE4	I/O	FT	Yes	PE4	GTIM2_CH3 SPI4_NSS ATIM3_CH1N FEMC_A20 EVENTOUT	-
-	-	-	-	-	4	4	PE5	I/O	FT	Yes	PE5	GTIM5_CH1 GTIM2_CH4 SPI4_MISO ATIM3_CH2N FEMC_A21 EVENTOUT	-
-	-	-	-	-	5	5	PE6	I/O	FT	Yes	PE6	GTIM5_CH2 SPI4_MOSI ATIM3_CH3N LPTIM2_IN1 FEMC_A22 EVENTOUT	WKUP0 RTC_TAMP3
-	1	1	1	1	6	6	VBAT	S	-	-	VBAT	-	-
-	2	2	2	2	7	7	PC13	I/O	FT	Yes	PC13	RTC_OUT1 ATIM1_CH1N ATIM1_BKIN ATIM2_CH4N LPTIM2_ETR ATIM3_BKIN EVENTOUT	WKUP2 RTC_TAMP1
-	3	3	3	3	8	8	PC14-OSC32_IN	I/O	FT	Yes	PC14	GTIM7_CH3 EVENTOUT	OSC32_IN
-	4	4	4	4	9	9	PC15-OSC32_OUT	I/O	FT	Yes	PC15	GTIM7_CH4 EVENTOUT	OSC32_OUT
-	-	-	-	-	-	10	PF3	I/O	FTa	Yes	PF3	ATIM3_CH4 I2C3_SCL XSPI_IO1 FEMC_A3 EVENTOUT	ADC3_IN17
-	-	-	-	-	-	11	PF4	I/O	FTa	Yes	PF4	ATIM3_CH1N COMP1_OUT I2C3_SDA XSPI_IO2 GTIM5_CH1 I2C3_SCL	ADC3_IN0

Package							Pin Name	Type ⁽¹⁾	I / O Structure ⁽²⁾	Fail-safe ⁽³⁾	Main Function (After reset)	Pin Functions	
QFN32	UQFN48	LQFP48	LQFP64	LQFP80	LQFP100	LQFP128						Alternate Functions	Additional Functions
												FEMC_A4 EVENTOUT	
-	-	-	-	-	-	12	VSS	S	-	-	VSS	-	-
-	-	-	-	-	-	13	VDD	S	-	-	VDD	-	-
-	-	-	-	-	-	14	PF5	I/O	FTa	Yes	PF5	ATIM3_CH2N XSPI_IO3 GTIM5_CH2 I2C3_SDA FEMC_A5 EVENTOUT	ADC3_IN13
-	-	-	-	-	-	15	PF7	I/O	FTa	Yes	PF7	GTIM7_CH1 ATIM3_BKIN GTIM4_CH2 XSPI_IO2 SPI5_SCK UART7_TX GTIM8_ETR FEMC_A1 EVENTOUT	ADC1_IN15 PGA1_VINP PGA2_VINP PGA3_VINP
-	-	-	-	-	-	16	PF8	I/O	FTa	Yes	PF8	GTIM9_CH1 ATIM3_BKIN2 GTIM4_CH3 XSPI_IO0 SPI5_MISO FEMC_A24 EVENTOUT	ADC2_IN1 PGA1_VINM COMP1_INP
-	-	-	-	-	10	17	PF9	I/O	FTa	Yes	PF9	GTIM10_CH1 ATIM3_BKIN GTIM8_CH1 SPI2_SCK GTIM4_CH4 XSPI_IO1 SPI5_MOSI FEMC_A25 EVENTOUT	ADC4_IN17 PGA2_VINM
-	-	-	-	-	11	18	PF10	I/O	FTa	Yes	PF10	ATIM3_BKIN2 GTIM8_CH2 SPI2_SCK XSPI_CLK FEMC_A0 EVENTOUT	ADC4_IN0 PGA1_VINM PGA2_VINM PGA3_VINM PGA4_VINM COMP2_INP
2	5	5	5	5	12	19	PH0-OSC_IN	I/O	FTa	Yes	PH0	I2C2_SDA SPI2_NSS/I2S2_WS ATIM1_CH3N USART2_RX GTIM5_CH3 ATIM3_CH1N EVENTOUT	OSC_IN ADC1_IN10
3	6	6	6	6	13	20	PH1-OSC_OUT	I/O	FTa	Yes	PH1	I2C2_SCL SPI2_SCK/I2S2_CK USART2_TX GTIM5_CH4 ATIM3_CH2N EVENTOUT	OSC_OUT ADC2_IN10 COMP3_INM COMP3_INP
4	7	7	7	7	14	21	PH6-NRST	I/O	RST	Yes	NRST	MCO1 EVENTOUT	NRST

Package							Pin Name	Type ⁽¹⁾	I / O Structure ⁽²⁾	Fail-safe ⁽³⁾	Main Function (After reset)	Pin Functions	
QFN32	UQFN48	LQFP48	LQFP64	LQFP80	LQFP100	LQFP128						Alternate Functions	Additional Functions
-	-	-	8	8	15	22	PC0	I/O	FTa	Yes	PC0	LPTIM1_IN1 ATIM1_CH1 UART7_RX I2C3_SCL USART4_TX XSPI_RXDS GTIM10_CH1 EVENTOUT	ADC12_IN6 COMP7_INM COMP3_INM PGA3_VINP COMP3_INP
-	-	-	9	9	16	23	PC1	I/O	FTa	Yes	PC1	LPTIM1_OUT ATIM1_CH2 UART7_TX XSPI_IO4 SPI3_MOSI/I2S3_SD SPI2_MOSI/I2S2_SD I2C3_SDA USART4_RX GTIM10_CH2 EVENTOUT	ADC12_IN7 COMP7_INP COMP3_INP PGA3_VINM COMP1_INP
-	-	-	10	10	17	24	PC2	I/O	FTa	Yes	PC2	SPI2_MISO I2S2_AUX_SD LPTIM1_IN2 ATIM1_CH3 COMP3_OUT COMP7_OUT ATIM3_CH2 XSPI_IO5 SPI3_NSS/I2S3_WS GTIM10_CH3 UAR7_TX EVENTOUT	ADC12_IN8 PGA1_VINP
-	-	-	11	11	18	25	PC3	I/O	FTa	Yes	PC3	SPI2_MOSI/I2S2_SD LPTIM1_ETR ATIM1_CH4 ATIM1_BKIN2 XSPI_IO6 SPI3_SCK/I2S3_CK GTIM10_CH4 UAR7_RX EVENTOUT	ADC12_IN9 PGA2_VINP PGA3_VINP PGA4_VINP COMP5_INP PGA1_VINM COMP2_INP
-	-	-	-	-	19	26	PF2	I/O	FTa	Yes	PF2	I2C2_SMBA ATIM3_CH3 XSPI_IO0 FEMC_A2 EVENTOUT	ADC1_IN13
5	8	8	12	12	20	27	PA0-WKUP1	I/O	FTa	Yes	PA0	USART2_CTS UART6_TX GTIM1_CH1_ETR GTIM4_CH1 ATIM2_ETR COMP1_OUT ATIM2_BKIN SPI3_MISO ATIM3_CH3N EVENTOUT	ADC12_IN3 WKUP1 COMP1_INM COMP3_INP RTC_TAMP2
6	9	9	13	13	21	28	PA1	I/O	FTa	Yes	PA1	USART2_RTS_DE UART6_RX GTIM4_CH2	ADC12_IN4 COMP1_INP PGA1_VINP

Package							Pin Name	Type ⁽¹⁾	I / O Structure ⁽²⁾	Fail-safe ⁽³⁾	Main Function (After reset)	Pin Functions	
QFN32	UQFN48	LQFP48	LQFP64	LQFP80	LQFP100	LQFP128						Alternate Functions	Additional Functions
												GTIM1_CH2 RTC_REFIN GTIM8_CH1N SPI4_MOSI SPI3_MOSI/I2S3_SD SPI6_SCK ATIM3_CH4N EVENTOUT	PGA3_VINP PGA4_VINM PGA2_VINP RTC_REFIN
7	10	10	14	14	22	29	PA2	I/O	FTa	Yes	PA2	USART2_TX GTIM4_CH3 GTIM5_CH1 GTIM1_CH3 COMP2_OUT GTIM8_CH1_ETR XSPI_NSS0 UART7_TX I2S_CKIN COMP3_OUT SPI6_NSS EVENTOUT	ADC1_IN5 COMP2_INM PGA1_VINM PGA2_VINM PGA2_VINP WKUP3 PGA3_VINM LSCO
-	-	-	15	15	23	30	VSS	S	-	-	VSS	-	-
-	-	-	16	16	24	31	VDD	S	-	-	VDD	-	-
8	11	11	17	17	25	32	PA3	I/O	FTa	Yes	PA3	USART2_RX GTIM4_CH4 GTIM5_CH2 GTIM1_CH4 GTIM8_CH2 XSPI_CLK UART7_RX I2S2_MCK MCO2 EVENTOUT	ADC1_IN2 PGA1_VINM PGA1_VINP COMP2_INP PGA2_VINM COMP5_INP
9	12	12	18	18	26	33	PA4	I/O	TTa	Yes	PA4	SPI1_NSS SPI3_NSS/I2S3_WS USART2_CK GTIM2_CH2 XSPI_NSS1 I2C2_SCL SPI6_MISO GTIM7_CH1 LPTIM2_IN2 USART1_TX EVENTOUT	ADC2_IN17 DAC1_OUT COMP1_INM COMP2_INM COMP3_INM COMP4_INM COMP5_INM COMP6_INM COMP7_INM PGA4_VINP PGA2_VINP
10	13	13	19	19	27	34	PA5	I/O	TTa	Yes	PA5	SPI1_SCK GTIM1_CH1_ETR ATIM2_CH1N XSPI_CLK I2C2_SDA SPI6_MOSI USART1_RX XSPI_IO0 GTIM7_CH2 EVENTOUT	ADC2_IN13 DAC2_OUT COMP1_INM COMP2_INM COMP3_INM COMP4_INM COMP5_INM COMP6_INM COMP7_INM PGA1_VINP PGA2_VINM PGA3_VINP PGA1_VINM PGA3_VINM

Package							Pin Name	Type ⁽¹⁾	I / O Structure ⁽²⁾	Fail-safe ⁽³⁾	Main Function (After reset)	Pin Functions	
QFN32	UQFN48	LQFP48	LQFP64	LQFP80	LQFP100	LQFP128						Alternate Functions	Additional Functions
11	14	14	20	20	28	35	PA6	I/O	TTa	Yes	PA6	SPI1_MISO ATIM2_BKIN GTIM9_CH1 GTIM2_CH1 ATIM1_BKIN COMP1_OUT XSPI_IO3 UART7_CTS I2S2_MCK XSPI_IO0 COMP2_OUT EVENTOUT	ADC2_IN0 DAC3_OUT COMP1_INM PGA3_VINP
12	15	15	21	21	29	36	PA7	I/O	TTa	Yes	PA7	SPI1_MOSI ATIM2_CH1N GTIM7_CH1 GTIM2_CH2 ATIM1_CH1N GTIM10_CH1 COMP2_OUT XSPI_IO2 XSPI_IO1 MCO1 GTIM9_CH2 EVENTOUT	ADC2_IN2 COMP2_INP PGA1_VINP PGA2_VINP COMP6_INM DAC4_OUT COMP1_INP
-	16	-	22	22	30	37	PC4	I/O	FTa	Yes	PC4	ATIM1_ETR I2C2_SCL USART1_TX XSPI_IO7 XSPI_IO2 UART7_TX I23_SCL LPTIM2_OUT ATIM3_CH3N EVENTOUT	ADC2_IN5 PGA3_VINM COMP4_INM COMP5_INP
-	-	-	23	23	31	38	PC5	I/O	FTa	Yes	PC5	GTIM8_BKIN ATIM1_CH4N USART1_RX XSPI_IO3 UART7_RX COMP4_OUT I2C3_SDA GTIM5_ETR EVENTOUT	ADC2_IN11 PGA1_VINM PGA2_VINM PGA4_VINP COMP6_INP WKUP4
13	17	16	24	24	32	39	PB0	I/O	FTa	Yes	PB0	GTIM2_CH3 ATIM2_CH2N ATIM1_CH2N XSPI_IO1 SHRTIM1_FAULT5 SPI5_SCK SPI3_MOSI/I2S3_SD COMP5_OUT USART4_TX EVENTOUT	ADC3_IN12 COMP4_INP PGA2_VINP PGA3_VINP COMP3_INP PGA2_VINM ADC1_IN1
-	18	17	25	25	33	40	PB1	I/O	FTa	Yes	PB1	GTIM2_CH4 ATIM2_CH3N ATIM1_CH3N COMP4_OUT	ADC1_IN12 COMP1_INP PGA4_VINM COMP2_INM COMP2_INP

Package							Pin Name	Type ⁽¹⁾	I / O Structure ⁽²⁾	Fail-safe ⁽³⁾	Main Function (After reset)	Pin Functions	
QFN32	UQFN48	LQFP48	LQFP64	LQFP80	LQFP100	LQFP128						Alternate Functions	Additional Functions
												XSPI_IO0 UART7_RTS_DE SHRTIM1_SCOUT SPI5_NSS USART4_RX COMP1_OUT EVENTOUT	PGA1_VINP ADC3_IN1
-	19	18	26	26	34	41	PB2	I/O	FTa	Yes	PB2	RTC_OUT2 LPTIM1_OUT GTIM4_CH1 ATIM3_CH1 I2C3_SMBA XSPI_IO5 SHRTIM1_SCIN GTIM1_CH4 SPI3_MOSI/I2S3_SD UART6_TX SPI1_NSS GTIM6_ETR EVENTOUT	ADC2_IN12 COMP4_INM PGA3_VINM
14	-	19	27	27	35	42	VSSA	S	-	-	VSSA	-	-
14	-	19	27	27	35	-	VREF-	S	-	-	VREF-	-	-
-	-	-	-	-	-	43	VREF+	S	-	-	VREF+	-	-
15	20	20	28	28	36	44	VREF+	S	-	-	VREF+	-	-
15	21	21	29	29	37	45	VDDA	S	-	-	VDDA	-	-
16	-	-	-	-	-	46	VSS	S	-	-	VSS	-	-
17	-	-	-	-	-	47	VDD	S	-	-	VDD	-	-
-	-	-	-	-	-	48	PF11	I/O	FT	Yes	PF11	ATIM3_ETR SPI5_MOSI FEMC_NE4 EVENTOUT	-
-	-	-	-	-	-	49	PF12	I/O	FT	Yes	PF12	ATIM3_CH1 FEMC_A6 EVENTOUT	-
-	-	-	-	-	-	50	PF13	I/O	FT	Yes	PF13	ATIM3_CH2 I2C4_SMBA MCO1 FEMC_A7 EVENTOUT	-
-	-	-	-	-	-	51	PF14	I/O	FT	Yes	PF14	ATIM3_CH3 I2C4_SCL MCO2 FEMC_A8 EVENTOUT	-
-	-	-	-	-	-	52	PF15	I/O	FT	Yes	PF15	ATIM3_CH4 I2C4_SDA FEMC_A9 EVENTOUT	-
-	-	-	-	30	38	53	PE7	I/O	FTa	Yes	PE7	ATIM1_ETR UART7_RX UART6_RX SPI1_SCK GTIM4_CH2 GTIM9_CH4 FEMC_D4 EVENTOUT	ADC3_IN4 COMP4_INP COMP3_INM

Package							Pin Name	Type ⁽¹⁾	I/O Structure ⁽²⁾	Fail-safe ⁽³⁾	Main Function (After reset)	Pin Functions	
QFN32	UQFN48	LQFP48	LQFP64	LQFP80	LQFP100	LQFP128						Alternate Functions	Additional Functions
-	-	-	-	31	39	54	PE8	I/O	FTa	Yes	PE8	ATIM1_CH1N GTIM4_CH3 UART7_TX SPI1_MISO FEMC_D5 EVENTOUT	ADC34_IN6 COMP4_INM PGA2_VINP COMP2_INM
-	-	-	-	32	40	55	PE9	I/O	FTa	Yes	PE9	ATIM1_CH1 GTIM4_CH4 SPI1_MOSI FEMC_D6 EVENTOUT	ADC3_IN2
-	-	-	-	33	41	56	PE10	I/O	FTa	Yes	PE10	ATIM1_CH2N XSPI_CLK SPI2_NSS/I2S2_WS ATIM1_CH1N GTIM2_CH1 GTIM9_CH1 USART4_TX FEMC_D7 EVENTOUT	ADC34_IN14
-	-	-	-	34	42	57	PE11	I/O	FTa	Yes	PE11	ATIM1_CH2 SPI4_NSS XSPI_NSS0 SPI5_NSS SPI2_SCK/I2S2_CK USART4_RX FEMC_D8 EVENTOUT	ADC34_IN15
-	-	-	-	35	43	58	PE12	I/O	FTa	Yes	PE12	ATIM1_CH3N SPI4_SCK XSPI_IO0 SPI5_SCK SPI2_MISO GTIM7_CH4 FEMC_D9 EVENTOUT	ADC34_IN16
-	-	-	-	36	44	59	PE13	I/O	FTa	Yes	PE13	ATIM1_CH3 SPI4_MISO XSPI_IO1 SPI5_MISO SPI2_MOSI/I2S2_SD FEMC_D10 EVENTOUT	ADC3_IN3
-	-	-	-	37	45	60	PE14	I/O	FTa	Yes	PE14	ATIM1_CH4 SPI4_MOSI ATIM1_BKIN2 XSPI_IO2 SPI5_MOSI FEMC_D11 EVENTOUT	ADC4_IN5
-	-	-	-	38	46	61	PE15	I/O	FTa	Yes	PE15	ATIM1_BKIN ATIM1_CH4N XSPI_IO3 I2C1_SDA USART4_RX GTIM10_CH1	ADC4_IN2

Package							Pin Name	Type ⁽¹⁾	I/O Structure ⁽²⁾	Fail-safe ⁽³⁾	Main Function (After reset)	Pin Functions	
QFN32	UQFN48	LQFP48	LQFP64	LQFP80	LQFP100	LQFP128						Alternate Functions	Additional Functions
												FEMC_D12 EVENTOUT	
-	22	22	30	39	47	62	PB10	I/O	FTa	Yes	PB10	SPI2_SCK/I2S2_CK I2C2_SCL GTIM1_CH3 UART7_RX XSPI_CLK ATIM1_BKIN SHRTIM1_FALT3 COMP3_OUT FEMC_D11 EVENTOUT	COMP5_INM PGA3_VINM PGA4_VINM COMP1_INP
-	-	23	31	40	48	63	VSS	S	-	-	VSS	-	-
-	23	24	32	41	49	64	VDD	S	-	-	VDD	-	-
-	24	25	33	42	50	65	PB11	I/O	FTa	Yes	PB11	I2C2_SDA GTIM1_CH4 UART7_TX XSPI_NSS0 I2S_CKIN SHRTIM1_FALT4 COMP5_OUT FEMC_D12 EVENTOUT	ADC12_IN14 COMP6_INP PGA4_VINP COMP2_INP
-	25	26	34	43	51	66	PB12	I/O	FTa	Yes	PB12	SPI2_NSS/I2S2_WS I2C2_SMBA USART3_CK ATIM1_BKIN GTIM4_ETR UART7_RTS_DE SHRTIM1_CHC1 SPI4_NSS COMP4_OUT GTIM9_CH3 EVENTOUT	COMP3_INM ADC1_IN11 COMP7_INM PGA4_VINP ADC4_IN1
-	26	27	35	44	52	67	PB13	I/O	FTa	Yes	PB13	SPI2_SCK/I2S2_CK USART3_CTS ATIM1_CH1N UART7_CTS SHRTIM1_CHC2 SPI4_SCK ATIM1_CH2 GTIM10_CH2 GTIM9_CH4 EVENTOUT	ADC3_IN5 COMP5_INP PGA3_VINP PGA4_VINP COMP4_INM
-	27	28	36	45	53	68	PB14	I/O	FTa	Yes	PB14	SPI2_MISO ATIM1_CH2N GTIM8_CH1 ATIM2_CH2N I2S2_AUX_SD COMP4_OUT SHRTIM1_CHD1 GTIM9_CH2 USART4_CK EVENTOUT	ADC4_IN4 COMP3_INP PGA2_VINP ADC1_IN0 COMP7_INP COMP3_INM
-	28	29	37	46	54	69	PB15	I/O	FTa	Yes	PB15	SPI2_MOSI/I2S2_SD ATIM1_CH3N ATIM2_CH3N	RTC_REFIN COMP6_INM ADC2_IN15

Package							Pin Name	Type ⁽¹⁾	I / O Structure ⁽²⁾	Fail-safe ⁽³⁾	Main Function (After reset)	Pin Functions	
QFN32	UQFN48	LQFP48	LQFP64	LQFP80	LQFP100	LQFP128						Alternate Functions	Additional Functions
												GTIM8_CH2 GTIM8_CH1N COMP3_OUT SHRTIM1_CHD2 ATIM2_CH4 UART8_CTS EVENTOUT	PGA2_VINM COMP4_INP ADC4_IN3
-	-	-	-	47	55	70	PD8	I/O	FTa	Yes	PD8	SPI3_NSS/I2S3_WS ATIM1_CH3 GTIM10_CH1 FEMC_D13 EVENTOUT	ADC4_IN12 PGA4_VINM COMP6_INM
-	-	-	-	48	56	71	PD9	I/O	FTa	Yes	PD9	SPI3_SCK/I2S3_CK ATIM1_CH3N GTIM9_CH3 GTIM7_ETR GTIM10_CH2 FEMC_D14 EVENTOUT	ADC4_IN13 PGA4_VINP COMP6_INP
-	-	-	-	49	57	72	PD10	I/O	FTa	Yes	PD10	USART3_CK ATIM1_CH4 ATIM3_ETR FEMC_D15 EVENTOUT	ADC34_IN7 COMP6_INM COMP5_INM
-	-	-	-	-	58	73	PD11	I/O	FTa	Yes	PD11	USART3_CTS GTIM4_ETR I2C4_SMBA SPI3_MISO USART4_TX I2C1_SCL GTIM10_CH3 FEMC_CLE/FEMC_A16 EVENTOUT	ADC34_IN8 PGA4_VINP COMP6_INP
-	-	-	-	-	59	74	PD12	I/O	FTa	Yes	PD12	GTIM3_CH1 SPI3_MOSI/I2S3_SD COMP7_OUT GTIM6_CH1 FEMC_ALE/FEMC_A17 EVENTOUT	ADC34_IN9 COMP5_INP PGA2_VINP
-	-	-	-	-	60	75	PD13	I/O	FTa	Yes	PD13	GTIM3_CH2 XSPI_RXDS GTIM6_CH2 FEMC_A18 EVENTOUT	ADC34_IN10 COMP5_INM
-	-	-	-	-	61	76	PD14	I/O	FTa	Yes	PD14	GTIM3_CH3 I2C4_SCL ATIM2_CH1 GTIM10_CH4 GTIM6_CH3 FEMC_D0 EVENTOUT	ADC34_IN11 PGA2_VINP COMP7_INP
-	-	-	-	-	62	77	PD15	I/O	FTa	Yes	PD15	GTIM3_CH4 SPI2_NSS I2C4_SDA ATIM2_CH2 ATIM2_CH1N	COMP3_INM COMP7_INM COMP3_INP

Package							Pin Name	Type ⁽¹⁾	I / O Structure ⁽²⁾	Fail-safe ⁽³⁾	Main Function (After reset)	Pin Functions	
QFN32	UQFN48	LQFP48	LQFP64	LQFP80	LQFP100	LQFP128						Alternate Functions	Additional Functions
-	-	-	-	50	63	78	VSS	S	-	-	VSS	GTIM8_CH1 GTIM6_CH4 FEMC_D1 EVENTOUT	-
-	-	-	-	51	64	79	VDD	S	-	-	VDD	-	-
-	29	-	38	52	65	80	PC6	I/O	FT	Yes	PC6	I2S2_MCK ATIM2_CH1 USART4_TX GTIM2_CH1 COMP6_OUT I2C4_SCL SHRTIM1_CHF1 SPI2_NSS/I2S2_WS USART2_CTS ATIM2_CH2 FEMC_A16 EVENTOUT	-
-	-	-	39	53	66	81	PC7	I/O	FT	Yes	PC7	I2S3_MCK ATIM2_CH2 USART4_RX GTIM2_CH2 SHRTIM1_FAULT5 COMP5_OUT I2C4_SDA SHRTIM1_CHF2 SPI2_SCK/I2S_CK USART2_RTS_DE ATIM2_CH2N GTIM8_CH2 FEMC_A17 EVENTOUT	-
-	-	-	-	-	-	82	PG0	I/O	FT	Yes	PG0	ATIM3_CH1N UART7_TX GTIM7_CH2 FEMC_A10 EVENTOUT	-
-	-	-	-	-	-	83	PG1	I/O	FT	Yes	PG1	ATIM3_CH2N UART7_RX GTIM7_CH3 FEMC_A11 EVENTOUT	-
-	-	-	-	-	-	84	PG2	I/O	FT	Yes	PG2	ATIM3_CH3N SPI1_SCK I2C2_SCL GTIM5_ETR FEMC_A12 EVENTOUT	-
-	-	-	-	-	-	85	PG3	I/O	FT	Yes	PG3	ATIM3_BKIN I2C4_SCL SPI1_MISO ATIM3_CH4N I2C2_SDA FEMC_A13 EVENTOUT	-
-	-	-	-	-	-	86	PG4	I/O	FT	Yes	PG4	ATIM3_BKIN2 I2C4_SDA	-

Package							Pin Name	Type ⁽¹⁾	I / O Structure ⁽²⁾	Fail-safe ⁽³⁾	Main Function (After reset)	Pin Functions	
QFN32	UQFN48	LQFP48	LQFP64	LQFP80	LQFP100	LQFP128						Alternate Functions	Additional Functions
												SPI1_MOSI GTIM6_ETR FEMC_A14 EVENTOUT	
-	-	-	40	54	67	87	PC8	I/O	FT	Yes	PC8	ATIM2_CH3 GTIM2_CH3 USART4_CK SHRTIM1_CHE1 COMP3_OUT ATIM3_CH3 COMP7_OUT I2C3_SCL SPI2_MISO USART2_TX EVENTOUT	-
-	-	-	41	55	68	88	PC9	I/O	FTa	Yes	PC9	I2S_CKIN MCO2 ATIM2_CH4 I2C3_SDA GTIM2_CH4 SHRTIM1_CHE2 ATIM2_BKIN2 COMP6_OUT SPI2_MOSI/I2S2_SD USART2_RX ATIM2_CH3N GTIM8_CH3 FEMC_NOE EVENTOUT	PGA3_VINP PGA4_VINM COMP4_INP
18	30	30	42	56	69	89	PA8	I/O	FTa	Yes	PA8	MCO1 USART1_CK ATIM1_CH1 I2C3_SCL I2C2_SDA I2S2_MCK I2C2_SMBA COMP7_OUT GTIM3_ETR SHRTIM1_CHA1 COMP3_OUT EVENTOUT	ADC3_IN18
19	31	31	43	57	70	90	PA9	I/O	FTa	Yes	PA9	USART1_TX ATIM1_CH2 I2C3_SMBA I2C2_SCL I2S3_MCK COMP5_OUT GTIM8_BKIN GTIM1_CH3 SHRTIM1_CHA2 SPI2_SCK/I2S2_CK I2C4_SCL I2C1_SCL EVENTOUT	ADC4_IN18
20	32	32	44	58	71	91	PA10	I/O	FT	Yes	PA10	USART1_RX ATIM1_CH3 GTIM10_BKIN I2C2_SMBA	PVD_IN

Package							Pin Name	Type ⁽¹⁾	I / O Structure ⁽²⁾	Fail-safe ⁽³⁾	Main Function (After reset)	Pin Functions	
QFN32	UQFN48	LQFP48	LQFP64	LQFP80	LQFP100	LQFP128						Alternate Functions	Additional Functions
												SPI2_MISO COMP6_OUT GTIM1_CH4 ATIM2_BKIN SHRTIM1_CHB1 I2C2_SDA I2S2_AUX_SD SPI5_MOSI I2C4_SDA FEMC_NWE EVENTOUT	
21	33	33	45	59	72	92	PA11	I/O	FT	Yes	PA11	USART1_CTS ATIM1_CH4 USB_FS_DM SPI2_MOSI/I2S2_SD ATIM1_CH1N COMP1_OUT GTIM3_CH1 ATIM1_BKIN2 SHRTIM1_CHB2 SPI4_MISO USART4_TX COMP5_OUT ATIM2_CH3N EVENTOUT	-
22	34	34	46	60	73	93	PA12	I/O	FT	Yes	PA12	USART1_RTS_DE ATIM1_ETR USB_FS_DP GTIM9_CH1 I2S_CKIN ATIM1_CH2N COMP2_OUT GTIM3_CH2 SHRTIM1_FAULT1 SPI4_MOSI USART4_RX COMP6_OUT SPI2_NSS EVENTOUT	-
-	-	35	47	61	74	94	VSS	S	-	-	VSS	-	-
-	35	36	48	62	75	95	VDD	S	-	-	VDD	-	-
23	36	37	49	63	76	96	PA13	I/O	FT	Yes	PA13	JTMS-SWDIO GTIM9_CH1N I2C4_SCL I2C1_SCL IR_OUT USART3_CTS GTIM3_CH3 UART6_TX GTIM8_CH3 EVENTOUT	-
-	-	-	-	-	-	97	PH2	I/O	FTa	Yes	PH2	USART4_RTS_DE USART1_RX GTIM3_CH4 GTIM9_CH3 EVENTOUT	-

Package							Pin Name	Type ⁽¹⁾	I / O Structure ⁽²⁾	Fail-safe ⁽³⁾	Main Function (After reset)	Pin Functions	
QFN32	UQFN48	LQFP48	LQFP64	LQFP80	LQFP100	LQFP128						Alternate Functions	Additional Functions
24	37	38	50	64	77	98	PA14	I/O	FT	Yes	PA14	JTCK-SWCLK LPTIM1_OUT I2C4_SMBA I2C1_SDA ATIM2_CH2 ATIM1_BKIN USART2_TX UART6_RX GTIM8_CH4 EVENTOUT	-
25	38	39	51	65	78	99	PA15	I/O	FT	Yes	PA15	JTDI SPI3_NSS/I2S3_WS GTIM1_CH1_ETR SPI1_NSS ATIM2_CH1 I2C1_SCL USART2_RX UART6_RTS_DE ATIM1_BKIN SHRTIM1_FAULT2 UART1_TX USART2_CTS ATIM2_CH1N ATIM3_ETR EVENTOUT	-
-	39	-	52	66	79	100	PC10	I/O	FT	Yes	PC10	SPI3_SCK/I2S3_CK UART6_TX ATIM2_CH1N SHRTIM1_FAULT6 XSPI_NSS1 COMP3_OUT GTIM9_CH4 EVENTOUT	-
-	40	-	53	67	80	101	PC11	I/O	FT	Yes	PC11	UART6_RX SPI3_MISO I2S3_AUX_SD ATIM2_CH2N I2C3_SDA XSPI_CLK COMP4_OUT GTIM10_ETR ATIM3_CH2 EVENTOUT	-
-	-	-	54	68	81	102	PC12	I/O	FT	Yes	PC12	SPI3_MOSI/I2S3_SD USART3_CK GTIM4_CH2 ATIM2_CH3N I2C2_SDA XSPI_IO0 ATIM2_CH2N ATIM3_CH3 EVENTOUT	-
-	-	-	-	-	-	103	PG5	I/O	FT	Yes	PG5	ATIM3_ETR SPI1_NSS UART7_CTS FEMC_A15 EVENTOUT	-

Package							Pin Name	Type ⁽¹⁾	I / O Structure ⁽²⁾	Fail-safe ⁽³⁾	Main Function (After reset)	Pin Functions	
QFN32	UQFN48	LQFP48	LQFP64	LQFP80	LQFP100	LQFP128						Alternate Functions	Additional Functions
-	-	-	-	-	-	104	PG6	I/O	FT	Yes	PG6	ATIM3_BKIN I2C3_SMBA UART7_RTS_DE FEMC_INT2 EVENTOUT	-
-	-	-	-	-	-	105	PG7	I/O	FT	Yes	PG7	USART4_CK I2C3_SCL UART7_TX FEMC_INT3 EVENTOUT	-
-	-	-	-	-	-	106	PG8	I/O	FT	Yes	PG8	USART4_RTS_DE I2C3_SDA UART7_RX XSPI_NSS1 FEMC_NE3 EVENTOUT	-
-	-	-	-	-	-	107	PG9	I/O	FT	Yes	PG9	USART4_RX SPI3_SCK USART1_TX GTIM8_CH1N SPI2_MOSI GTIM6_CH2 SPI2_MISO FEMC_NE2/ FEMC_NCE3 EVENTOUT	-
-	-	-	-	69	82	108	PD0	I/O	FT	Yes	PD0	ATIM2_CH4N SPI4_MISO SPI3_MOSI UART6_TX XSPI_IO1 ATIM3_CH4 FEMC_D2 EVENTOUT	-
-	-	-	-	70	83	109	PD1	I/O	FT	Yes	PD1	ATIM2_CH4 ATIM2_BKIN2 SPI2_NSS/I2S2_WS UART6_RX XSPI_IO2 I21_SDA FEMC_D3 EVENTOUT	-
-	-	-	-	-	-	110	VSS	S	-	-	VSS	-	-
-	-	-	-	-	-	111	VDD	S	-	-	VDD	-	-
-	-	-	55	71	84	112	PD2	I/O	FT	Yes	PD2	GTIM2_ETR ATIM2_BKIN SPI3_NSS/I2S3_WS XSPI_IO3 ATIM2_CH3N SPI2_MOSI ATIM1_CH4 ATIM2_CH4N ATIM3_CH4 GTIM5_CH2 EVENTOUT	-
-	-	-	-	-	85	113	PD3	I/O	FT	Yes	PD3	USART2_CTS GTIM1_CH1_ETR	-

Package							Pin Name	Type ⁽¹⁾	I / O Structure ⁽²⁾	Fail-safe ⁽³⁾	Main Function (After reset)	Pin Functions	
QFN32	UQFN48	LQFP48	LQFP64	LQFP80	LQFP100	LQFP128						Alternate Functions	Additional Functions
												XSPI_NSS0 SPI2_SCK/I2S2_CK FEMC_CLK EVENTOUT	
-	-	-	-	-	86	114	PD4	I/O	FT	Yes	PD4	USART2_RTS_DE GTIM1_CH2 XSPI_IO4 FEMC_NOE EVENTOUT	-
-	-	-	-	-	87	115	PD5	I/O	FT	Yes	PD5	USART2_TX XSPI_IO5 GTIM6_CH1 ATIM1_CH4N FEMC_NWE EVENTOUT	-
-	-	-	-	-	88	116	PD6	I/O	FT	Yes	PD6	USART2_RX GTIM1_CH4 XSPI_IO6 SPI3_MOSI/I2S3_SD GTIM9_ETR FEMC_NWAIT EVENTOUT	-
-	-	-	-	-	89	117	PD7	I/O	FT	Yes	PD7	USART2_CK GTIM1_CH3 XSPI_IO7 FEMC_NE1/ FEMC_NCE2 EVENTOUT	-
26	41	40	56	72	90	118	PB3	I/O	FT	Yes	PB3	JTDO SPI3_SCK/I2S3_CK GTIM1_CH2 SPI1_SCK GTIM3_ETR ATIM2_CH1N USART2_TX GTIM2_ETR SHRTIM1_SCOUT USART1_RX I2C2_SDA USART2_RTS_DE ATIM2_BKIN EVENTOUT	-
27	42	41	57	73	91	119	PB4	I/O	FT	Yes	PB4	NJTRST SPI3_MISO GTIM2_CH1 SPI1_MISO I2S3_AUX_SD GTIM9_CH1_ETR ATIM2_CH2N USART2_RX GTIM10_BKIN I2C3_SDA ATIM2_ETR LPTIM2_IN1 USART2_TX EVENTOUT	-

Package							Pin Name	Type ⁽¹⁾	I / O Structure ⁽²⁾	Fail-safe ⁽³⁾	Main Function (After reset)	Pin Functions	
QFN32	UQFN48	LQFP48	LQFP64	LQFP80	LQFP100	LQFP128						Alternate Functions	Additional Functions
28	43	42	58	74	92	120	PB5	I/O	FT	Yes	PB5	I2C1_SMBA GTIM2_CH2 SPI1_MOSI SPI3_MOSI/I2S3_SD GTIM9_BKIN ATIM2_CH3N USART2_CK I2C3_SDA GTIM10_CH1 LPTIM1_IN1 UART5_CTS USART2_RX EVENTOUT	-
29	44	43	59	75	93	121	PB6	I/O	FT	Yes	PB6	I2C1_SCL GTIM3_CH1 USART1_TX GTIM9_CH1N ATIM2_CH1 ATIM2_ETR ATIM2_BKIN2 COMP4_OUT LPTIM1_ETR SHRTIM1_SCIN COMP5_OUT FEMC_NE2/ FEMC_NCE3 EVENTOUT	-
30	45	44	60	76	94	122	PB7	I/O	FT	Yes	PB7	I2C1_SDA USART1_RX GTIM3_CH2 GTIM10_CH1N ATIM2_BKIN GTIM2_CH4 I2C4_SDA COMP3_OUT LPTIM_IN2 COMP6_OUT UART6_CTS FEMC_NADV EVENTOUT	PVD_IN
31	46	45	61	77	95	123	PB8-BOOT0	I/O	FT	Yes	PB8	GTIM3_CH3 GTIM6_CH1 I2C1_SCL GTIM9_CH1 COMP1_OUT ATIM2_CH2 ATIM1_BKIN SPI5_MOSI FEMC_NWAIT GTIM9_CH4 EVENTOUT	-
-	47	46	62	78	96	124	PB9	I/O	FT	Yes	PB9	SPI2_NSS/I2S2_WS GTIM3_CH4 GTIM7_CH1 I2C1_SDA GTIM10_CH1 COMP2_OUT	IR-OUT

Package							Pin Name	Type ⁽¹⁾	I/O Structure ⁽²⁾	Fail-safe ⁽³⁾	Main Function (After reset)	Pin Functions	
QFN32	UQFN48	LQFP48	LQFP64	LQFP80	LQFP100	LQFP128						Alternate Functions	Additional Functions
												ATIM2_CH3 ATIM1_CH3N FEMC_NE1/ FEMC_NCE2 EVENTOUT	
-	-	-	-	-	97	125	PE0	I/O	FT	Yes	PE0	GTIM3_ETR ATIM3_ETR ATIM3_CH4N GTIM9_CH1 USART1_TX FEMC_NBL0 EVENTOUT	-
-	-	-	-	-	98	126	PE1	I/O	FT	Yes	PE1	GTIM10_CH1 ATIM3_CH4 USART1_RX FEMC_NBL1 EVENTOUT	-
32	-	47	63	79	99	127	VSS	S	-	-	VSS	-	-
1	48	48	64	80	100	128	VDD	S	-	-	VDD	-	-

Notes:

(1) I = input, O = output, S = power supply.

(2) FT: 5V toleran; FTa: 5V tolerant, support analog peripherals.

(3) Fail-safe indicates that when the chip has no power input, a high input level is added to the IO. The high input level does not flood into the chip, resulting in a certain voltage on the power supply and current consumption.

(4) The RTS_DE, TX, and RX signals of USART3, UART5 and UART8 can be mapped to any IO.

(5) The TX, and RX signals of FDCAN1, FDCAN2 and FDCAN3 can be mapped to any IO.

The ADC12_INx mentioned in the pin name annotations in the table indicates that this pin can be either ADC1_INx or ADC2_INx. For example, ADC12_IN9 means that this pin can be configured as ADC1_IN9 or ADC2_IN9.

Similarly, the ADC34_INx mentioned in the pin name annotations in the table indicates that this pin can be either ADC3_INx or ADC4_INx.

In the pin PA0 of the table, the multiplexing function GTIM1_CH1_ETR means that this function can be configured as GTIM1_TII or GTIM1_ETR. Similarly, for PA15, the remapping multiplexing function name GTIM1_CH1_ETR has the same meaning.

For the FT ports in the table, it is necessary to ensure that the voltage difference between the IO voltage and the power supply voltage is less than 3.6V.

4 Electrical Characteristics

4.1 Parameter Conditions

All voltages are based on V_{SS} unless otherwise specified.

4.1.1 Minimum and Maximum Values

The minimum and maximum values in the Beta version are based on design simulations.

Note at the bottom of each form that data obtained through comprehensive evaluation, design simulation and/or process characteristics will not be tested on the production; Base on comprehensive evaluation, the minimum and maximum values are obtained by taking the average of the samples tested and adding or subtracting three times the standard distribution (mean $\pm 3\sigma$).

4.1.2 Typical Values

Unless otherwise specified, typical data are based on $T_A = 25\text{ }^\circ\text{C}$ and $V_{DD} = 3.3\text{V}$ (for the $1.8\text{V} \leq V_{DD} \leq 3.6\text{V}$ voltage range). These data are for design guidance only and not tested.

4.1.3 Typical Curves

Unless otherwise specified, typical curves are for design guidance only and not tested.

4.1.4 Loading Capacitor

The load conditions for measuring pin parameters are shown Figure 4-1:

Figure 4-1 Load Conditions Of Pins

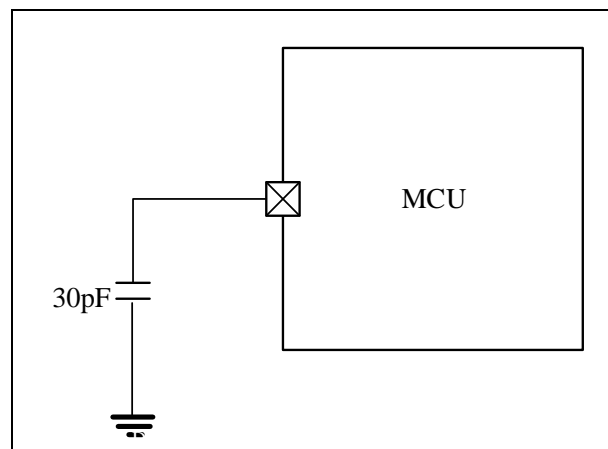

4.1.5 Pin Input Voltage

The measurement of the input voltage on the pin is shown Figure 4-2:

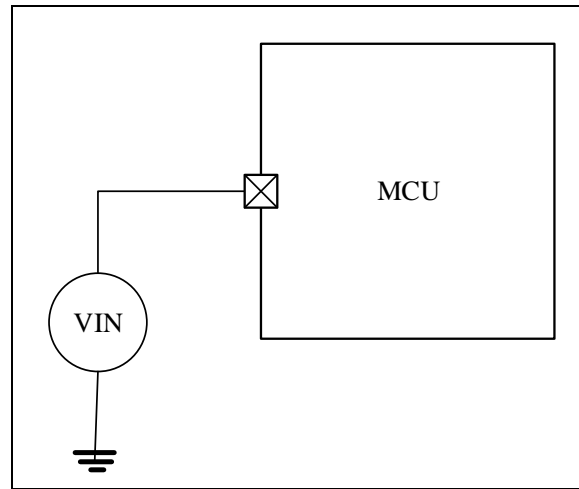
Figure 4-2 Pin Input Voltage

4.1.6 Power Supply Scheme

Figure 4-3 Power Supply Scheme

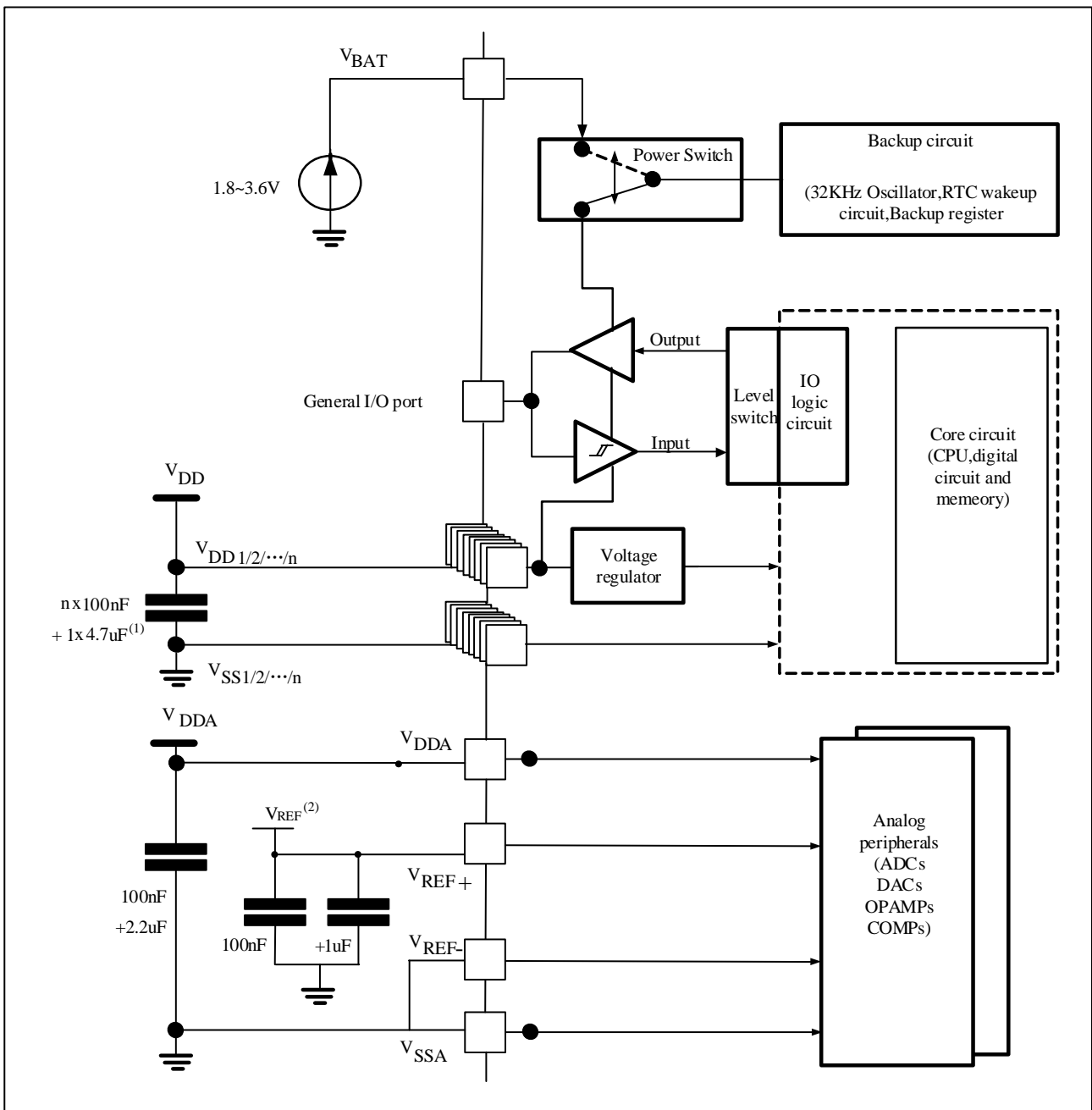

Notes:

(1) The $4.7\mu\text{F}$ capacitor in the above diagram must be connected to the specified VDD. The specified VDD for QFN32 is Pin 1, for UQFN48 and LQFP48 is Pin 48, for LQFP64 is Pin 64, for LQFP80 is Pin 80, for LQFP100 is Pin 100, and for LQFP128 is Pin 128.

(2) The figure above shows the application scenario of VREF output. When VREF is selected for external connection, the $1\mu\text{F}$ capacitor needs to be changed to a $2.2\mu\text{F}$ capacitor.

4.1.7 Current Consumption Measurement

Figure 4-4 Current Consumption Measurement Scheme

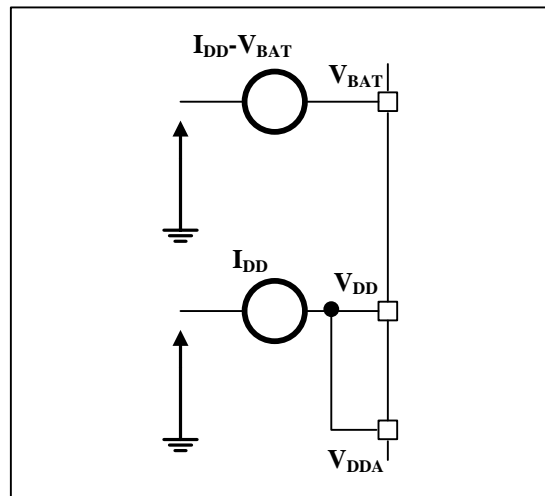

4.2 Absolute Maximum Rating

The load applied to the device may permanently damage the device if it exceeds the values given in the Absolute maximum rating list (Table 4-1, Table 4-2, Table 4-3). The maximum load that can be sustained is only given here, and it does not mean that the functional operation of the device under such conditions is correct. The reliability of the device will be affected when the device works for a long time under the maximum condition.

Table 4-1 Voltage Characteristics

Symbol	Describe	Min	Max	Unit
$V_{DD} - V_{SS}$	External main supply voltage (including V_{DDA} and V_{DD}) ⁽¹⁾	-0.3	4.0	V
V_{IN}	Input voltage on 5V tolerant pins ⁽³⁾	$V_{SS}-0.3$	5.5	
	Input voltage on other pins ⁽²⁾	$V_{SS}-0.3$	$V_{DD} + 0.3$	
$ \Delta V_{DDx} $	Voltage difference between different supply pins	-	50	mV
$ V_{SSx} - V_{SS} $	Voltage difference between different ground pins	-	50	
$V_{ESD(HBM)}$	ESD Electrostatic discharge voltage (human body model)	See section 4.3.11		-

Notes:

(1) All power (V_{DD} , V_{DDA}) and ground (V_{SS} , V_{SSA}) pins must always be connected to the external power supply system within permissible limits.

(2) V_{IN} shall not exceed its maximum value. Refer to Table 4-2 for current characteristics.

(3) When a 5V tolerant pin inputs 5.5V, V_{DD} cannot be lower than 2.25V.

Table 4-2 Current Characteristics

Symbol	Describe	Max ⁽¹⁾	Unit
I_{VDD}	Total current through V_{DD}/V_{DDA} power line (supply current) ⁽¹⁾⁽⁴⁾	400	mA
I_{VSS}	Total current through V_{SS} ground line (outflow current) ⁽¹⁾⁽⁴⁾	400	
I_{IO}	Output current sunk by I/O and control pins	12	
	Output current source by I/O and control pins	-12	

$I_{INJ(PIN)}^{(2)(3)}$	Injection current on NRST pin	-5/0
	Injection current on other pins	+/-5

Notes:

(1) All power (V_{DD} , V_{DDA}) and ground (V_{SS} , V_{SSA}) pins must always be connected to the external power supply system within permissible limits.

(2) When $V_{IN} > V_{DD}$, there is a forward injection current; when $V_{IN} < V_{SS}$, there is a reverse injection current. $I_{INJ(PIN)}$ should not exceed its maximum value. Refer to Table 4-1 for voltage characteristics.

(3) Reverse injection current can interfere with the analog performance of the device. See section 4.3.2323.

(4) When the maximum current occurs, the maximum allowable voltage drop of V_{DD} is $0.1V_{DD}$.

Table 4-3 Temperature Characteristics

Symbol	Describe	Value	Unit
T_{STG}	Storage temperature range	- 65 ~ + 150	°C
T_J	Maximum junction temperature, The temperature scale is 7	125	°C
	Maximum junction temperature, The temperature scale is 8	140	°C

4.3 Operating Conditions

4.3.1 General Operating Conditions

Table 4-4 General Operating Conditions

Symbol	Parameter	Condition	Min	Max	Unit
f_{HCLK}	Internal AHB clock frequency	-	0	240	MHz
f_{PCLK}	Internal APB1/2 clock frequency	-	0	180	
V_{DDA}	Analog operating of working voltage	Must be the same potential as $V_{DD}^{(1)}$	1.8	3.6	V
V_{BAT}	Backup domain supply voltage		1.8	3.6	V
T_A	Ambient temperature	suffix 7 version	-40	105	°C
		suffix 8 version	-40	125	
T_J	Junction temperature range	suffix 7 version	-40	125	°C
		suffix 8 version	-40	140	

Note: (1) It is recommended that the same power supply be used to power the V_{DD} and V_{DDA} . During power-on and normal operation, a maximum of 300mV difference is allowed between the V_{DD} and V_{DDA} .

4.3.2 Operating Conditions at Power-on and Power-off

The parameters given in the following table are based on the ambient temperatures listed in Table 4-4.

Table 4-5 Operating Conditions At Power-On And Power-Off

Symbol	Parameter	Condition	Min	Max	Unit
t_{VDD}	V_{DD} rise time rate	-	20	∞	$\mu s/V$
	V_{DD} fall time rate		80	∞	

4.3.3 Embedded Reset and Power Control Module Characteristics

The parameters given in the following table are based on the ambient temperature and V_{DD} supply voltage listed in

Table 4-4.

Table 4-6 Features Of Embedded Reset And Power Control Modules

Symbol	Parameter	Conditions	Min	Typ	Max	Unit
V_{PVD}	Programmable voltage detector level selection (MSB of PWR_CTRL is 0)	PRS[2:0]=000 (rising edge)	2.09	2.18	2.27	V
		PRS[2:0]=000 (falling edge)	2	2.08	2.16	V
		PRS[2:0]=001 (rising edge)	2.19	2.28	2.37	V
		PRS[2:0]=001 (falling edge)	2.09	2.18	2.27	V
		PRS[2:0]=010 (rising edge)	2.28	2.38	2.48	V
		PRS[2:0]=010 (falling edge)	2.19	2.28	2.37	V
		PRS[2:0]=011 (rising edge)	2.38	2.48	2.58	V
		PRS[2:0]=011 (falling edge)	2.28	2.38	2.48	V
		PRS[2:0]=100 (rising edge)	2.47	2.58	2.69	V
		PRS[2:0]=100 (falling edge)	2.37	2.48	2.59	V
		PRS[2:0]=101 (rising edge)	2.57	2.68	2.79	V
		PRS[2:0]=101 (falling edge)	2.47	2.58	2.69	V
		PRS[2:0]=110 (rising edge)	2.66	2.78	2.9	V
		PRS[2:0]=110 (falling edge)	2.56	2.68	2.8	V
		PRS[2:0]=111 (rising edge)	2.76	2.88	3	V
		PRS[2:0]=111 (falling edge)	2.66	2.78	2.9	V
	Programmable voltage detector level selection (MSB of PWR_CTRL is 1)	PRS[2:0]=000 (rising edge)	1.7	1.78	1.85	V
		PRS[2:0]=000 (falling edge)	1.61	1.68	1.75	V
		PRS[2:0]=001 (rising edge)	1.8	1.88	1.96	V
		PRS[2:0]=001 (falling edge)	1.7	1.78	1.85	V
		PRS[2:0]=010 (rising edge)	1.9	1.98	2.06	V
		PRS[2:0]=010 (falling edge)	1.8	1.88	1.96	V
		PRS[2:0]=011 (rising edge)	2	2.08	2.16	V
		PRS[2:0]=011 (falling edge)	1.9	1.98	2.06	V
		PRS[2:0]=100 (rising edge)	3.15	3.28	3.41	V
		PRS[2:0]=100 (falling edge)	3.05	3.18	3.31	V
		PRS[2:0]=101 (rising edge)	3.24	3.38	3.52	V
		PRS[2:0]=101 (falling edge)	3.15	3.28	3.41	V
		PRS[2:0]=110 (rising edge)	3.34	3.48	3.62	V
		PRS[2:0]=110 (falling edge)	3.24	3.38	3.52	V
		PRS[2:0]=111 (rising edge)	3.44	3.58	3.72	V
		PRS[2:0]=111 (falling edge)	3.34	3.48	3.62	V
$V_{PVDhyst}^{(1)}$	PVD hysteresis	-	-	100	-	mV
V_{POR}	VDD power on/power down reset threshold	-	-	1.66/1.58	-	V
V_{BOR}	BOR power on/off reset threshold	BOR_LVL[2:0]=000 (rising edge)	-	1.66	-	V
		BOR_LVL[2:0]=000 (falling edge)	-	1.62	-	V
		BOR_LVL[2:0]=001 (rising edge)	-	2.1	-	V
		BOR_LVL[2:0]=001 (falling edge)	-	2	-	V
		BOR_LVL[2:0]=010 (rising edge)	-	2.3	-	V

Symbol	Parameter	Conditions	Min	Typ	Max	Unit
		BOR_LVL[2:0]=010 (falling edge)	-	2.2	-	V
		BOR_LVL[2:0]=011 (rising edge)	-	2.6	-	V
		BOR_LVL[2:0]=011 (falling edge)	-	2.5	-	V
		BOR_LVL[2:0]=100 (rising edge)	-	2.9	-	V
		BOR_LVL[2:0]=100 (falling edge)	-	2.8	-	V
TRSTEMPO ⁽¹⁾	Reset duration	-	-	0.8	4	ms

Note: (1) Guaranteed by design, not tested in production.

4.3.4 Embedded Reference Voltage

The parameters given in the following table are based on the ambient temperature and V_{DD} supply voltage listed in Table 4-4.

Table 4-7 Internal Reference Voltage

Symbol	Parameter	Conditions	Min	Typ	Max	Unit
V_{REFINT}	Internal reference voltage	$-40^{\circ}\text{C} < T_A < +105^{\circ}\text{C}$	1.164	1.2	1.236	V
$T_{S_vrefint}^{(1)}$	The sampling time of the ADC when reading the internal reference voltage	-	-	5.1	17.1 ⁽²⁾	μs
ΔV_{REFINT}	Internal reference voltage spread over the temperature range	$V_{DD} = 3.3\text{V}$ $-40^{\circ}\text{C} < T_A < +105^{\circ}\text{C}$	-14	-	14	mV

Notes:

(1) The shortest sampling time is obtained through multiple loops in the application.

(2) Guaranteed by design, not tested in production.

4.3.5 Power Supply Current Characteristics

The current consumption is a combination of several parameters and factors, including operating voltage, ambient temperature, load of I/O pins, software configuration of the product, operating frequency, toggle rate of I/O pins, program location in memory, and executed code.

The measurement method of current consumption is described in Figure 4-4.

All of the current consumption measurements given in this section are while executing a reduced set of code.

4.3.5.1 Maximum Current Consumption

The device is under the following conditions:

- All I/O pins are in input mode and are connected to a static level -- V_{DD} or V_{SS} (no load).
- All peripherals are disabled except otherwise noted.
- The access time of the flash memory is adjusted to the fastest operating frequency (0 waiting period from 0 to 40 MHz, 1 waiting period from 40 to 80 MHz, 2 waiting periods from 80 to 120 MHz, 3 waiting periods from 120 to 160 MHz, 4 waiting periods from 160 to 200 MHz, 5 waiting periods from 200 to 240 MHz).
- Instruction prefetch is enabled (note: this parameter must be set before setting the clock and bus divider).
- When the peripheral is enable: $f_{PCLK1} = f_{HCLK}/2$, $f_{PCLK2} = f_{HCLK}/2$.
- V_{DD} is 3.63V, ambient temperature is $105^{\circ}\text{C}/125^{\circ}\text{C}$

The parameters given in Table 4-8 and Table 4-9 are based on tests at the ambient temperature and V_{DD} supply voltage listed in Table 4-4.

Table 4-8 Maximum Current Consumption In Operating Mode Where Data Processing Code Is Run From Internal Flash

Symbol	Parameter	Condition	f _{HCLK}	Typ ⁽¹⁾					Unit
				T _A = -40°C	T _A = 25°C	T _A = 85°C	T _A = 105°C	T _A = 125°C	
I _{DD}	Supply current in operation mode	External clock ⁽²⁾ , enable all peripherals	240MHz	106.29	109.42	122.36	133.59	152.10	mA
			200MHz	87.34	90.33	103.48	113.97	129.83	
			180MHz	80.64	83.54	96.45	106.85	122.57	
			150MHz	75.16	77.99	90.68	100.94	116.56	
			100MHz	52.45	55.01	67.00	76.91	92.00	
			50MHz	29.63	31.92	43.39	52.96	67.73	
		External clock ⁽²⁾ , disable all peripherals	240MHz	31.21	33.86	45.19	54.81	69.33	
			200MHz	26.63	29.14	40.25	49.78	64.26	
			180MHz	24.73	27.23	38.20	47.72	62.13	
			150MHz	22.65	25.04	35.90	45.38	59.70	
			100MHz	16.46	18.72	29.16	38.41	52.25	
			50MHz	10.13	12.28	22.92	32.15	46.27	

Notes:

(1) Based on comprehensive evaluation, not tested in production.

(2) Enable PLL when f_{HCLK} > 8MHz.

Table 4-9 Maximum Current Consumption In Sleep Mode, Code Running In Internal Flash Running

Symbol	Parameter	Conditions	f _{HCLK}	Typ ⁽¹⁾					Unit
				T _A = -40°C	T _A = 25°C	T _A = 85°C	T _A = 105°C	T _A = 125°C	
I _{DD}	Supply current in sleep mode	External clock ⁽²⁾ , enable all peripherals	240MHz	96.70	99.77	111.57	123.13	141.52	mA
			200MHz	79.66	82.50	95.33	105.64	121.39	
			180MHz	73.56	76.32	88.98	99.13	114.77	
			150MHz	69.08	71.76	84.23	94.32	109.80	
			100MHz	48.27	50.73	62.60	72.40	87.46	
			50MHz	27.43	29.65	41.05	50.52	65.23	
		External clock ⁽²⁾ , disable all peripherals	240MHz	19.26	21.48	32.59	41.85	56.35	
			200MHz	16.53	18.71	29.72	38.98	53.34	
			180MHz	15.45	17.61	28.59	37.81	52.15	
			150MHz	13.95	16.09	27.00	36.22	50.49	
			100MHz	10.50	12.59	23.42	32.59	46.83	
			50MHz	7.05	9.08	19.81	28.85	43.06	

Notes:

(1) Based on comprehensive evaluation result, not tested in production.

(2) Enable PLL when f_{HCLK} > 8MHz.

4.3.5.2 Current consumption in Low-Power Mode

MCU is under the following conditions:

- All I/O pins are in input mode and are connected to a static level -- V_{DD} or V_{SS} (no load).
- All peripherals are disable unless otherwise noted.

Table 4-10 Typical Current Consumption In Low Power Mode⁽²⁾

Symbol	Parameter	Conditions	Typ ⁽¹⁾					Unit
			T _A = -40°C	T _A = 25°C	T _A = 85°C	T _A = 105°C	T _A = 125°C	
I _{DD}	Supply current in STOP0 mode	Regulator in run mode, LSE on, RTC on, IWDG off, Backup SRAM hold	1.30	2.84	13.00	21.84	35.59	mA
		Regulator in LP mode, LSE on, RTC on, IWDG off, Backup SRAM hold	0.87	1.67	7.72	13.24	22.15	
I _{DD}	Supply current in STANDBY mode ⁽²⁾	LSE on, RTC on, IWDG off, BackupSRAM hold	17.4	18.7	29.4	44.0	70.2	uA
		LSE on, RTC off, IWDG off, BackupSRAM hold	17.3	18.6	29.3	44.0	70.8	
		LSE on, RTC off, IWDG off, BackupSRAM not holding	17.3	18.6	29.4	44.1	71.4	
I _{DD_VBAT}	Supply current in VBAT mode	LSE on, RTC on, IWDG off, Backup SRAM hold	2.6	3.8	10.9	19.8	34.4	uA

Note: (1)Based on comprehensive evaluation result, not tested in production.

(2) Based on the results of Version B chip test

Table 4-11 Typical Current Consumption In Low Power Mode⁽²⁾

Symbol	Parameter	Conditions	Typ ⁽¹⁾					Unit
			T _A = -40°C	T _A = 25°C	T _A = 85°C	T _A = 105°C	T _A = 125°C	
I _{DD}	Supply current in STOP0 mode	Regulator in run mode, LSE on, RTC on, IWDG off, Backup SRAM hold	1.30	2.84	13.00	21.84	35.59	mA
		Regulator in LP mode, LSE on, RTC on, IWDG off, Backup SRAM hold	0.87	1.67	7.72	13.24	22.15	
I _{DD}	Supply current in STANDBY mode ⁽²⁾	LSE on, RTC on, IWDG off, BackupSRAM hold	2.8	3.9	16.3	31.3	56.8	uA
		LSE on, RTC off, IWDG off, BackupSRAM hold	2.7	3.8	16.2	31.4	57.7	
		LSE on, RTC off, IWDG off, BackupSRAM do not hold	2.6	3.7	16.2	31.4	58.6	
I _{DD_VBAT}	Supply current in VBAT mode	LSE on, RTC on, IWDG off, Backup SRAM hold	2.6	3.6	12.3	22.4	39.4	uA

Note: (1)Based on comprehensive evaluation result, not tested in production.

(2) Based on the results of Version C chip test

4.3.5.3 Peripheral current consumption

Table 4-12 Peripheral current consumption

Bus	Peripheral	Typ	Unit
AHB	DMA1	4.47	
	DMA2	4.12	
	FEMC	15.44	
	XSPI	14.45	
AHB1	BKP SRAM	0.41	μA/MHz
	CORDIC	3.55	
	FMAC	6.93	
	CRC	0.83	
AHB2	SHRTIM1	20.02	μA/MHz
	ATIM1	10.17	
	ATIM2	10.82	
	ATIM3	10.69	
AHB3	GPIOA	45.33	μA/MHz
	GPIOB	45.82	
	GPIOC	46.06	
	GPIOD	44.89	
	GPIOE	45.41	
	GPIOF	45.81	
	GPIOG	44.98	
	GPIOH	44.52	
	ADC1	17.54	
	ADC2	14.06	
	ADC3	14.90	
	ADC4	14.66	
	DAC5	0.37	
	DAC6	0.37	
	DAC7	0.42	
	DAC8	0.42	
	SAC	2.49	
APB1	DAC1	4.64	μA/MHz
	DAC2	4.64	
	DAC3	4.75	
	DAC4	4.75	
	I2C1	6.40	
	I2C2	6.80	
	I2C3	6.77	

	I2C4	6.40	
	LPTIM1	3.91	
	LPTIM2	4.83	
	UART5	5.39	
	UART8	5.53	
	GTIM1	9.61	
	GTIM2	8.85	
	GTIM3	9.38	
	GTIM4	11.60	
	GTIM5	11.47	
	GTIM6	11.61	
	GTIM7	11.65	
	CANFD1	16.92	
	CANFD2	16.69	
	USBFS	8.48	
	BTIM1	6.56	
	BTIM2	6.38	
	SPI2/I2S2	6.64	
	SPI3/I2S3	6.48	
	USART2	6.62	
	USART3	6.85	
	RTC	3.26	
	WWDG	3.70	
	PWR	4.60	
	PGA1	3.51	
	PGA2	3.51	
	PGA3	3.51	
	PGA4	3.51	
	COMP1	3.61	
	COMP2	3.61	
	COMP3	3.61	
	COMP4	3.61	
	COMP5	3.61	
	COMP6	3.61	
	COMP7	3.61	
	SPI1	5.14	
	SPI4	5.28	
	SPI5	4.77	
	SPI6	4.82	
	USART1	6.83	
APB2			μA/MHz

	USART4	9.17	
	UART6	5.51	
	UART7	5.51	
	GTIM8	13.50	
	GTIM9	13.36	
	GTIM10	13.62	

4.3.6 External Clock Source Characteristics

4.3.6.1 High-Speed External Clock Source (HSE)

The characteristic parameters given in the following table are measured using a high-speed external clock source (Bypass mode), and the ambient temperature and supply voltage meet the conditions specified in **Table 4-4**.

Table 4-13 High-Speed External User Clock Features(Bypass Mode)

Symbol	Parameter	Conditions	Min	Typ	Max	Unit
f _{HSE_ext}	User external clock frequency ⁽¹⁾		1	8	50	MHz
V _{HSEH}	OSC_IN Input pin high level voltage		0.7V _{DD}	-	V _{DD}	V
V _{HSEL}	OSC_IN Input pin low level voltage		V _{SS}	-	0.3V _{DD}	
t _{w(HSE)}	Time when OSC_IN is high or low ⁽¹⁾		16	-	-	ns
t _{r(HSE)}	OSC_IN rise or fall time ⁽¹⁾		-	-	20	
t _{f(HSE)}						
DuCy _(HSE)	Duty cycle	-	45	-	55	%
I _L	OSC_IN Input leakage current	V _{SS} ≤ V _{IN} ≤ V _{DD}	-1	-	+1	μA

Note: (1) Guaranteed by design, not tested in production.

4.3.6.2 Low-Speed External Clock Source (LSE)

The characteristic parameters given in the following table are measured using a low speed external clock source (Bypass mode), and the ambient temperature and supply voltage meet the conditions specified in **Table 4-4**.

Table 4-14 Features Of A Low-Speed External User Clock(Bypass Mode)

Symbol	Parameter	Conditions	Min	Typ	Max	Unit
f _{LSE_ext}	User external clock frequency ⁽¹⁾		8.8	32.768	1000	KHz
V _{LSEH}	OSC32_IN Input pin high level voltage		0.7V _{DD}	-	V _{DD}	V
V _{LSEL}	OSC32_IN Input pin low level voltage		V _{SS}	-	0.3V _{DD}	mV
t _{w(LSE)}	OSC32_IN High or low time ⁽¹⁾		450	-	-	ns
t _{f(LSE)}						
t _{r(LSE)}	OSC32_IN Rise or fall time ⁽¹⁾		-	-	50	

Symbol	Parameter	Conditions	Min	Typ	Max	Unit
$t_{f(LSE)}$	Duty ratio		30	-	70	%
$DuCy_{(LSE)}$						
I_L	OSC32_IN Input leakage current	$V_{SS} \leq V_{IN} \leq V_{DD}$	-	-	± 1	μA

Note: (1) Guaranteed by design, not tested in production.

Figure 4-5 AC Timing Diagram Of An External High Speed Clock Source

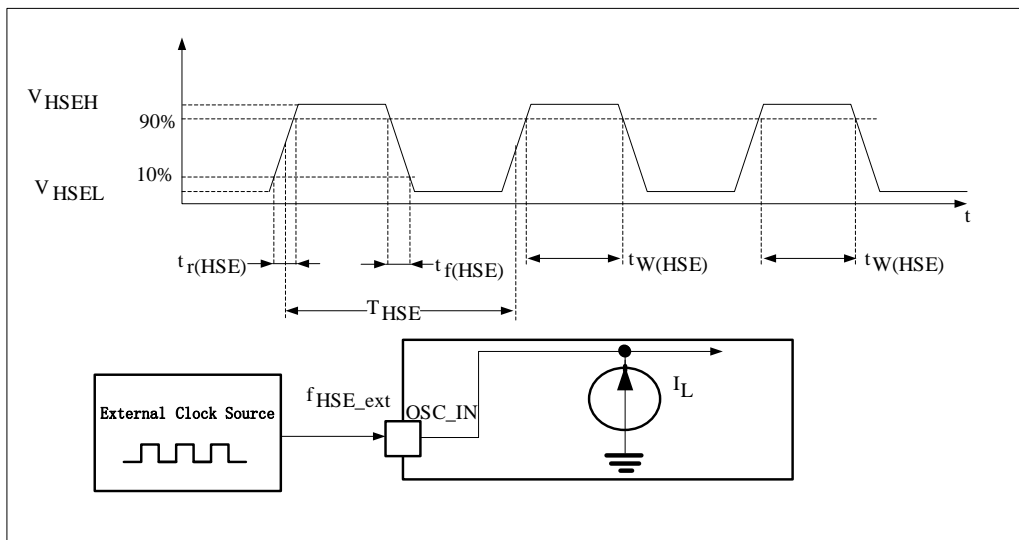
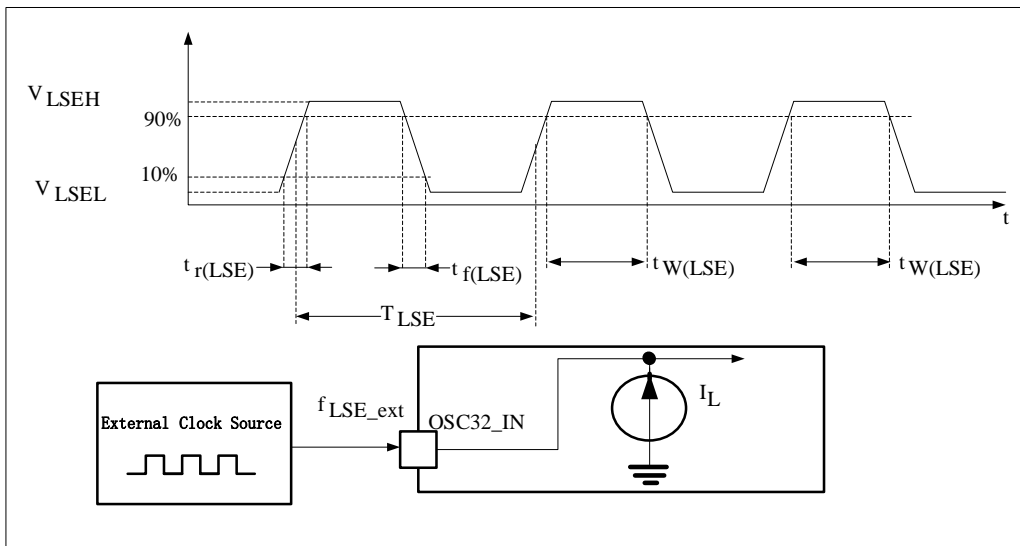

Figure 4-6 AC Timing Diagram Of An External Low Speed Clock Source



High-speed external clock generated using a crystal/ceramic resonator

High speed external clocks (HSE) can be generated using an oscillator consisting of a 4~32MHz crystal/ceramic resonator. The information presented in this section is based on a comprehensive feature evaluation using typical external components listed in the table below. In applications, the resonator and load capacitance must be as close to the oscillator pins as possible to reduce output distortion and stabilization time at startup. For detailed crystal resonator parameters (frequency, package, accuracy, etc.), please consult the appropriate manufacturer. (The crystal resonator mentioned here is usually referred to as passive crystal oscillator)

Table 4-15 HSE 4~32MHz Oscillator Characteristics ^{(1) (2)}

Symbol	Parameter	Conditions	Min	Typ	Max	Unit
f_{OSC_IN}	Oscillator frequency	-	4	8	32	MHz
R_F	Feedback resistance	-	-	380	-	k Ω
i_2	HSE drive current	$V_{DD} = 3.3V$, $V_{IN} = V_{SS}$ 30 pf load	-	1.8	-	mA
g_m	Transconductance of the oscillator	Start	-	10	-	mA/V
$t_{SU(HSE)}^{(3)}$	Startup time (8M crystal)	V_{DD} is stabilized	-	3	5	ms

Notes:

(1) The characteristic parameters of the resonator are given by the crystal/ceramic resonator manufacturer.

(2) Guaranteed by characterization results, not tested in production.

(3) $t_{SU(HSE)}$ is the start time, from the time when HSE is enabled by the software to the time when a stable 8MHz oscillation is obtained. This value is measured on a standard crystal resonator and can vary widely depending on the crystal manufacturer.

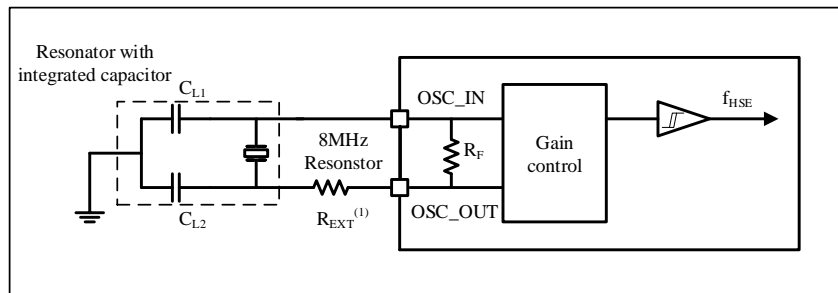
Figure 4-7 Typical Application Using 8 MHz Crystal

Note: (1) The R_{EXT} value depends on the properties of the crystal.

Low-speed external clock generated by a crystal/ceramic resonator

The low speed external clock (LSE) can be generated using an oscillator consisting of a 32.768 kHz crystal/ceramic resonator. The information presented in this section is based on a comprehensive feature evaluation using typical external components. In applications, the resonator and load capacitance must be as close to the oscillator pins as possible to reduce output distortion and stabilization time at startup. For detailed crystal resonator parameters (frequency, package, accuracy, etc.), please consult the appropriate manufacturer. (The crystal resonator mentioned here is usually referred to as passive crystal oscillator)

Note: For C_{L1} and C_{L2} , it is recommended to use high quality ceramic dielectric containers, and to select crystals or resonators that meet the requirements. Usually C_{L1} and C_{L2} have the same parameters. Crystal manufacturers usually give parameters for load capacitance as serial combinations of C_{L1} and C_{L2} .

Load capacitance C_L is calculated by the following formula: $C_L = C_{L1} \times C_{L2} / (C_{L1} + C_{L2}) + C_{stray}$, where C_{stray} is the capacitance of the pin and the PCB or PCB-related capacitance.

For example: If a resonator with load capacitance $C_L = 6pF$ is selected and $C_{stray} = 2pF$, then $C_{L1} = C_{L2} = 8pF$.

Table 4-16 LSE Oscillator Characteristics ($F_{LSE} = 32.768KHz$) ⁽¹⁾

Symbol	Parameter	Conditions	Min	Typ	Max	Unit
R_F	Feedback resistor	-	-	5	-	M Ω
I_2	LSE drive current	Low drive capability	-	300	-	nA
		Medium low drive capability	-	750	-	
		High drive capability	-	1000	-	

g_m	Maximum transconductance	Low drive capability	-	9	-	$\mu\text{A/V}$
		Medium low drive capability	-	12	-	
		High drive capability	-	27	-	
$t_{\text{SU(LSE)}}^{(2)}$	Startup time	V_{DD} is stabilized	-	2	-	s

Notes:

(1) Guaranteed by design, not tested in production.

(2) $t_{\text{SU(LSE)}}$ is the starting time, which is the period from the LSE enabled by the software to the stable 32.768 kHz oscillation. This value is measured on a standard crystal resonator and can vary widely depending on the crystal manufacturer.

Figure 4-8 Typical Application Of 32.768KHz Crystal

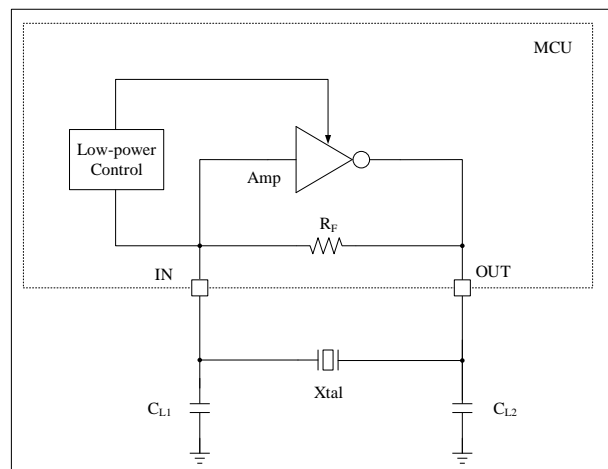

4.3.7 Internal Clock Source Characteristics

The characteristic parameters given in the following table were measured using ambient temperature and supply voltage in accordance with Table 4-4.

4.3.7.1 High Speed Internal (HSI) RC Oscillator

Table 4-17 HSI Oscillator Characteristics ^{(1) (2)}

Symbol	Parameter	Condition	Min	Typ	Max	Unit
f_{HSI}	frequency	$V_{\text{DD}}=3.3\text{V}$, $T_A = 25^\circ\text{C}$, after calibration	7.96 ⁽³⁾	8	8.04 ⁽³⁾	MHz
ACC_{HSI}	Temperature drift of HSI oscillator	$V_{\text{DD}}=3.3\text{V}$, $T_A = -40\sim 125^\circ\text{C}$	-1.5	-	2	%
		$V_{\text{DD}}=3.3\text{V}$, $T_A = -40\sim 105^\circ\text{C}$	-1.2	-	2	%
		$V_{\text{DD}}=3.3\text{V}$, $T_A = -10\sim 85^\circ\text{C}$	-0.8	-	1.5	%
		$V_{\text{DD}}=3.3\text{V}$, $T_A = 0\sim 70^\circ\text{C}$	-0.5	-	1.3	%
$t_{\text{SU(HSI)}}$	HSI oscillator start time	-	-	-	6	μs
$I_{\text{DD(HSI)}}$	HSI oscillator power consumption	-	-	100	120	μA

Notes:

(1) $V_{\text{DD}} = 3.3\text{V}$, $T_A = -40\sim 125^\circ\text{C}$ unless otherwise specified.

(2) Guaranteed by design, not tested in production.

(3) Production calibration accuracy, excluding soldering effects. Soldering introduces a frequency deviation range of approximately

$\pm 1\%$

(4) Frequency deviation includes the effects of soldering, data is from sample testing, not tested in production.

4.3.7.2 Low Speed Internal (LSI) RC Oscillator

Table 4-18 LSI Oscillator Characteristics ⁽¹⁾

Symbol	Parameter	Condition	Min	Typ	Max	Unit
$f_{LSI}^{(2)}$	Output frequency	25°C calibration, $V_{DD} = 3.3V$	-	32	-	KHz
		$V_{DD} = 1.8V$ to $3.6V$, $T_A = -40 \sim 105^\circ C$	28.8	32	35.2	KHz
$t_{SU(LSI)}^{(2)}$	LSI oscillator startup time	-	-	60	84	μs
$I_{DD(LSI)}^{(2)}$	LSI oscillator power consumption	-	-	0.6	-	μA

Notes:

(1) $V_{DD} = 3.3V$, $T_A = -40 \sim 105^\circ C$ unless otherwise specified.

(2) Guaranteed by characterization results, not tested in production.

4.3.8 Wake Up Time from Low Power Mode

The wake-up time listed in **Table 4-19** is measured during the wake-up phase of an 8MHz HSI RC oscillator. The clock source used when waking up depends on the current operating mode:

- STOP0 or STANDBY mode: clock source is RC oscillator
- SLEEP mode: The clock source is the clock used to enter SLEEP mode

All times were measured using ambient temperature and supply voltage in accordance with **Table 4-4**.

Table 4-19 Wake Time In Low Power Mode

Symbol	Parameter	Typ ⁽¹⁾	Unit
twUSLEEP	Wake up from SLEEP mode	6	Cycles
twUSTOP0	Wake up from STOP0 mode (regulator in run mode)	20	μs
	Wake up from STOP0 mode (regulator in run mode)	22	μs
twUSTDBY	Wake up from STANDBY mode	100	μs

Note: (1) The wake up time is measured from the start of the wake up event until the first instruction is read by the user program.

4.3.9 PLL Characteristics

The parameters listed in **Table 4-20** are measured when the ambient temperature and power supply voltage meet the conditions in **Table 4-4**
Table 4-20 PLL Features

Symbol	Parameter	Value			Unit
		Min	Typ	Max ⁽¹⁾	
f_{PLL_IN}	PLL PFD input clock ⁽²⁾	4	8	50	MHz
	PLL Input clock duty cycle	40	50	60	%
f_{PLL_OUT}	PLL output clock ⁽²⁾	32	-	200	MHz
t_{LOCK}	PLL Ready indicates signal output time ⁽³⁾	-	-	150	μs
Jitter	RMS cycle-to-cycle jitter @240MHz	-	5	-	ps

Symbol	Parameter	Value			Unit
		Min	Typ	Max ⁽¹⁾	
f _{VCO_OUT}	PLL VCO output	64	-	500	MHz
I _{PLL}	Operating Current of PLL @240MHz VCO frequency.	-	-	1500	uA

Notes:

(1) Based on comprehensive evaluation, not tested in production.

(2) The correct configuration coefficients need to be used so that the f_{PLL_OUT} is within the allowable range according to the PLL input clock frequency.

Table 4-21 SHRTPLL Features

Symbol	Parameter	Value			Unit
		Min	Typ	Max ⁽¹⁾	
f _{SHRTPLL_IN}	SHRTPLL input clock ⁽²⁾	4	8	50	MHz
	SHRTPLL Input clock duty cycle	40	50	60	%
f _{SHRTPLL_OUT}	SHRTPLL output clock ⁽²⁾	75 ⁽³⁾	-	250 ⁽³⁾	MHz
t _{LOCK}	SHRTPLL Ready indicates signal output time ⁽³⁾	10	62.5	125	μs
Jitter	RMS cycle-to-cycle jitter @250MHz	-	100	-	±ps
I _{SHRTPLL}	Operating Current of PLL @250MHz VCO frequency.	-	9.2	-	mA

Notes:

(1) Based on comprehensive evaluation, not tested in production.

(2) The correct configuration coefficients need to be used so that the f_{SHRTPLL_OUT} is within the allowable range according to the SHRTPLL input clock frequency.

(3) The actual SHRTPLL output is 300MHz~1000MHz, and when used by external devices, it will automatically divide by 4 internally.

4.3.10 FLASH Memory Characteristics

Unless otherwise specified, all characteristic parameters are obtained at T_A = -40~105°C.

Table 4-22 Flash Memory Characteristics

Symbol	Parameter	Condition	Min ⁽¹⁾	Typ ⁽¹⁾	Max ⁽¹⁾	Unit
t _{prog}	64-bit programming time	T _A = - 40 ~ 105 °C, double word mode	-	40	-	μs
		T _A = - 40 ~ 105 °C, buffer program mode	-	19	-	
t _{ERASE}	Page (8K bytes) erasure time	T _A = - 40 ~ 105 °C	-	10	20	ms
t _{ME}	Mass erase time	T _A = - 40 ~ 105 °C	-	10	20	ms
I _{DD}	The power supply current	Read mode, f _{HCLK} = 240 MHz, 4 waiting cycles, V _{DD} = 3.3V	-	4.2	5.45	mA
		Write mode, f _{HCLK} = 240 MHz, V _{DD} = 3.3V	-	6.5	-	mA
		Erase mode, f _{HCLK} = 240 MHz, V _{DD} = 3.3V	-	4.5	-	mA
		Power-down/stop mode, V _{DD} = 3.3~3.6V	-	0.05	4.65	μA
V _{prog}	Programming voltage	-	1.8	3	3.6	V

Note: (1) Guaranteed by design, not tested in production.

Table 4-23 Flash Endurance And Data Retention Life

Symbol	Parameter	Condition	Min ⁽¹⁾	Unit
N_{END}	Endurance (note: erasure times)	$T_A = -40 \sim 105 \text{ }^\circ\text{C}$, Flash size is 512 KB	10	Kcycle
t_{RET}	Data retention period	10kcycle ⁽²⁾ at $T_A = 85 \text{ }^\circ\text{C}$	20	Years
		10kcycle ⁽²⁾ at $T_A = 105 \text{ }^\circ\text{C}$	15	
		10kcycle ⁽²⁾ at $T_A = 125 \text{ }^\circ\text{C}$	10	

Note: (1) Based on comprehensive evaluation, not tested in production.

4.3.11 Absolute Maximum (Electrical Sensitivity)

Based on three different tests (ESD, ES, LU), a specific measurement method is used to test the strength of the chip to determine its performance in terms of electrical sensitivity.

Electrostatic discharge (ESD)

Electrostatic discharge (a positive pulse followed by a negative pulse one second later) is applied to all pins of all samples.

Table 4-24 Absolute Maximum ESD Value

Symbol	Parameter	Condition	Type	Max ⁽¹⁾	Unit
$V_{ESD(HBM)}^{(2)}$	Electrostatic discharge voltage (human body model)	$T_A = +25 \text{ }^\circ\text{C}$, In accordance with MIL-STD-883K Method 3015.9	3A	4000	V
$V_{ESD(CDM)}$	Electrostatic discharge voltage (charging device model)	$T_A = +25 \text{ }^\circ\text{C}$, In accordance with ESDA/JEDEC JS-002-2018	C3	1000	

Note: (1) Based on comprehensive evaluation, not tested in production.

(2) VBAT pin voltage maximum 2000V

Electromagnetic susceptibility (EMS)

Table 4-25 EMS Features

Symbol	Parameter	Condition	Level
V_{FESD}	Voltage limits to be applied on any I/O pin to induce a functional disturbance	$V_{DD} = 3.3\text{V}$, LQFP144, $T_A = 25 \text{ }^\circ\text{C}$, HCLK = 240MHz, conforms to IEC 61000-4-2	4A
V_{EFTB}	Fast transient voltage burst limits to be applied through 100 pF on VDD and VSS pins to induce a functional disturbance	$V_{DD} = 3.3\text{V}$, LQFP144, $T_A = 25 \text{ }^\circ\text{C}$, HCLK = 240MHz, conforms to IEC 61000-4-4	4A
	Fast transient voltage burst and capacitively coupled clamping limits to be applied on I/O pins to induce a functional disturbance	$V_{DD} = 3.3\text{V}$, LQFP144, $T_A = 25 \text{ }^\circ\text{C}$, HCLK = 240MHz, conforms to IEC 61000-4-4	4A

Static latch-up (LU)

To evaluate the locking performance, two complementary static locking tests were performed on six samples:

- Supply voltage exceeding limit for each power pin.
- Current is injected into each input, output, and configurable I/O pin.

This test conforms to EIA/JESD78A IC latch standard.

Table 4-26 Static Latch-Up

Symbol	Parameter	Condition	Type	Max ⁽¹⁾
--------	-----------	-----------	------	--------------------

LU	Static lock-up class	T _A = +125 °C, in accordance with JESD 78E	II class A	±200mA, 1.5*VDDMAX
----	----------------------	---	------------	--------------------

Note:(1) Tested on normal temperature conditions.

4.3.12 I/O Port Characteristics

General input/output characteristics

Unless otherwise specified, the parameters listed in the following table are measured according to the conditions in Table 4-4. All I/O ports are CMOS and TTL compatible.

Table 4-27 I/O Static Characteristics

Symbol	Parameter	Condition	Min ⁽¹⁾	Typ ⁽¹⁾	Max ⁽¹⁾	Unit
V _{IL}	Input low level voltage	V _{DD} =3.3V	V _{SS}	-	0.8	V
		V _{DD} =2.5V	V _{SS}	-	0.7	
		V _{DD} =1.8V	V _{SS}	-	0.3*V _{DD}	
V _{IH}	Input high level voltage	V _{DD} =3.3V	2	-	V _{DD}	V
		V _{DD} =2.5V	1.7	-	V _{DD}	
		V _{DD} =1.8V	0.7*V _{DD}	-	V _{DD}	
V _{hys}	Schmidt trigger voltage hysteresis ⁽¹⁾	V _{DD} =3.3V	200	-	-	mV
		V _{DD} =2.5V	200	-	-	
		V _{DD} =1.8V	0.1*V _{DD} ⁽²⁾	-	-	
I _{lkg}	Input leakage current ⁽³⁾	V _{DD} =Maximum	-1	-	1	μA
		V _{PAD} =0 or V _{PAD} =V _{DD} ⁽⁵⁾				
R _{PU}	Weak pull-up equivalent resistor ⁽⁴⁾	V _{DD} =3.3V, V _{IN} = V _{SS}	80	-	220	kΩ
		V _{DD} =1.8~3.3V, V _{IN} = V _{SS}	60	-	500	kΩ
R _{PD}	Weak pull-down equivalent resistor ⁽⁴⁾	V _{DD} =3.3V, V _{IN} = V _{DD}	80	-	220	kΩ
		V _{DD} =1.8~3.3V, V _{IN} = V _{DD}	60	-	500	kΩ
C _{IO}	I/O pin capacitance	-	-	5	-	pF

Notes:

(1) The hysteresis voltage of Schmitt trigger switching level. Based on comprehensive evaluation, not tested in production.

(2) At least 100mV.

(3) If there is reverse current injection from adjacent pins, the leakage current may be higher than the maximum value.

(4) Pull-up and pull-down resistors are implemented with a switchable PMOS/NMOS.

(5) V_{PAD} refers to the input voltage of the IO pin.

All I/O ports are CMOS and TTL compatible (no software configuration required) and their features take into account most of the strict CMOS process or TTL parameters:

Output driving current

GPIO (universal input/output port) can absorb or output up to +/-12mA current. In the user application, the number of I/O pins must ensure that the drive current does not exceed the absolute maximum ratings given in Section 4.2.

- The sum of the currents sourced by all the I/Os on V_{DD}, plus the maximum consumption of the MCU sourced on V_{DD}, cannot exceed the absolute maximum rating value I_{VDD} (Table 4-2)
- The sum of the currents sourced by all the I/Os on V_{SS}, plus the maximum consumption of the MCU sourced on V_{SS}, cannot exceed the absolute maximum rating value I_{VSS} (Table 4-2)

Output voltage

Unless otherwise specified, the parameters listed in **Table 4-29** were measured using ambient temperature and V_{DD} supply voltage in accordance with **Table 4-4**. All I/O ports are CMOS and TTL compatible

Table 4-28 IO Output Drive Capability Characteristics⁽¹⁾

Drive Capability	I_{OH} , $V_{DD}=3.3V$	I_{OL} , $V_{DD}=3.3V$	I_{OH} , $V_{DD}=2.5V$	I_{OL} , $V_{DD}=2.5V$	I_{OH} , $V_{DD}=1.8V$	I_{OL} , $V_{DD}=1.8V$	Unit
2	-2	2	-1.5	1.5	-1	1	mA
4	-4	4	-3	3	-2	2	mA
8	-8	8	-7	7	-5	5	mA
12	-12	12	-11	11	-7	8	mA

Note: (1) Guaranteed by design, not tested in production.

Table 4-29 Output Voltage Characteristics⁽³⁾

Symbol	Parameter	Condition	Min	Max	Unit
$V_{OL}^{(1)}$	Output low level	$V_{DD}=3.3V$, $I_{OL}^{(4)}=2/4/8/12$	V_{SS}	0.4	V
		$V_{DD}=2.5V$, $I_{OL}^{(4)}=2/4/8/12$	V_{SS}	0.4	
		$V_{DD}=1.8V$, $I_{OL}^{(4)}=2/4/8/12$	V_{SS}	$0.2 \cdot V_{DD}$	
$V_{OH}^{(2)}$	Output high level	$V_{DD}=3.3V$, $I_{OH}^{(4)}=2/4/8/12$	$2.4^{(5)}$	V_{DD}	
		$V_{DD}=2.5V$, $I_{OH}^{(4)}=2/4/8/12$	$1.8^{(5)}$	V_{DD}	
		$V_{DD}=1.8V$, $I_{OH}^{(4)}=2/4/8/12$	$0.8 \cdot V_{DD}$	V_{DD}	

Notes:

(1) The current I_{IO} absorbed by the chip must always follow the absolute maximum rating given in Table 4-2, and the sum of I_{IO} (all I/O pins and control pins) must not exceed I_{VSS} .

(2) The current I_{IO} output from the chip must always follow the absolute maximum rating given in Table 4-2, and the sum of I_{IO} (all I/O pins and control pins) must not exceed I_{VDD} .

(3) Data based on characterization results, not tested in production

(4) Actual drive capability see Table 4-28.

(5) PC13, PC14, PC15 are not within this range.

Input/output AC characteristics

The definitions and values of the input and output AC characteristics are given in **Figure 4-9** and **Table 4-30** respectively.

Unless otherwise specified, the parameters listed in **Table 4-30** were measured using ambient temperature and supply voltage in accordance with **Table 4-4**.

Table 4-30 Input/Output AC Characteristics⁽¹⁾

DSy[1:0] Configuration	Symbol	Parameter	Condition	Min	Max	Unit
00 (2mA)	$f_{\max(IO)out}$	Maximum frequency ⁽²⁾	$C_L=5pF, V_{DD}=3.3V$	-	75	MHz
			$C_L=5pF, V_{DD}=2.5V$	-	50	
			$C_L=5pF, V_{DD}=1.8V$	-	30	
	$t_{(IO)out}$	Output delay	$C_L=5pF, V_{DD}=3.3V$	-	3.7	ns
			$C_L=5pF, V_{DD}=2.5V$	-	4.8	
			$C_L=5pF, V_{DD}=1.8V$	-	7.2	
$t_{(IO)in}$	Input delay	$C_L=50fF, V_{DD}=2.97V, V_{DDD}=0.81V$ input characteristics at 1.8V and 2.5V are derated	-	2	ns	
10 (4mA)	$f_{\max(IO)out}$	Maximum frequency ⁽²⁾	$C_L=10pF, V_{DD}=3.3V$	-	90	MHz
			$C_L=10pF, V_{DD}=2.5V$	-	60	
			$C_L=10pF, V_{DD}=1.8V$	-	40	
	$t_{(IO)out}$	Output delay	$C_L=10pF, V_{DD}=3.3V$	-	3.5	ns
			$C_L=10pF, V_{DD}=2.5V$	-	4.5	
			$C_L=10pF, V_{DD}=1.8V$	-	-	

DSy[1:0] Configuration	Symbol	Parameter	Condition	Min	Max	Unit
01 (8mA)	$t_{(IO)in}$	Input delay	$C_L=10pF, V_{DD}=1.8V$	-	6.8	
			$CL=50fF, VDD=2.97V, VDDD=0.81V$ input characteristics at 1.8V and 2.5V are derated	-	2	
	$f_{max(IO)out}$	Maximum frequency ⁽²⁾	$C_L=20pF, V_{DD}=3.3V$	-	100	MHz
			$C_L=20pF, V_{DD}=2.5V$	-	75	
			$C_L=20pF, V_{DD}=1.8V$	-	50	
	$t_{(IO)out}$	Output delay	$C_L=20pF, V_{DD}=3.3V$	-	3.5	ns
$C_L=20pF, V_{DD}=2.5V$			-	4.8		
$C_L=20pF, V_{DD}=1.8V$			-	6.6		
$t_{(IO)in}$	Input delay	$CL=50fF, VDD=2.97V, VDDD=0.81V$ input characteristics at 1.8V and 2.5V are derated	-	2		
11 (12mA)	$f_{max(IO)out}$	Maximum frequency ⁽²⁾	$C_L=30pF, V_{DD}=3.3V$	-	120	MHz
			$C_L=30pF, V_{DD}=2.5V$	-	90	
			$C_L=30pF, V_{DD}=1.8V$	-	60	
	$t_{(IO)out}$	Output delay	$C_L=30pF, V_{DD}=3.3V$	-	3.4	ns
			$C_L=30pF, V_{DD}=2.5V$	-	4.3	
			$C_L=30pF, V_{DD}=1.8V$	-	6.4	
	$t_{(IO)in}$	Input delay	$CL=50fF, VDD=2.97V, VDDD=0.81V$ input characteristics at 1.8V and 2.5V are derated	-	2	

Notes:

(1) The speed of the I/O port can be configured via PMODEy [1:0]. Refer to the N32H474 user manual for instructions on configuring registers for GPIO ports.

(2) The maximum frequency is defined in Figure 4-9.

Figure 4-9 Definition Of Input/Output AC Characteristics

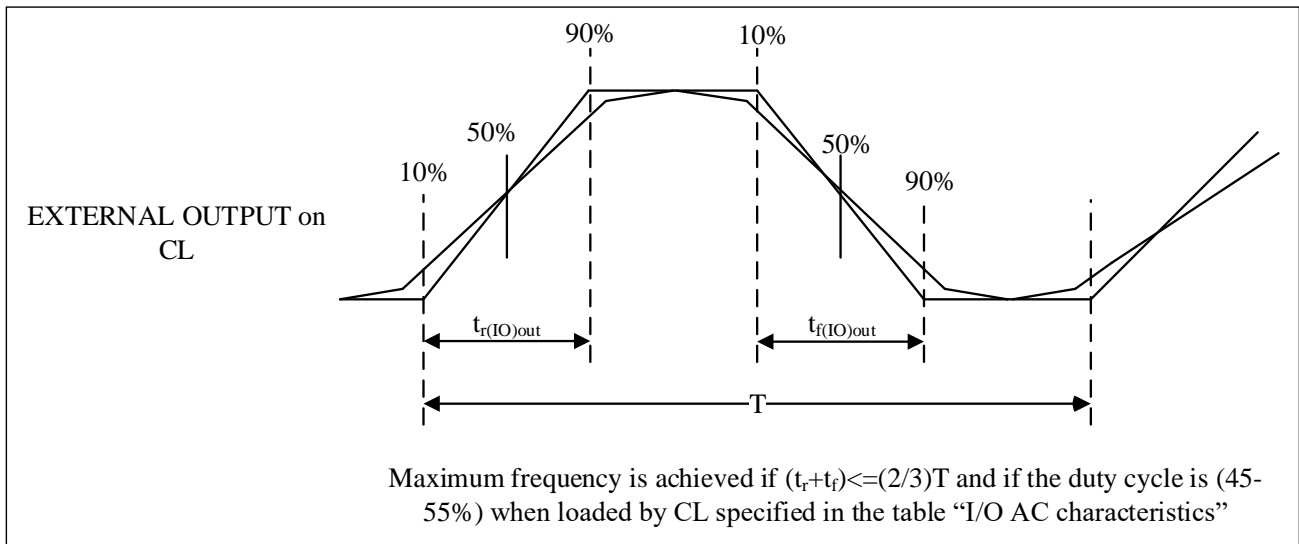
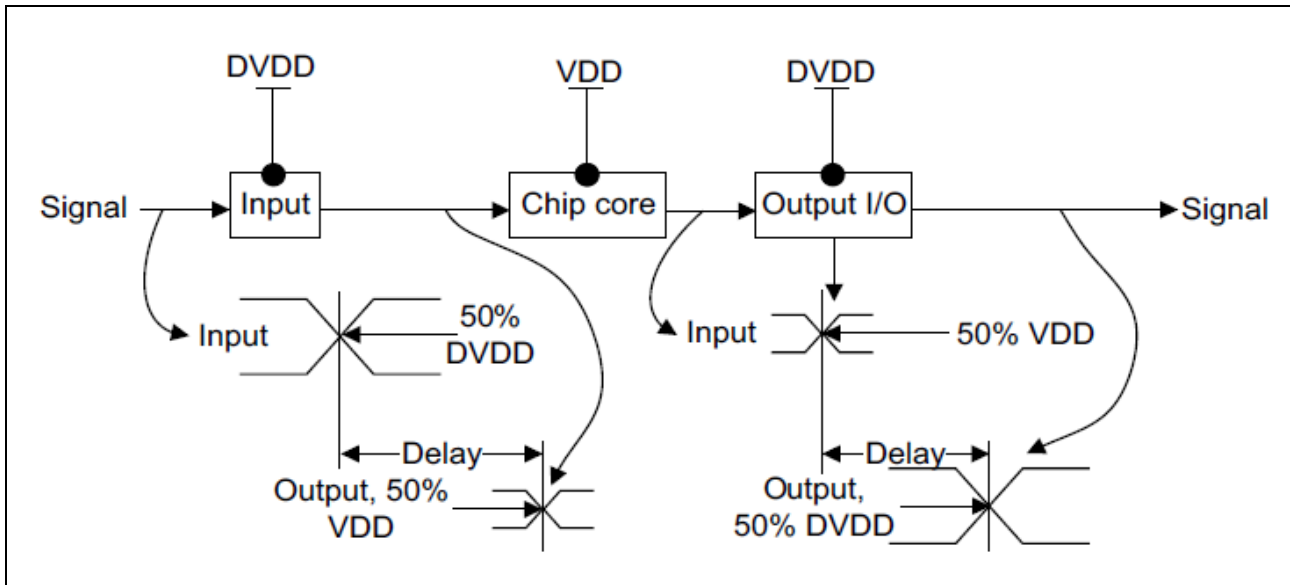

Figure 4-10 Transmission Delay

4.3.13 NRST Pin Characteristics

The NRST pin input driver uses the CMOS process, which is connected to an unbreakable pull-up resistor, R_{PU} (see **Table 4-31**). Unless otherwise specified, the parameters listed in **Table 4-31** were measured using ambient temperature and supply voltage in accordance with **Table 4-4**.

Table 4-31 NRST Pin Characteristics

Symbol	Parameter	Condition	Min	Typ	Max	Unit
$V_{IL(NRST)}^{(1)}$	NRST input low level voltage	-	V_{SS}	-	$0.3 \cdot V_{DD}$	V
$V_{IH(NRST)}^{(1)}$	NRST input high level voltage	-	$0.7 \cdot V_{DD}$	-	V_{DD}	
$V_{hys(NRST)}$	NRST Schmidt trigger voltage hysteresis	-	-	300	-	mV
R_{PU}	Weak pull-up equivalent resistance ⁽²⁾	$V_{IN} = V_{SS}$	30	50	80	k Ω
$V_{F(NRST)}^{(1)}$	NRST input filter pulse	$V_{DD} = 3.3V$	-	-	100	ns
$V_{NF(NRST)}^{(1)}$	NRST input unfiltered pulse	$V_{DD} = 3.3V$	300	-	-	ns

Notes:

(1) Guaranteed by design, not tested in production.

(2) The pull-up resistor is designed as a real resistor in series for a switchable PMOS implementation. The resistance of this PMON/NMOS switch is very small (about 10%).

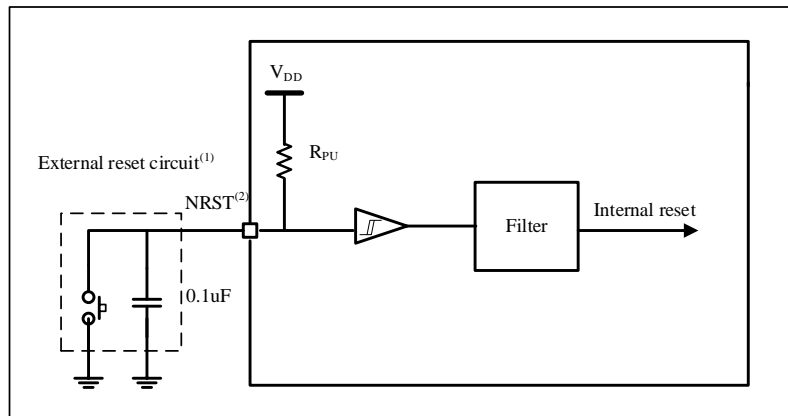
Figure 4-11 Recommended NRST Pin Protection

Notes:

(1) Acts as a filter.

(2) The user must ensure that the NRST pin potential is below the maximum $V_{IL(NRST)}$ listed in Table 4-31, otherwise the MCU cannot be reset.

4.3.14 SHRTIM Characteristics

Unless otherwise specified, the parameters in Table 4-30 are obtained by measuring the ambient temperature and supply voltage conditions that comply with the conditions in Table 4-4.

Table 4-32 SHRTIM Characteristics⁽¹⁾

Symbol	Parameter	Condition	Min	Typ	Max	Unit
T_A	Timer ambient temperature range	$f_{SHRTIM} = 250$ MHz	-40	-	105	°C
f_{SHRTIM}	HRTIM input clock for PLL calibration	As per T_A conditions	-	-	250	MHz
t_{SHRTIM}			4	-	-	ns
$t_{RES(SHRTIM)}$	High-resolution step size	$f_{SHRTIM} = 250$ MHz, T_A from -40 to 105 °C	-	125	-	ps
$Re_{SSHRTIM}$	Timer resolution	-	-	-	16	bit
t_{DTG}	Dead time generator clock period	-	0.125	-	16	t_{SHRTIM}
		$f_{SHRTIM} = 250$ MHz	0.5	-	64	ns
$ t_{DTR} / t_{DTF} _{max}$	Dead time range (absolute value)	-	-	-	511	tDTG
		$f_{SHRTIM} = 250$ MHz	-	-	34.07	µs
f_{CHPFRQ}	Chopper stage clock frequency	-	1/256	-	1/16	f_{SHRTIM}
		$f_{SHRTIM} = 250$ MHz	0.976	-	15.625	MHz
t_{1STPW}	Chopper first pulse length	-	16	-	256	t_{SHRTIM}
		$f_{SHRTIM} = 250$ MHz	0.064	-	1.024	µs

Note:

(1) Guaranteed by design, not tested in production.

Table 4-33 SHRTIM output response to fault protection⁽¹⁾

Symbol	Parameter	Condition	Min	Typ	Max ⁽²⁾	Unit
$t_{LAT(DF)}$	Digital fault response latency	Propagation delay from SHRTIM_FALTINx digital input to SHRTIM_CHxy output pin	-	9	12	ns
$T_{W(FALT)}$	Minimum Fault pulse width	-	8	-	-	
$t_{LAT(AF)}$	Analog fault response latency	Propagation delay from COMPx_INP digital input to SHRTIM_CHxy	-	22	38	

Notes:

(1) Refer to Fault paragraph in SHRTIM section.

(2) Guaranteed by design, not tested in production.

Table 4-34 SHRTIM output response to external events 1 to 10 (Low-Latency mode⁽¹⁾)

Symbol	Parameter	Condition	Min	Typ ⁽²⁾	Max ⁽²⁾	Unit
$t_{LAT(EEV)}$	Digital external event response latency	Propagation delay from SHRTIM_EXEVx digital input to SHRTIM_CHxy output pin (30 pF load)	-	11	17	ns
$T_{W(EEV)}$	Minimum external event pulse width	-	8	-	-	
$t_{LAT(AEEV)}$	Analog external event response latency	Propagation delay from COMPx_INP input pin to SHRTIM_CHxy output pin (30pF load)	-	24	42	

Notes:

(1) Refer to Latency to external events paragraph in SHRTIM section.

(2) Guaranteed by design, not tested in production.

Table 4-35 SHRTIM output response to external events 1 to 10 (Synchronous mode⁽¹⁾)

Symbol	Parameter	Condition	Min	Typ	Max ⁽²⁾	Unit
$t_{LAT(EEV)}$	Digital external event response latency	Propagation delay from SHRTIM_EXEVx digital input to SHRTIM_CHxy output pin (30 pF load) ⁽³⁾	-	47	51	ns
$t_{LAT(AEEV)}$	Analog external event response latency	Propagation delay from COMPx_INP input pin to SHRTIM_CHxy output pin ⁽³⁾	-	58	71	ns
$t_{W(EEV)}$	Minimum external event pulse width	-	8	-	-	ns
$T_{JIT(EEV)}$	External event response jitter	Jitter of the delay from SHRTIM_EXEVx digital input or COMPx_INP to SHRTIM_CHxy output pin	-	-	1	$t_{SHRTIM}^{(4)}$

Notes:

(1) Refer to Latency to external events paragraph in SHRTIM section.

(2) Guaranteed by design, not tested in production.

(3) This parameter is given for $f_{HRTIM} = 250$ MHz.

(4) $T_{SHRTIM} = 1 / f_{SHRTIM}$ with $f_{HRTIM} = 250$ MHz.

Table 4-36 SHRTIM synchronization input / output⁽¹⁾

Symbol	Parameter	Condition	Min	Typ	Max	Unit
$t_{W(SYNCIN)}$	Minimum pulse width on SYNCIN inputs, including SHRTIM_SCIN	-	1	-	-	t_{SHRTIM}
$t_{RES(ESR)}$	Response time to external synchronization request	-	-	-	3	t_{SHRTIM}
$t_{W(SYNCOUT)}$	Pulse width on SHRTIM_SCOUT output	-	-	16	-	t_{SHRTIM}
		$f_{SHRTIM} = 250$ MHz	-	64	-	ns

Note:

(1) Refer to Latency to external events paragraph in SHRTIM section.

4.3.15 Timer Characteristics

The parameters listed in Table 4-37, Table 4-38, Table 4-39, Table 4-40 are guaranteed by design, not tested in production.

See section 4.3.12 for details on the features of the I/O alternate function pins (output comparison, input capture,

external clock, PWM output)..

Table 4-37 ATIM1/2/3 Characteristics⁽¹⁾

Symbol	Parameter	Condition	Min	Max	Unit
$t_{res(TIM)}$	Timer resolution time	-	1	-	$t_{TIMxCLK}$
		$f_{TIMxCLK} = 200MHz$	5	-	ns
f_{EXT}	Timer external clock frequency on CH1 to CH4	-	0	$f_{TIMxCLK}/2$	MHz
		$f_{TIMxCLK} = 200MHz$	0	100	MHz
Re_{TIM}	Timer resolution	-	-	16	bit
$t_{COUNTER}$	16 bit counter clock cycle when internal clock is selected	-	1	65536	$t_{TIMxCLK}$
		$f_{TIMxCLK} = 200MHz$	0.005	327.68	μs
t_{MAX_COUNT}	Maximum possible count	-	-	65536x65536	$t_{TIMxCLK}$
		$f_{TIMxCLK} = 200MHz$	-	21.5	s

Note:

(1) Guaranteed by design, not tested in production.

Table 4-38 GTIM1/2/3/4/5/6/7 Characteristics⁽¹⁾

Symbol	Parameter	Condition	Min	Max	Unit
$t_{res(TIM)}$	Timer resolution time	-	1	-	$t_{TIMxCLK}$
		$f_{TIMxCLK} = 100MHz$	10	-	ns
		$f_{TIMxCLK} = 180MHz$	5.56	-	ns
f_{EXT}	Timer external clock frequency on CH1 to CH4	-	0	$f_{TIMxCLK}/2$	MHz
		$f_{TIMxCLK} = 100MHz$	0	50	MHz
		$f_{TIMxCLK} = 180MHz$	0	90	MHz
Re_{TIM}	Timer resolution	-	-	16	bit
$t_{COUNTER}$	16 bit counter clock cycle when internal clock is selected	-	1	65536	$t_{TIMxCLK}$
		$f_{TIMxCLK} = 100MHz$	0.01	655	μs
		$f_{TIMxCLK} = 180MHz$	0.00556	364	μs
t_{MAX_COUNT}	Maximum possible count	-	-	65536x65536	$t_{TIMxCLK}$
		$f_{TIMxCLK} = 100MHz$	-	42.9	s
		$f_{TIMxCLK} = 180MHz$	-	23.9	s

Note:

(1) Guaranteed by design, not tested in production.

Table 4-39 GTIM8/9/10 Characteristics⁽¹⁾

Symbol	Parameter	Condition	Min	Max	Unit
$t_{res(TIM)}$	Timer resolution time	-	1	-	$t_{TIMxCLK}$
		$f_{TIMxCLK} = 200MHz$	5	-	ns
f_{EXT}	Timer external clock frequency on CH1 to CH4	-	0	$f_{TIMxCLK}/2$	MHz
		$f_{TIMxCLK} = 200MHz$	0	100	MHz
Re_{TIM}	Timer resolution	-	-	16	bit
$t_{COUNTER}$	16 bit counter clock cycle when internal clock is selected	-	1	65536	$t_{TIMxCLK}$
		$f_{TIMxCLK} = 200MHz$	0.005	327.68	μs
t_{MAX_COUNT}	Maximum possible count	-	-	65536x65536	$t_{TIMxCLK}$
		$f_{TIMxCLK} = 200MHz$	-	21.5	s

Note:

(1) Guaranteed by design, not tested in production.

Table 4-40 LPTIMER1/2 Characteristics

Symbol	Parameter	Condition	Min	Max	Unit
t _{res(TIM)}	Maximum possible count	-	1	-	t _{TIMxCLK}
		f _{TIMxCLK} = 100MHz	10	-	ns
f _{EXT}	Maximum possible count	-	0	f _{TIMxCLK} /2	MHz
		f _{TIMxCLK} = 100MHz	0	50	MHz
RE _{TIM}	Maximum possible count	-	-	16	bit
t _{COUNTER}	Maximum possible count	-	1	65536	t _{TIMxCLK}
		f _{TIMxCLK} = 100MHz	0.01	655.36	μs
t _{MAX_COUNT}	Maximum possible count	-	-	128x65536	t _{TIMxCLK}
		f _{TIMxCLK} = 100MHz	-	83.9	ms

Note: (1) Guaranteed by design, not tested in production.

4.3.16 Watchdog Characteristics

Table 4-41 IWDG Counting Maximum And Minimum Reset Time (LSI = 32 KHz)

Prescaler	PD[2:0]	Min timeout RL[11:0] = 0	Max timeout RL[11:0] = 0xFFFF	Unit
/4	000	0.125	512	ms
/8	001	0.25	1024	
/16	010	0.5	2048	
/32	011	1.0	4096	
/64	100	2.0	8192	
/128	101	4.0	16384	
/256	11x	8.0	32768	

Note: (1) Guaranteed by design, not tested in production.

Table 4-42 WWDG Counting Maximum And Minimum Reset Time (APB1 PCLK1 = 120 Mhz)

Prescaler	TIMERB[1:0]	Min timeout	Max timeout	Unit
/1	0	0.0341	556.92	ms
/2	1	0.0682	1113.84	
/3	2	0.136	2227.68	
/4	3	0.273	4455.36	

Note: (1) Guaranteed by design, not tested in production.

4.3.17 I²C Interface Characteristics

Unless otherwise specified, the parameters listed in **Table 4-43** were measured using ambient temperature, f_{PCLK1} frequency, and V_{DD} supply voltage in accordance with **Table 4-4**.

The I²C interface of the N32H474 product conforms to the standard I²C communication protocol, but has the following limitations: SDA and SCL are not "true" open-drain pins, and when configured for open-drain output, the PMOS tube between the pin and V_{DD} is closed, but still exists.

I²C interface features are listed in **Table 4-43**. See Section 4.3.12 for details about the features of the input/output alternate function pins (SDA and SCL).

Table 4-43 I²C Interface Characteristics⁽¹⁾

Symbol	Parameter	Standard mode		Fast mode		Fast + mode		Unit
		Min	Max	Min	Max	Min	Max	
f _{SCL}	I2C interface frequency	0.0	100	0	400	0	1000	KHz
t _{h(STA)}	Start condition hold time	4.0	-	0.6	-	0.26	-	μs
t _{w(SCLL)}	SCL clock low time	4.7	-	1.3	-	0.5	-	μs
t _{w(SCLH)}	SCL clock high time	4.0	-	0.6	-	0.26	-	μs
t _{su(STA)}	Repeat start condition setup time	4.7	-	0.6	-	0.26	-	μs
t _{h(SDA)}	SDA data hold time	300	-	300	-	0	-	μs
t _{su(SDA)}	SDA setup time	250.0	-	100	-	50	-	ns
t _{r(SDA)} t _{r(SCL)}	SDA and SCL rise time	-	1000	20	300	-	120	ns
t _{f(SDA)} t _{f(SCL)}	SDA and SCL fall time	-	300	-	300	-	120	ns
t _{su(STO)}	Stop condition setup time	4.0	-	0.6	-	0.26	-	μs
t _{w(STO:STA)}	Time from stop condition to start condition (bus idle)	4.7	-	1.3	-	0.5	-	μs
C _b	Capacitive load per bus	-	400	-	400	-	550	pf
t _{v(SDA)}	Data validity time	-	3.45	-	0.9	-	0.45	μs
t _{v(ACK)}	Response time	-	3.45	-	0.9	-	0.45	μs
t _{SP}	Width of peak pulses that the input filter needs to suppress	-	-	0	50	0	50	ns

Note:(1) Guaranteed by design, not tested in production.

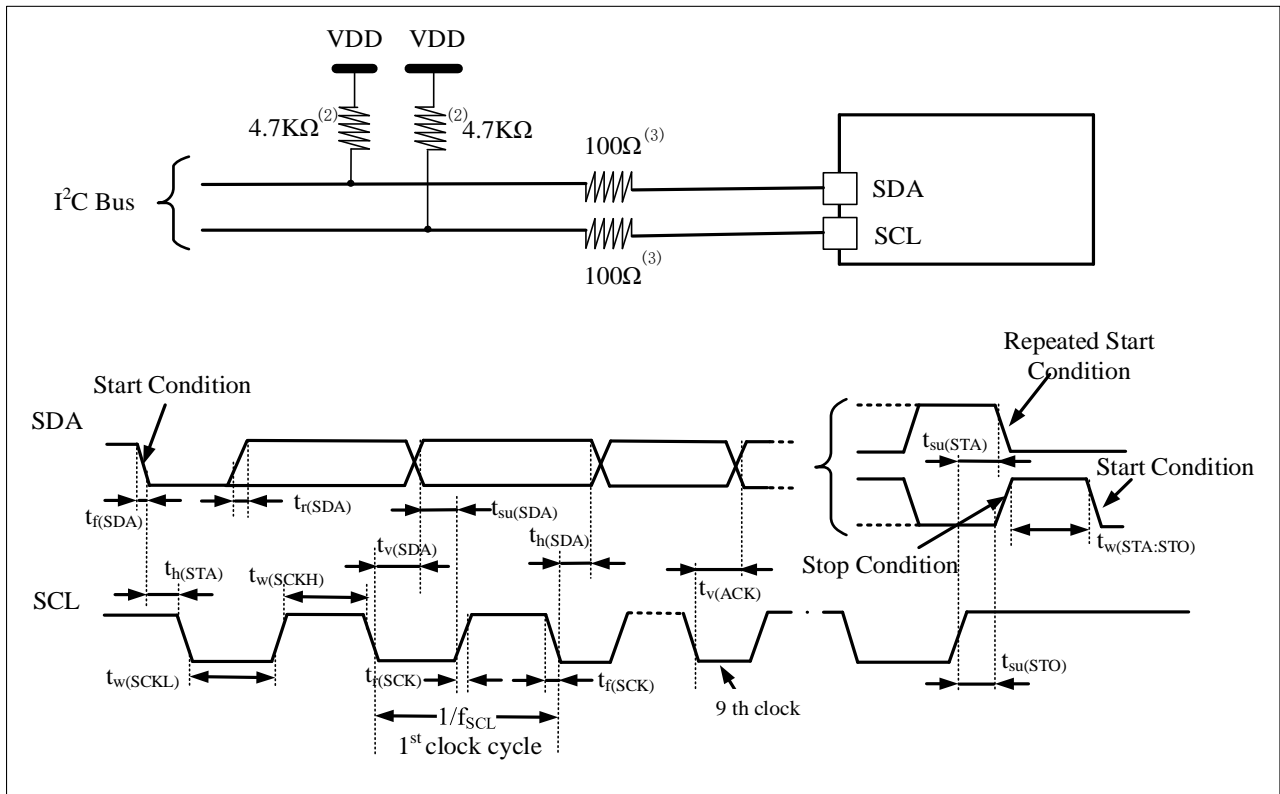
Figure 4-12 I²C Bus AC Waveform And Measuring Circuit ⁽¹⁾

Notes:

(1) The measuring point is set at the CMOS level: $0.3V_{DD}$ and $0.7V_{DD}$.

(2) The pull-up resistance depends on the I²C interface speed.

(3) The resistance value depends on the actual electrical characteristics. The signal line can be directly connected without serial resistance.

4.3.18 SPI/I²S Interface Characteristics

Unless otherwise specified, the SPI parameters listed in **Table 4-44** and the I²S parameters listed in **Table 4-45** are measured using ambient temperature, f_{CLKx} frequency, and V_{DD} supply voltage in accordance with **Table 4-4**.

See section 4.3.12 for details on the characteristics of the I/O multiplexed pins (NSS, SCLK, MOSI, MISO for SPI, WS, CLK, SD for I²S).

Table 4-44 SPI Characteristics⁽¹⁾

Symbol	Parameter	Conditions	Min	Typ	Max	Unit
f_{SCLK} $1/t_c(SCLK)$	SPI clock frequency	Master mode	-	-	60	MHz
		Slave mode	-	-	40	
DuCy(SCK)	SPI from the input clock duty cycle	SPI slave mode	45	50	55	%
$t_{su(NSS)}^{(1)}$	NSS setup time	Master mode	$t_{SCLK}/2$	-	-	ns
$t_{h(NSS)}^{(1)}$	NSS hold time	Slave mode	$t_{SCLK}/2$	-	-	
$t_w(SCLKH)^{(1)}$ $t_w(SCLKL)^{(1)}$	SCLK high and low time	Master mode	$t_{SCLK}/2 - 1$	$t_{SCLK}/2$	$t_{SCLK}/2 + 1$	
$t_{su(MI)}^{(1)}$	Data entry setup time	Master mode	3	-	-	
$t_{su(SI)}^{(1)}$		Slave mode	3.5	-	-	
$t_h(MI)^{(1)}$	Data entry hold time	Master mode	2.5	-	-	
$t_h(SI)^{(1)}$		Slave mode	2	-	-	
$t_{a(SO)}^{(1)(2)}$	Data entry hold time	Slave mode	9	-	$2 * t_{SCLK}/2$	
$t_{dis(SO)}^{(1)(3)}$	Data entry hold time	Slave mode	9	-	16	
$t_{v(SO)}^{(1)}$	Valid time of data output	Slave mode (after enable edge)	-	9	13	
$t_{v(MO)}^{(1)}$		Master mode (after enable edge)	-	3	5	
$t_h(SO)^{(1)}$	Data output hold time	Slave mode (after enable edge)	5	-	-	
$t_h(MO)^{(1)}$		Master mode (after enable edge)	0	-	-	

Notes:

(1) Guaranteed by design, not tested in production.

(2) The minimum value represents the minimum time to drive the output, and the maximum value represents the maximum time to get the data correctly.

(3) The minimum value represents the minimum time for turning off the output and the maximum value represents the maximum time for placing the data line in a high resistance state.

Figure 4-13 SPI Timing Diagram-Slave Mode And CPHA=0

Figure 4-14 SPI Timing Diagram-Slave Mode And CPHA=1⁽¹⁾

Note: (1) The measuring point is set at the CMOS level: $0.3V_{DD}$ and $0.7V_{DD}$.

Figure 4-15 SPI Timing Diagram-Master Mode⁽¹⁾

Note: (1) The measuring point is set at the CMOS level: $0.3V$ and $0.7V_{DD}$.

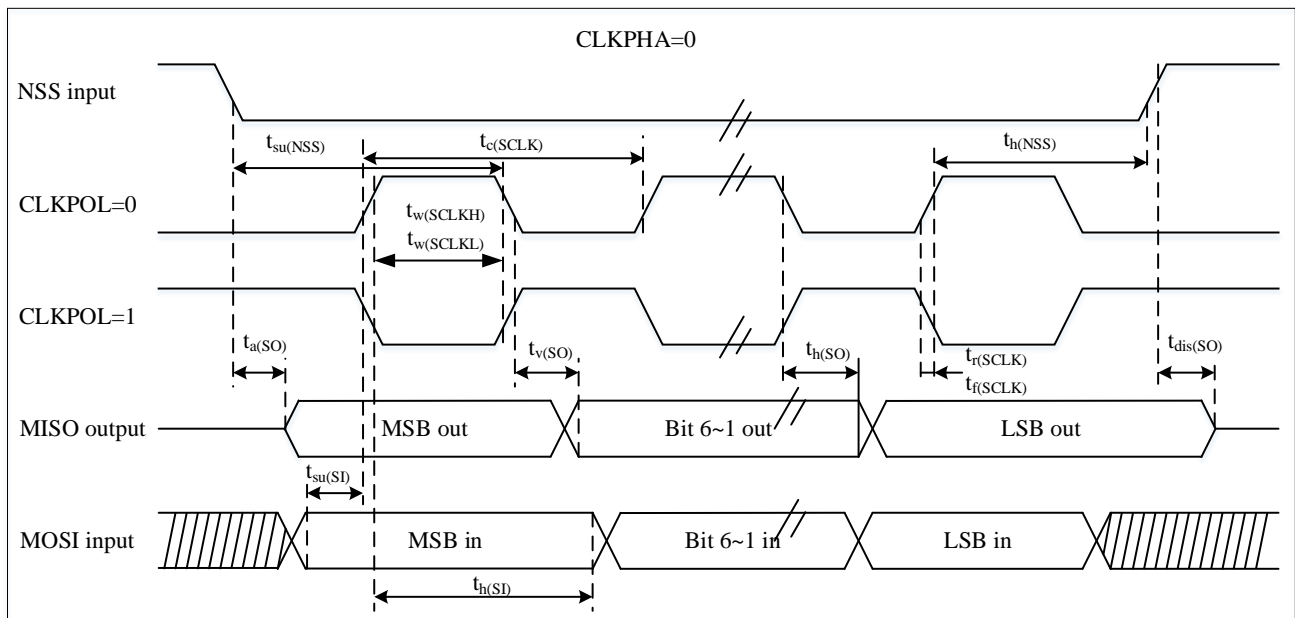
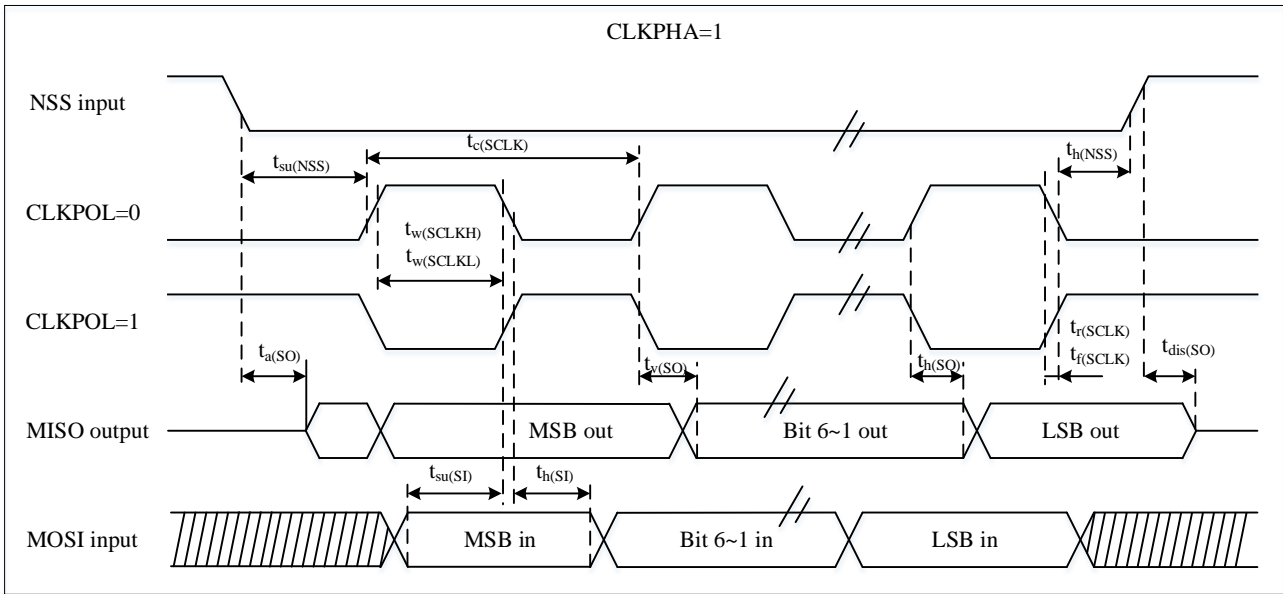
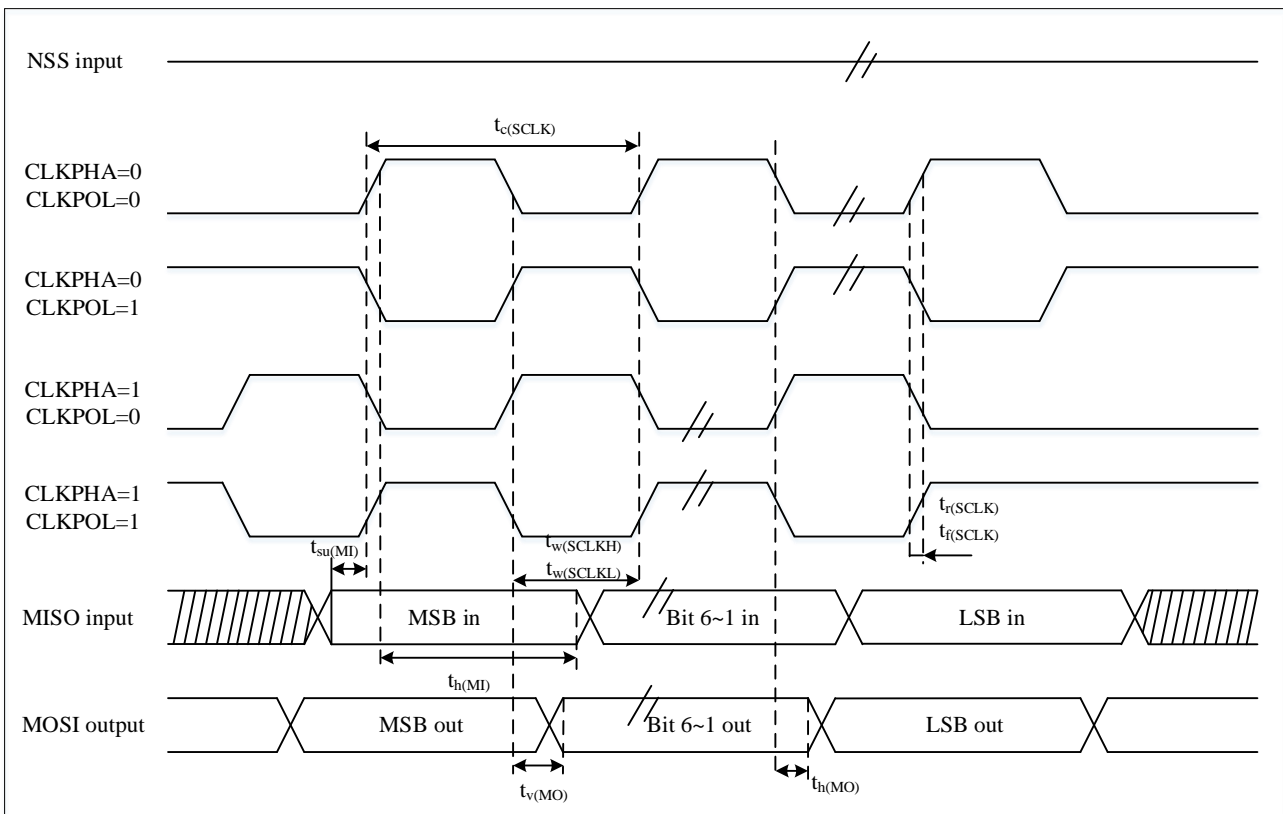
Table 4-45 I²S Characteristics ⁽¹⁾

Symbol	Parameter	Conditions		Min	Max	Unit
f_{MCLK}	I ² S main clock frequency	Master mode		256x8K	256Fs ⁽³⁾	MHz
f_{CLK} $1/t_{c(CLK)}$	I ² S clock frequency	Master mode (32 bit)		-	64Fs ⁽³⁾	
		Slave mode (32 bit)		-	64Fs ⁽³⁾	
DuCy(SCK)	I ² S input clock duty cycle	I ² S slave mode		30	70	%
$t_{v(WS)}^{(1)}$	WS valid time	Master mode	-	6	6	ns
			-	6	6	
$t_{h(WS)}^{(1)}$	WS hold time	Master mode	2	-	-	
			2	2	-	
$t_{su(WS)}^{(1)}$	WS setup time	Slave mode	7	-	-	
			7	-	-	
$t_{h(WS)}^{(1)}$	WS hold time	Slave mode	0	-	-	
			0	-	-	
$t_{w(CLKH)}^{(1)}$	CLK high and low times	Master mode, $f_{PCLK} = 16\text{MHz}$, audio 48kHz	312.5		-	
$t_{w(CLKL)}^{(1)}$			345		-	
$t_{su(SD_MR)}^{(1)}$	Data input setup time	Master receiver	6	-	-	
			6	-	-	
$t_{su(SD_SR)}^{(1)}$	Data input setup time	Slave receiver	7	-	-	
			7	-	-	
$t_{h(SD_MR)}^{(1)(2)}$	Data input hold time	Master receiver	0	-	-	
			0	0	-	
$t_{h(SD_SR)}^{(1)(2)}$	Data input hold time	Slave receiver	1	-	-	
			1	1	-	
$t_{v(SD_ST)}^{(1)(2)}$	Data output valid time	Slave transmitter (after enable edge)	-	15	15	
			-	15	15	
$t_{h(SD_ST)}^{(1)}$	Data output hold time	Slave transmitter (after enable edge)	4	-	-	
			4	-	-	
$t_{v(SD_MT)}^{(1)(2)}$	Data output valid time	Master transmitter (after enable edge)	-	6	6	
			-	6	6	
$t_{h(SD_MT)}^{(1)}$	Data output hold time	Master transmitter (after enable edge)	0	-	-	
			0	-	-	

Notes:

(1) Guaranteed by design, not tested in production.

(2) Depends on f_{PCLK} . For example, if $f_{PCLK} = 8\text{ MHz}$, then $T_{PCLK} = 1/f_{PCLK} = 125\text{ ns}$.

(3) Audio signal sampling frequency.

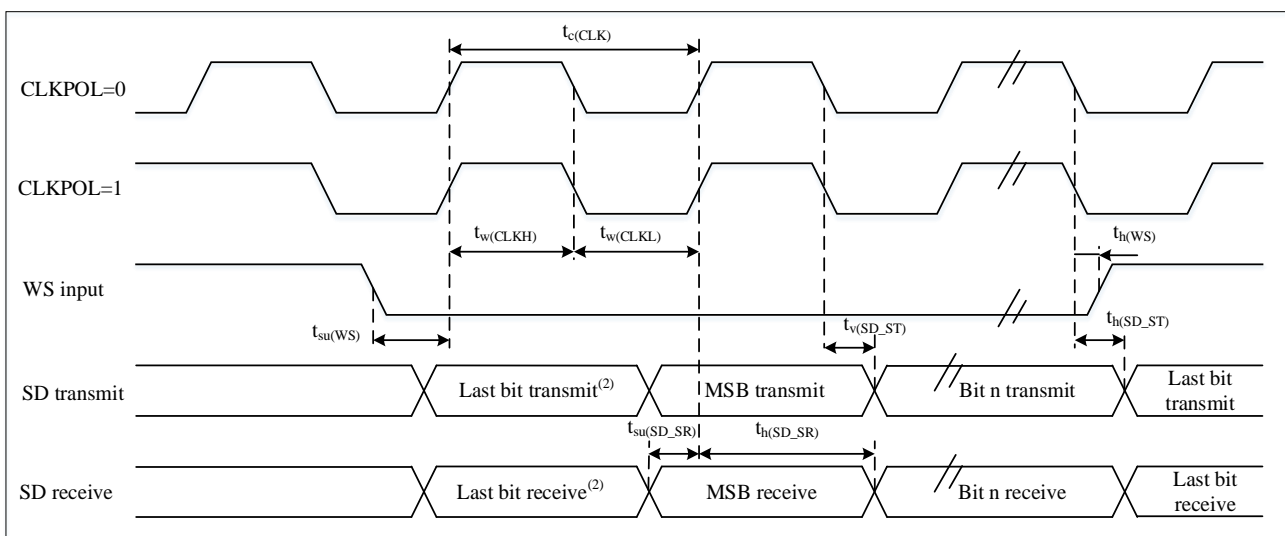
Figure 4-16 I²S Slave Mode Timing Diagram (Philips Protocol) ⁽¹⁾

Notes:

(1) The measuring point is set at the CMOS level: $0.3V_{DD}$ and $0.7V_{DD}$.

(2) Transmit/receive of the last byte. There is no least significant transmit/receive before the first byte.

Figure 4-17 I²S Master Mode Timing Diagram (Philips Protocol) ⁽¹⁾

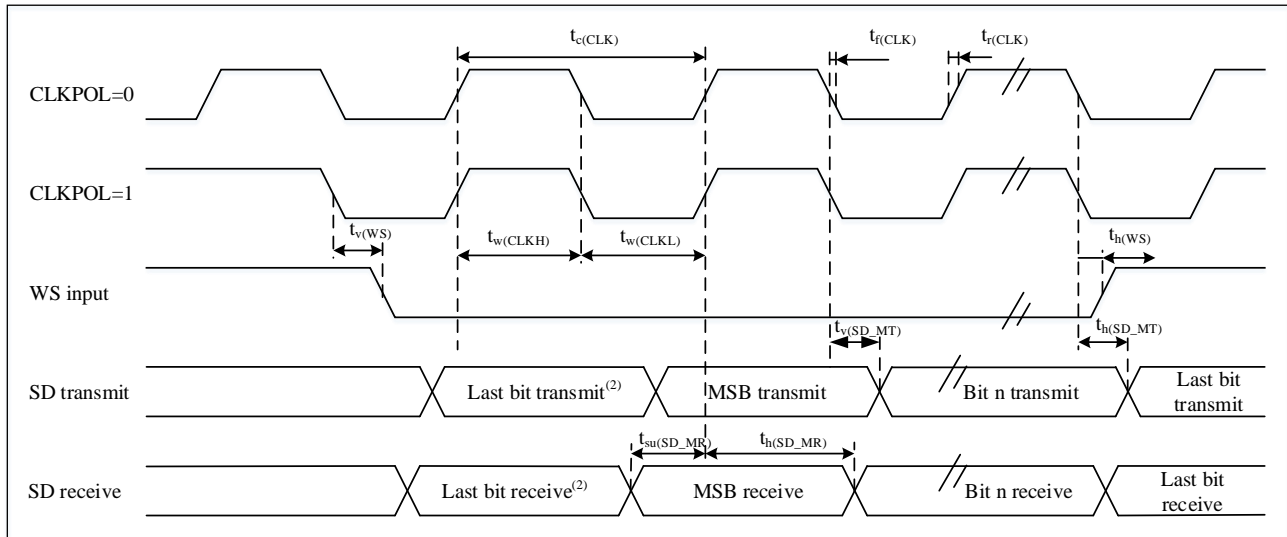

Notes:

(1) The measuring point is set at the CMOS level: $0.3V_{DD}$ and $0.7V_{DD}$.

(2) Send/receive of the last byte. There is no least significant send/receive before the first byte.

4.3.19 xSPI Characteristics

Table 4-46 Characteristics Of XSPI In Single Data Rate (SDR) Mode

Symbol	Parameter	Min	Typ	Max	Unit
f_{CK} $1/t_{CK}$	xSPI clock frequency	-	-	60	MHz
$t_{w(CKH)}$	SCK high/low time	$t_{CK}/2-0.5$	-	$t_{CK}/2$	ns
$t_{w(CKL)}$		$t_{CK}/2-0.5$	-	$t_{CK}/2$	
$t_{s(IN)}$	Data input setup time	2.5	-	-	ns
$t_{h(IN)}$	Data input hold time	5.5	-	-	ns
$t_{v(OUT)}$	Data output valid time	-	2.5	3.5	ns
$t_{h(OUT)}$	Data output hold time	2.5	-	-	ns

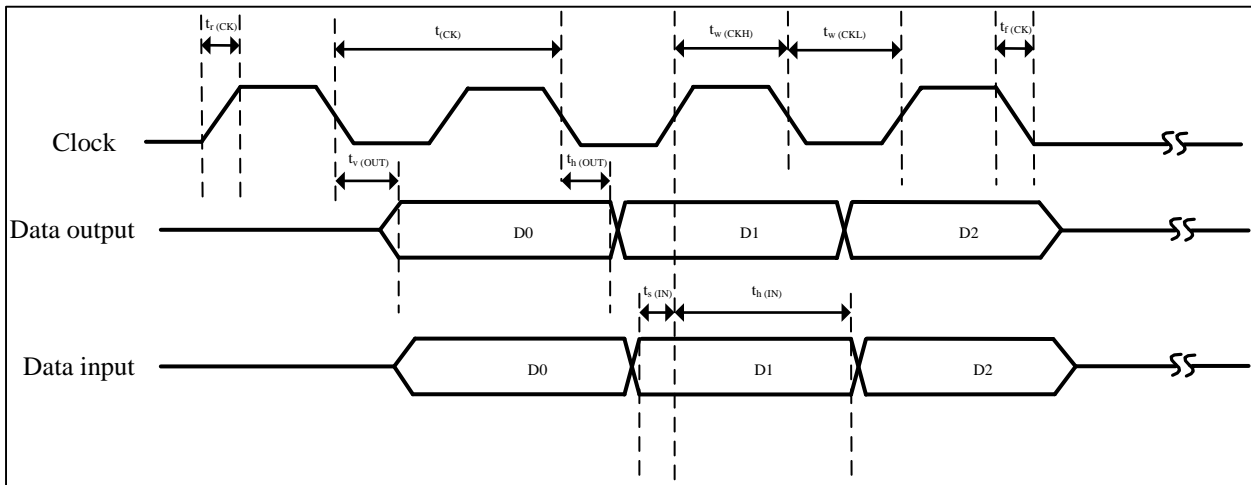
Figure 4-18 Timing of XSPI in Single Data Rate (SDR) Mode

Table 4-47 Features of XSPI in Double Data Rate (DDR) Mode

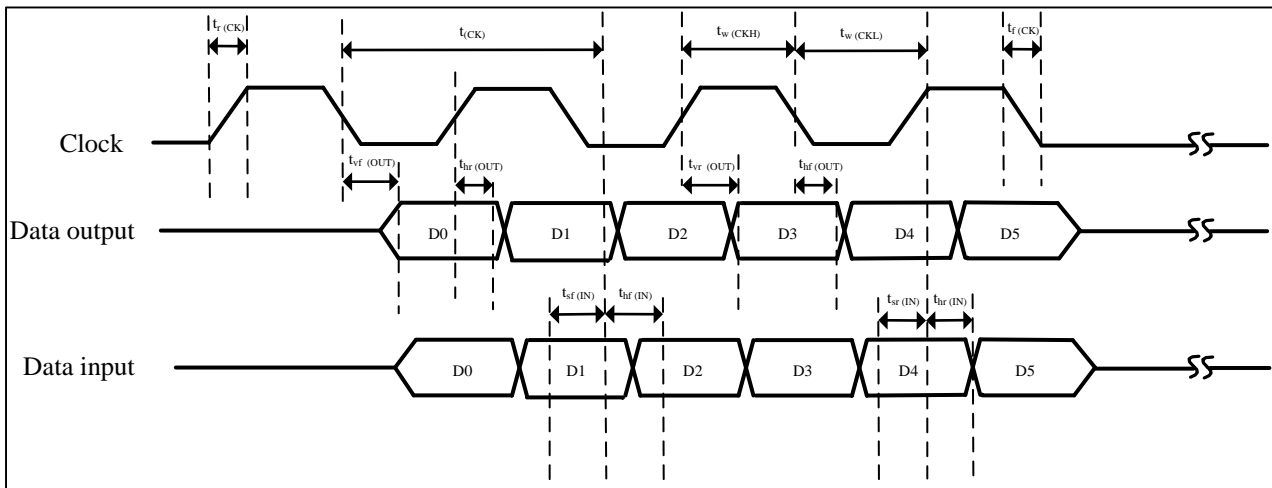
Symbol	Parameter	Min	Typ	Max	Unit
f_{CK} $1/t_{(CK)}$	xSPI clock frequency	-	-	60	MHz
$t_{w(CKH)}$	SCK high/low time	$t_{(CK)}/2-0.5$	-	$t_{(CK)}/2$	ns
$t_{w(CKL)}$		$t_{(CK)}/2-0.5$	-	$t_{(CK)}/2$	ns
$t_{sf(IN)}$	Data input setup time	3	-	-	ns
$t_{sr(IN)}$		5	-	-	ns
$t_{hf(IN)}$; $t_{hr(IN)}$	Data input hold time	2	-	-	ns
$t_{vf(OUT)}$; $t_{vr(OUT)}$	Data output valid time	-	-	5	ns
$t_{hf(OUT)}$; $t_{hr(OUT)}$	Data output hold time	4	-	-	ns

Figure 4-19 Timing of XSPI in Double Data Rate (DDR) Mode

Table 4-48 Features of XSPI in Double Data Rate (DDR) Mode

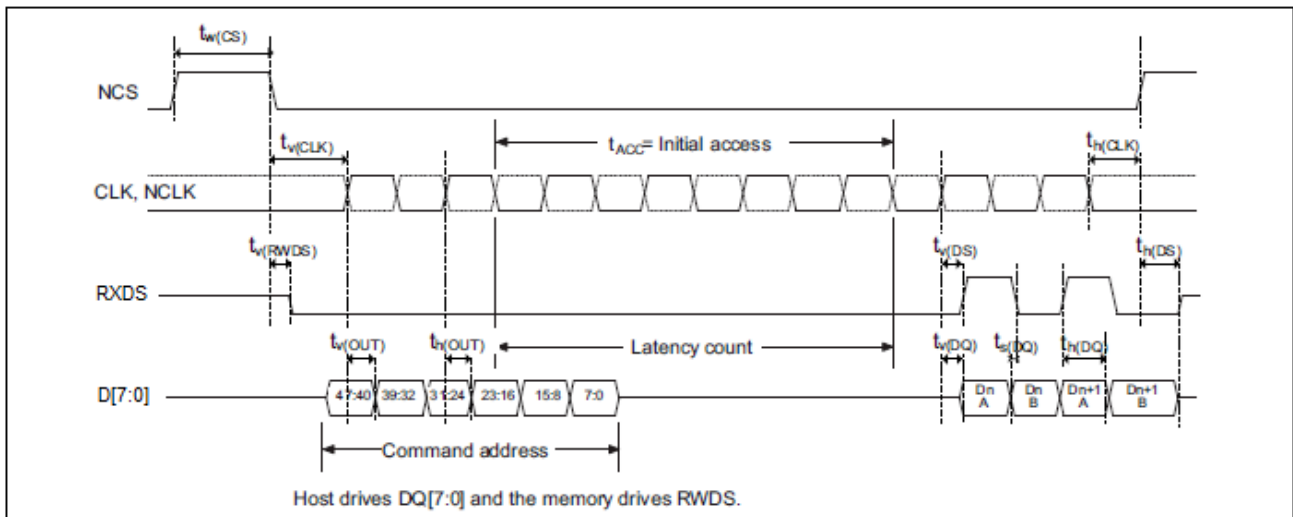
Symbol	Parameter	Min	Typ	Max	Unit
f_{CK} $1/t_{(CK)}$	xSPI clock frequency	-	-	60	MHz
$t_{w(CKH)}$	SCK high/low time	$t_{(CK)}/2-0.5$	-	$t_{(CK)}/2$	ns
$t_{w(CKL)}$		$t_{(CK)}/2-0.5$	-	$t_{(CK)}/2$	

$t_{v(CLK)}$	clock valid time	-	-	$t(CK)+2$	
$t_{h(CLK)}$	clock high time	$t(CK)+0.5$	-	-	
$t_{w(CS)}$	chip select high time	$3*t(CK)$	-	-	
$t_{v(DQ)}$	Data input valid time	0	-	-	
$t_{v(DS)}$	Data selection input valid time	0	-	-	
$t_{h(DS)}$	Data selection input hold time	0	-	-	
$t_{v(RWDS)}$	Data selection output valid time	-	-	$3*t(CK)$	
$t_{sf(DQ)}; t_{sr(DQ)}$	Input data setup time	3	-	-	ns
$t_{hf(DQ)}; t_{hr(DQ)}$	Input data hold time	2	-	-	ns
$t_{vf(OUT)}; t_{vr(OUT)}$	Output data setup time	-	6	7	ns
$t_{hf(OUT)}; t_{hr(OUT)}$	Output data hold time	3.5	-	-	ns

Figure 4-20 Timing of XSPI in Double Data Rate (RXDS) Mode

4.3.20 FEMC Characteristics

Synchronous waveforms and timings

Figure 4-21 through Figure 4-24 represent synchronous waveforms and Table 4-49 through Table 4-52 provide the corresponding timings. The results shown in these tables are obtained with the following FEMC configuration:

- AddressSetupTime = 0
- AddressHoldTime = 1
- DataSetupTime = 1

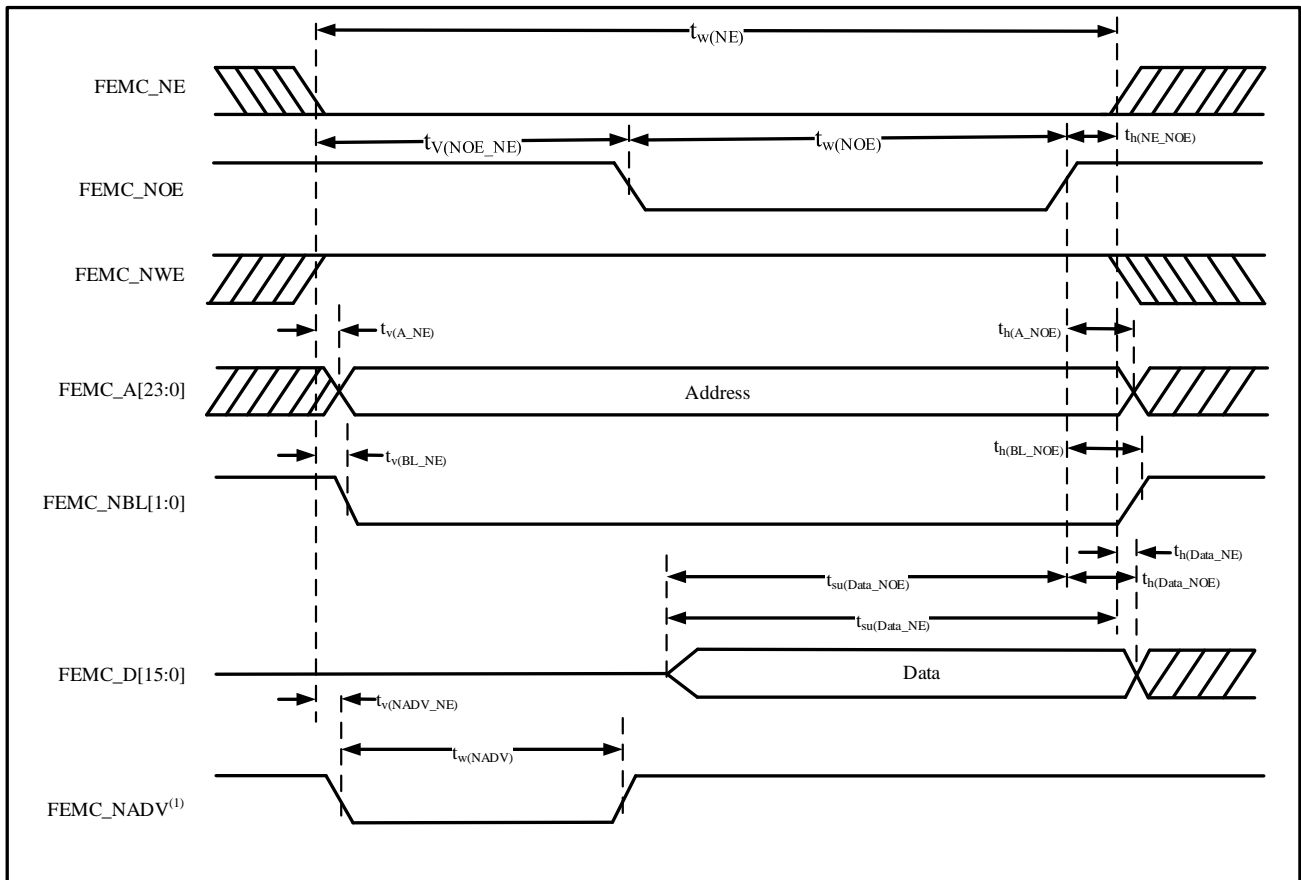
Figure 4-21 Asynchronous Non-Multiplexed SRAM/PSRAM/NOR Read Waveforms

Note:

(1) Only suitable for modes 2/B, C, and D. In mode 1, FEMC_NADV is not used.

Table 4-49 Asynchronous Non-Multiplexed SRAM/PSRAM/NOR Read Timings(1)(2)

Symbol	Parameter	Min ⁽³⁾	Max ⁽³⁾	Unit
$t_w(NE)$	FEMC_NE low time	$5t_{HCLK} - 0.5$	$5t_{HCLK} + 1$	ns
$t_v(NOE_NE)$	FEMC_NEx low to FEMC_NOE low	0.5	2	ns
$t_w(NOE)$	FEMC_NOE low time	$5t_{HCLK} - 0.5$	$5t_{HCLK} + 1$	ns
$t_h(NE_NOE)$	FEMC_NOE high to FEMC_NE high hold time	0	-	ns
$t_v(A_NE)$	FEMC_NEx low to FEMC_A valid	-	3	ns
$t_h(A_NOE)$	Address hold time after FEMC_NOE high	4	-	ns
$t_v(BL_NE)$	FEMC_NEx low to FEMC_BL valid	-	1.5	ns
$t_h(BL_NOE)$	FEMC_BL hold time after FEMC_NOE high	0	-	ns
$t_{su}(Data_NE)$	Data to FEMC_NEx high setup time	$2t_{HCLK} + 3$	-	ns
$t_{su}(Data_NOE)$	Data to FEMC_NOEx high setup time	$2t_{HCLK} + 3$	-	ns
$t_h(Data_NOE)$	Data to FEMC_NOEx high hold time	0	-	ns
$t_h(Data_NE)$	Data to FEMC_NOEx high hold time	0	-	ns
$t_v(NADV_NE)$	FEMC_NEx low to FEMC_NADV low	-	2	ns
$t_w(NADV)$	FEMC_NADV low time	-	$2t_{HCLK}$	ns

Notes:

- (1) IO drive capacity is 8 mA, Capacitive load = 30 pF
- (2) Measurement point set at CMOS level: 0.5VDD
- (3) $t_{HCLK} \geq 1/240\text{MHz}$

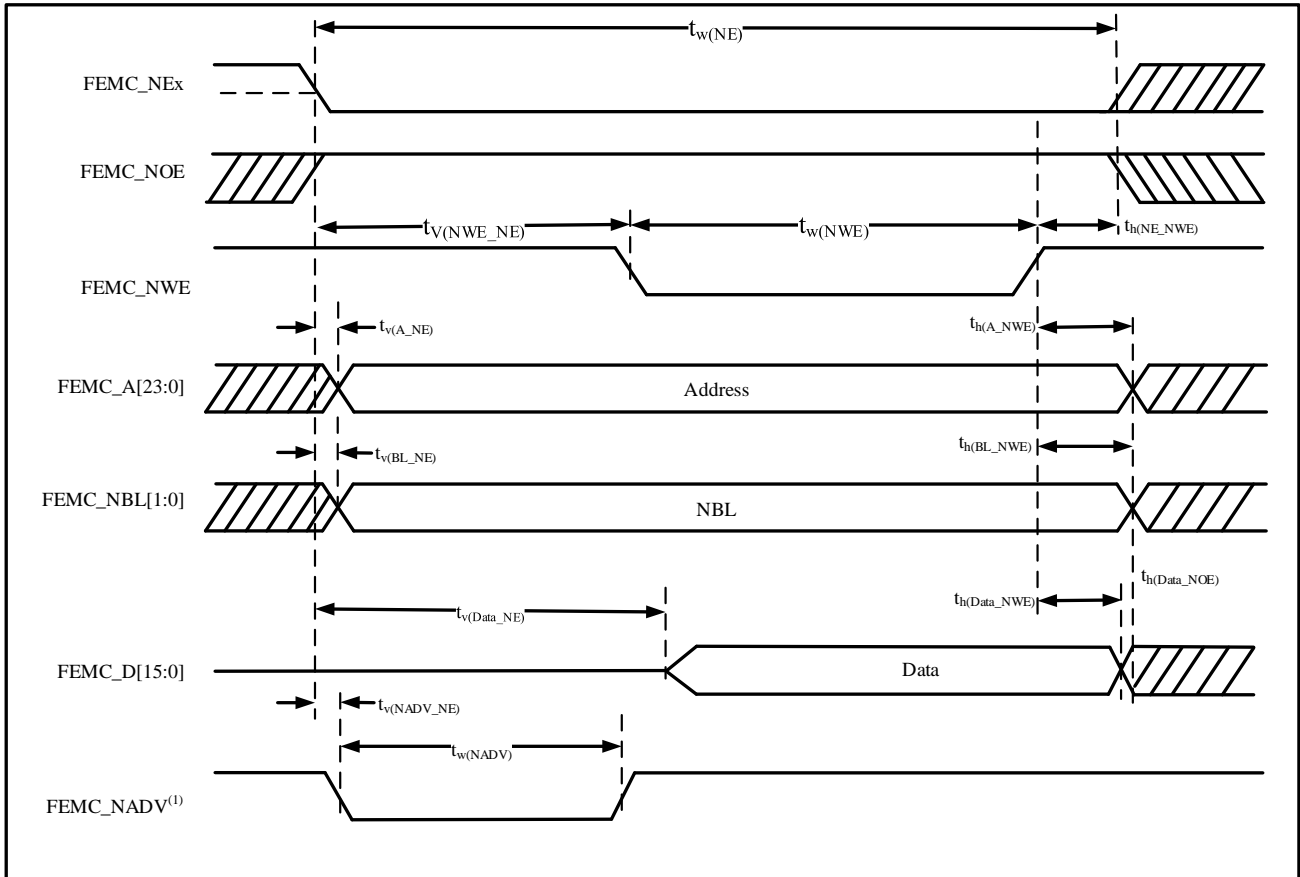
Figure 4-22 Asynchronous Non-Multiplexed SRAM/PSRAM/NOR Write Waveforms

Note:

- (1) Only suitable for modes 2/B, C, and D. In mode 1, FEMC_NADV is not used.

Table 4-50 Asynchronous Non-Multiplexed SRAM/PSRAM/NOR Write Timings(1)(2)

Symbol	Parameter	Min ⁽³⁾	Max ⁽³⁾	Unit
$t_{w(NE)}$	FEMC_NE low time	$3t_{HCLK} - 0.5$	$3t_{HCLK} + 1$	ns
$t_{v(NWE_NE)}$	FEMC_NEx low to FEMC_NWE low	$1t_{HCLK} - 0.5$	$1t_{HCLK} + 0.5$	ns
$t_{w(NWE)}$	FEMC_NWE low time	$1t_{HCLK} - 0.5$	$1t_{HCLK} + 1$	ns
$t_{h(NE_NWE)}$	FEMC_NWE high to FEMC_NE high hold time	$1t_{HCLK}$	-	ns
$t_{v(A_NE)}$	FEMC_NEx low to FEMC_A valid	-	3	ns
$t_{h(A_NWE)}$	Address hold time after FEMC_NWE high	$1t_{HCLK}$	-	ns
$t_{v(BL_NE)}$	FEMC_NEx low to FEMC_NBL valid	-	1.5	ns
$t_{h(BL_NWE)}$	FEMC_NBL hold time after FEMC_NWE high	$1t_{HCLK} - 0.5$	-	ns
$t_{v(Data_NE)}$	FEMC_NEx low to data valid	-	$1t_{HCLK} + 3$	ns
$t_{h(Data_NWE)}$	Date hold time after FEMC_NWE high	$1t_{HCLK} - 1$	-	ns
$t_{v(NADV_NE)}$	FEMC_NEx low to FEMC_NADV valid	-	2	ns

$t_{w(NADV)}$	FEMC_NADV low time	-	$1t_{HCLK} + 1$	ns
---------------	--------------------	---	-----------------	----

Notes:

(1) IO drive capacity is 8 mA, Capacitive load = 30 pF

(2) Measurement point set at CMOS level: 0.5VDD

(3) $t_{HCLK} >= 1/240\text{MHz}$

Figure 4-23 Asynchronous Multiplexed PSRAM /NOR Read Waveforms

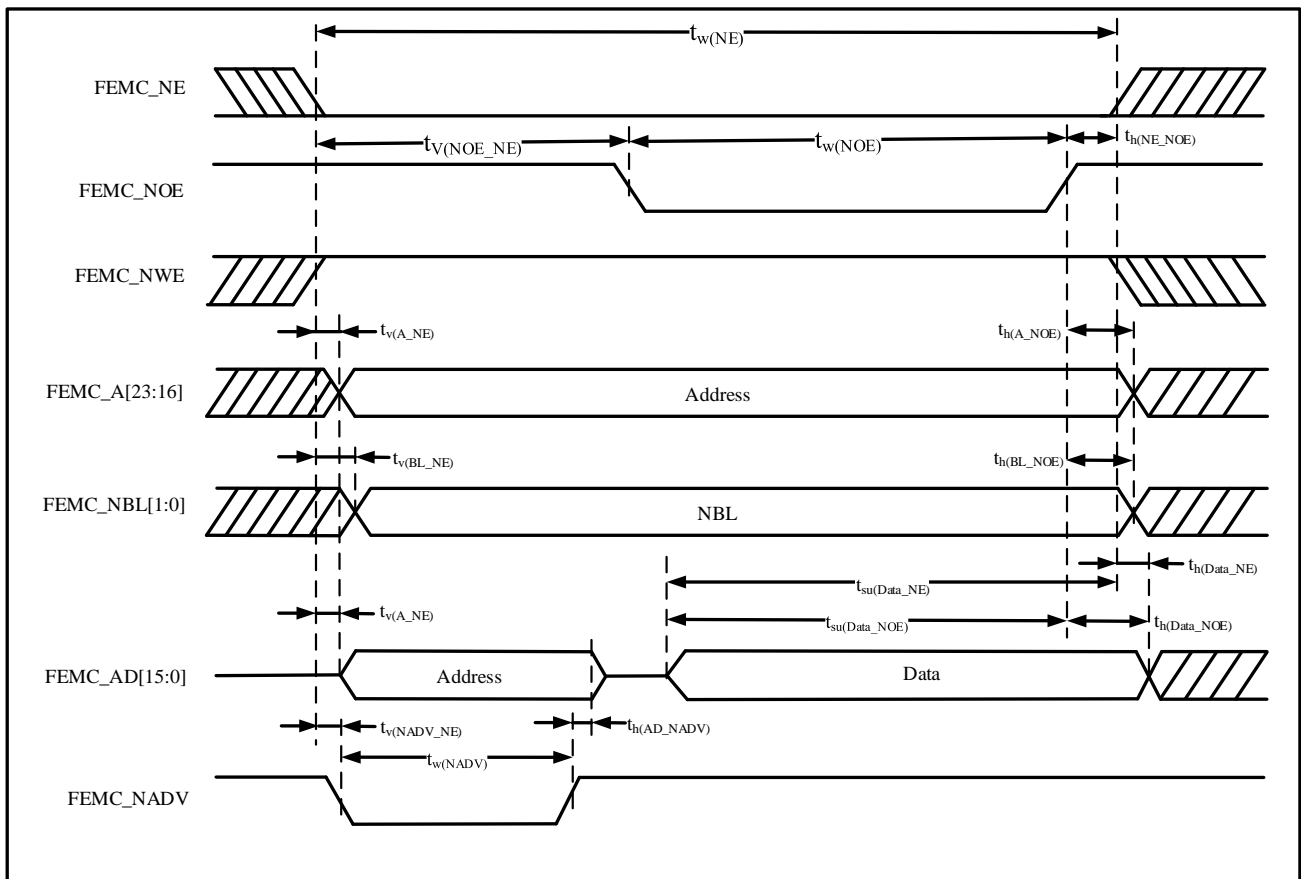

Table 4-51 Asynchronous Multiplexed PSRAM/NOR Write Timings(1)(2)

Symbol	Parameter	Min ⁽³⁾	Max ⁽³⁾	Unit
$t_{w(NE)}$	FEMC_NE low time	$7t_{HCLK} - 1$	$7t_{HCLK} + 1$	ns
$t_{v(NOE_NE)}$	FEMC_NEx low to FEMC_NOE low	$3t_{HCLK} - 0.5$	$3t_{HCLK} + 1$	ns
$t_{w(NOE)}$	FEMC_NOE low time	$4t_{HCLK} - 0.5$	$4t_{HCLK} + 1$	ns
$t_{h(NE_NOE)}$	FEMC_NOE high to FEMC_NE high hold time	0	-	ns
$t_{v(A_NE)}$	FEMC_NEx low to FEMC_A valid	-	3	ns
$t_{v(NADV_NE)}$	FEMC_NEx low to FEMC_NADV low	1	2	ns
$t_{w(NADV)}$	FEMC_NADV low time	$t_{HCLK} - 1.5$	$t_{HCLK} + 1.5$	ns
$t_{h(AD_NADV)}$	FEMC_A valid hold time after FEMC_NADV high	t_{HCLK}	-	ns
$t_{h(A_NOE)}$	FEMC_A hold time after FEMC_NOE high	$t_{HCLK} - 1$	-	ns
$t_{h(BL_NOE)}$	FEMC_BL hold time after FEMC_NOE high	0	-	ns
$t_{v(BL_NE)}$	FEMC_NEx low to FEMC_BL valid	-	1.5	ns
$t_{su(Data_NE)}$	Data to FEMC_NEx high setup time	$1t_{HCLK} + 3$	-	ns

$t_{su(Data_NOE)}$	Data to FEMC_NOE high hold time	$1t_{HCLK} + 3$	-	ns
$t_{h(Data_NE)}$	Data hold time after FEMC_NEx high	0	-	ns
$t_{h(Data_NOE)}$	Data hold time after FEMC_NOE high	0	-	ns

Notes:

(1) IO drive capacity is 8 mA, Capacitive load = 30 pF

(2) Measurement point set at CMOS level: 0.5VDD

(3) $t_{HCLK} \geq 1/240MHz$

Figure 4-24 Asynchronous Multiplexed PSRAM/NOR Write Waveforms

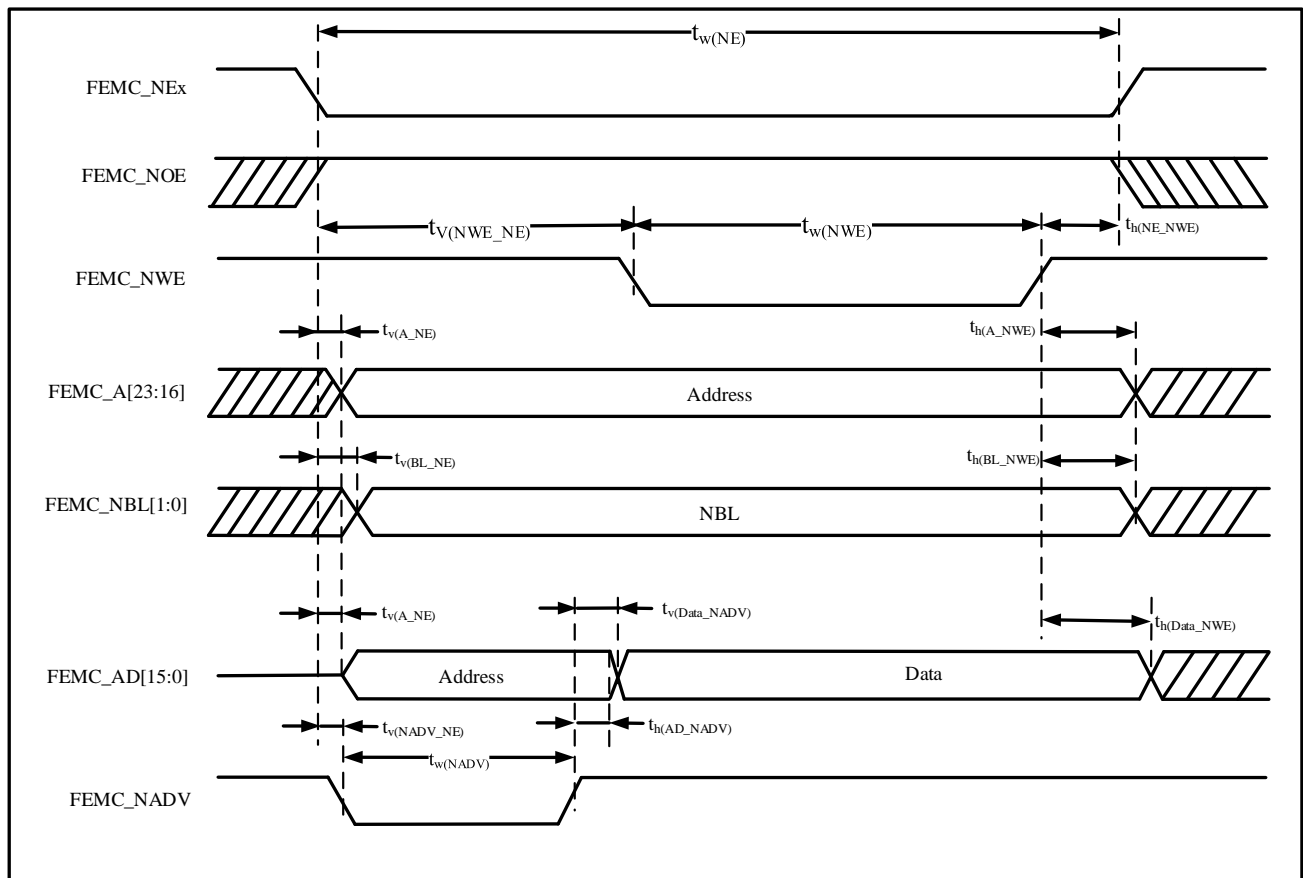

Table 4-52 Asynchronous Multiplexed PSRAM/NOR Write Timings(1)(2)

Symbol	Parameter	Min ⁽³⁾	Max ⁽³⁾	Unit
$t_{w(NE)}$	FEMC_NE low time	$5t_{HCLK} - 1$	$5t_{HCLK} + 1$	ns
$t_{v(NWE_NE)}$	FEMC_NEx low to FEMC_NWE low	$2t_{HCLK}$	$2t_{HCLK} + 1$	ns
$t_{w(NWE)}$	FEMC_NWE low time	$2t_{HCLK} - 0.5$	$2t_{HCLK} + 1$	ns
$t_{h(NE_NWE)}$	FEMC_NWE high to FEMC_NE high hold time	$t_{HCLK} - 1$	-	ns
$t_{v(A_NE)}$	FEMC_NEx low to FEMC_A valid	-	3	ns
$t_{v(NADV_NE)}$	FEMC_NEx low to FEMC_NADV low	1	2	ns
$t_{w(NADV)}$	FEMC_NADV low time	$t_{HCLK} - 1$	$t_{HCLK} + 1$	ns
$t_{h(AD_NADV)}$	FEMC_A valid hold time after FEMC_NADV high	$t_{HCLK} - 1$	-	ns
$t_{h(A_NWE)}$	FEMC_A hold time after FEMC_NWE high	$4t_{HCLK}$	-	ns
$t_{v(BL_NE)}$	FEMC_BL hold time after FEMC_NWE high	-	1.5	ns

$t_{h(BL_NWE)}$	FEMC_NWE low to FEMC_BL valid	$t_{HCLK} - 1$	-	ns
$t_{v(Data_NADV)}$	Data hold time after FEMC_NADV high	-	$t_{HCLK} + 1$	ns
$t_{h(Data_NWE)}$	Data hold time after FEMC_NWE high	t_{HCLK}	-	ns

Notes:

(1) IO drive capacity is 8 mA, Capacitive load = 30 pF

(2) Measurement point set at CMOS level: 0.5VDD

(3) $t_{HCLK} \geq 1/240MHz$

Synchronous waveforms and timings

Figure 4-25 through Figure 4-28 represent synchronous waveforms and Table 4-53 through Table 4-56 provide the corresponding timings. The results shown in these tables are obtained with the following FEMC configuration:

- BurstAccMode = FEMC_NOR_SRAM_BURST_MODE_ENABLE, enable burst mode
- MemoryType = FEMC_MEM_TYPE_PSRAM, memory type is PSRAM
- WriteBurst = FEMC_NOR_SRAM_BURST_WRITE_ENABLE, enable burst write operation
- CLKDiv = 1, (1 memory cycle = 2 HCLK cycles) (Note: ClkDiv is the CLKDIV bit in the FEMC_SNTCFGx register)
- DataLatency = 1 for NOR Flash; DataLatency = 0 for PSRAM

(Note: DataLatency is the DATAHLD bit in the FEMC_SNTCFGx register)

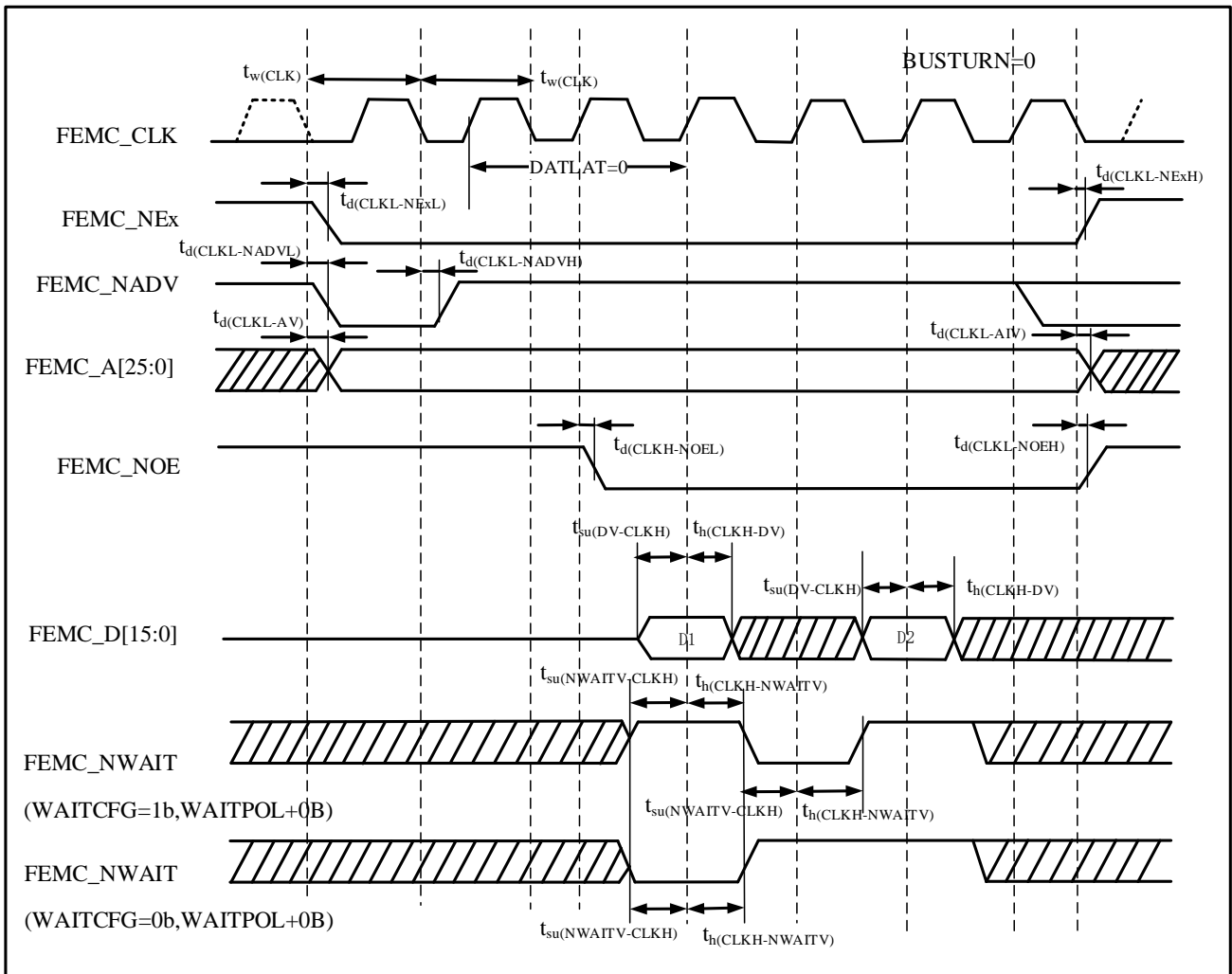
Figure 4-25 Synchronous Non-Multiplexed PSRAM/NOR Read Waveforms

Table 4-53 Synchronous Non-Multiplexed PSRAM/NOR Read Timings⁽¹⁾⁽²⁾

Symbol	Parameter	Min	Max	Unit
$t_w(\text{CLK})$	FEMC_CLK period	16.67	-	ns
$t_d(\text{CLKL-NExL})$	FEMC_CLK low to FEMC_NEx low	-	1	ns
$t_d(\text{CLKL-NExH})$	FEMC_CLK low to FEMC_NEx high	0	-	ns
$t_d(\text{CLKL-NADV})$	FEMC_CLK low to FEMC_NADV low	-	2	ns
$t_d(\text{CLKL-NADVH})$	FEMC_CLK low to FEMC_NADV high	3	-	ns
$t_d(\text{CLKL-AV})$	FEMC_CLK low to FEMC_Ax valid	-	2	ns
$t_d(\text{CLKL-AIV})$	FEMC_CLK low to FEMC_Ax invalid	2	-	ns
$t_d(\text{CLKL-NOEL})$	FEMC_CLK low to FEMC_NOE low	-	1	ns
$t_d(\text{CLKL-NOEH})$	FEMC_CLK low to FEMC_NOE high	1.5	-	ns
$t_{su}(\text{DV-CLKH})$	FEMC_D[15:0] valid before FEMC_CLK high	3	-	ns
$t_h(\text{CLKH-DV})$	FEMC_D[15:0] valid after FEMC_CLK high	2	-	ns
$t_{su}(\text{NWAITV-CLKH})$	FEMC_NWAIT valid before FEMC_CLK high	3	-	ns
$t_h(\text{CLKH-NWAITV})$	FEMC_NWAIT valid after FEMC_CLK high	2	-	ns

Notes:

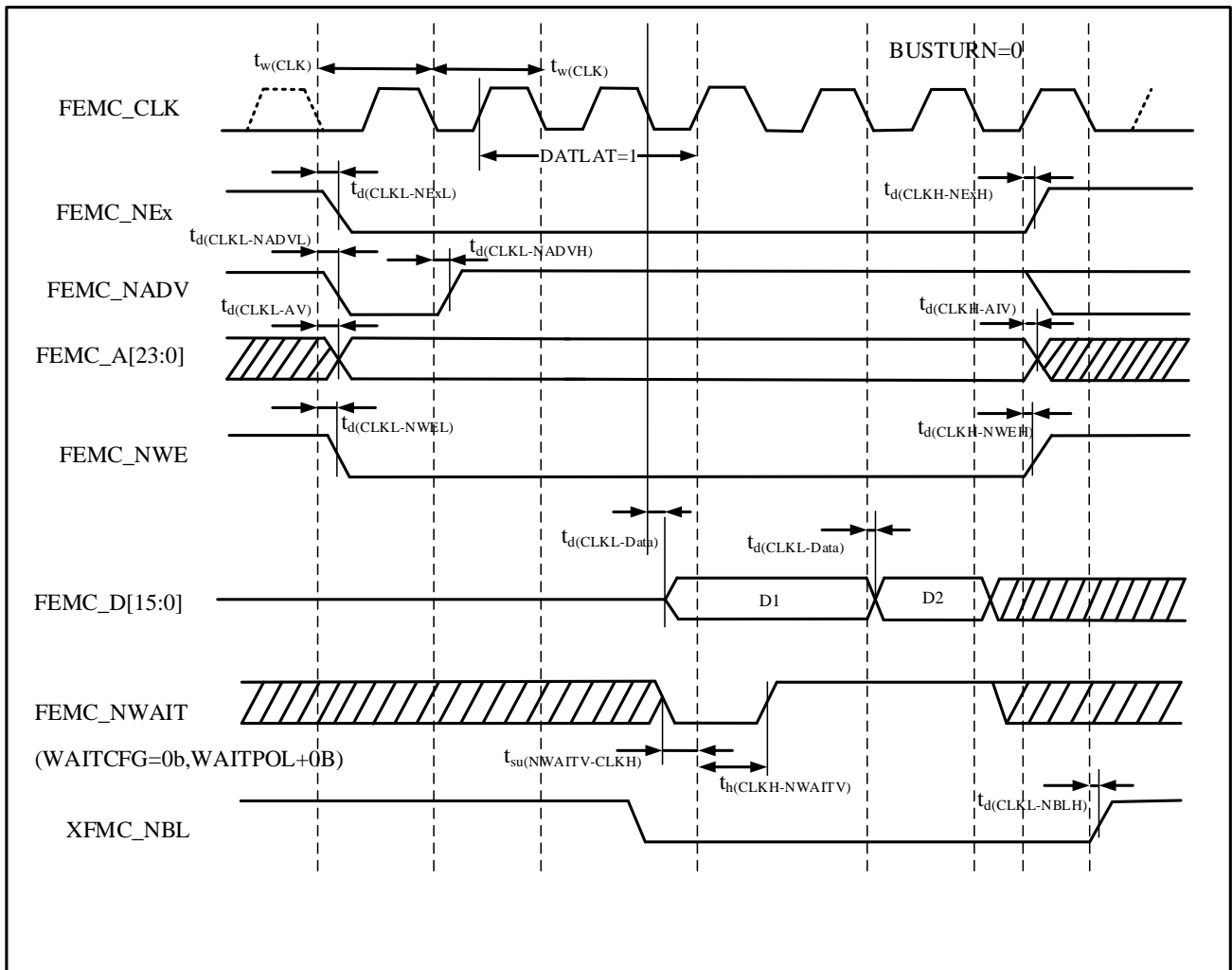
- (1) IO drive capacity is 8 mA, Capacitive load = 30 pF
 (2) Measurement point set at CMOS level: 0.5VDD

Figure 4-26 Synchronous Non-Multiplexed PSRAM Write Waveforms

Table 4-54 Synchronous Non-Multiplexed PSRAM Write Timings⁽¹⁾⁽²⁾

Symbol	Parameter	Min	Max	Unit
$t_w(\text{CLK})$	FEMC_CLK period	16.67	-	ns
$t_d(\text{CLKL-NExL})$	FEMC_CLK low to FEMC_NEx low	-	1	ns
$t_d(\text{CLKH-NExH})$	FEMC_CLK low to FEMC_NEx high	1	-	ns
$t_d(\text{CLKL-NADVL})$	FEMC_CLK low to FEMC_NADV low	-	2	ns
$t_d(\text{CLKL-NADVH})$	FEMC_CLK low to FEMC_NADV high	3	-	ns
$t_d(\text{CLKL-AV})$	FEMC_CLK low to FEMC_Ax valid	-	3	ns
$t_d(\text{CLKH-AIV})$	FEMC_CLK low to FEMC_Ax invalid	2	-	ns
$t_d(\text{CLKL-NWEL})$	FEMC_CLK low to FEMC_NWE low	-	1	ns
$t_d(\text{CLKH-NWEH})$	FEMC_CLK low to FEMC_NWE high	1.5	-	ns
$t_d(\text{CLKL-Data})$	FEMC_D[15:0] valid after FEMC_CLK high	-	3	ns
$t_{su}(\text{NWAITV-CLKH})$	FEMC_NWAIT valid before FEMC_CLK high	2	-	ns
$t_h(\text{CLKH-NWAITV})$	FEMC_NWAIT valid after FEMC_CLK high	3	-	ns

$t_{d(CLKL-NBLH)}$	FEMC_CLK low to FEMC_NBL high	2	-	ns
--------------------	-------------------------------	---	---	----

Notes:

(1) IO drive capacity is 8 mA, Capacitive load = 30 pF

(2) Measurement point set at CMOS level: 0.5VDD

Figure 4-27 Synchronous Multiplexed NOR/PSRAM Write Waveforms

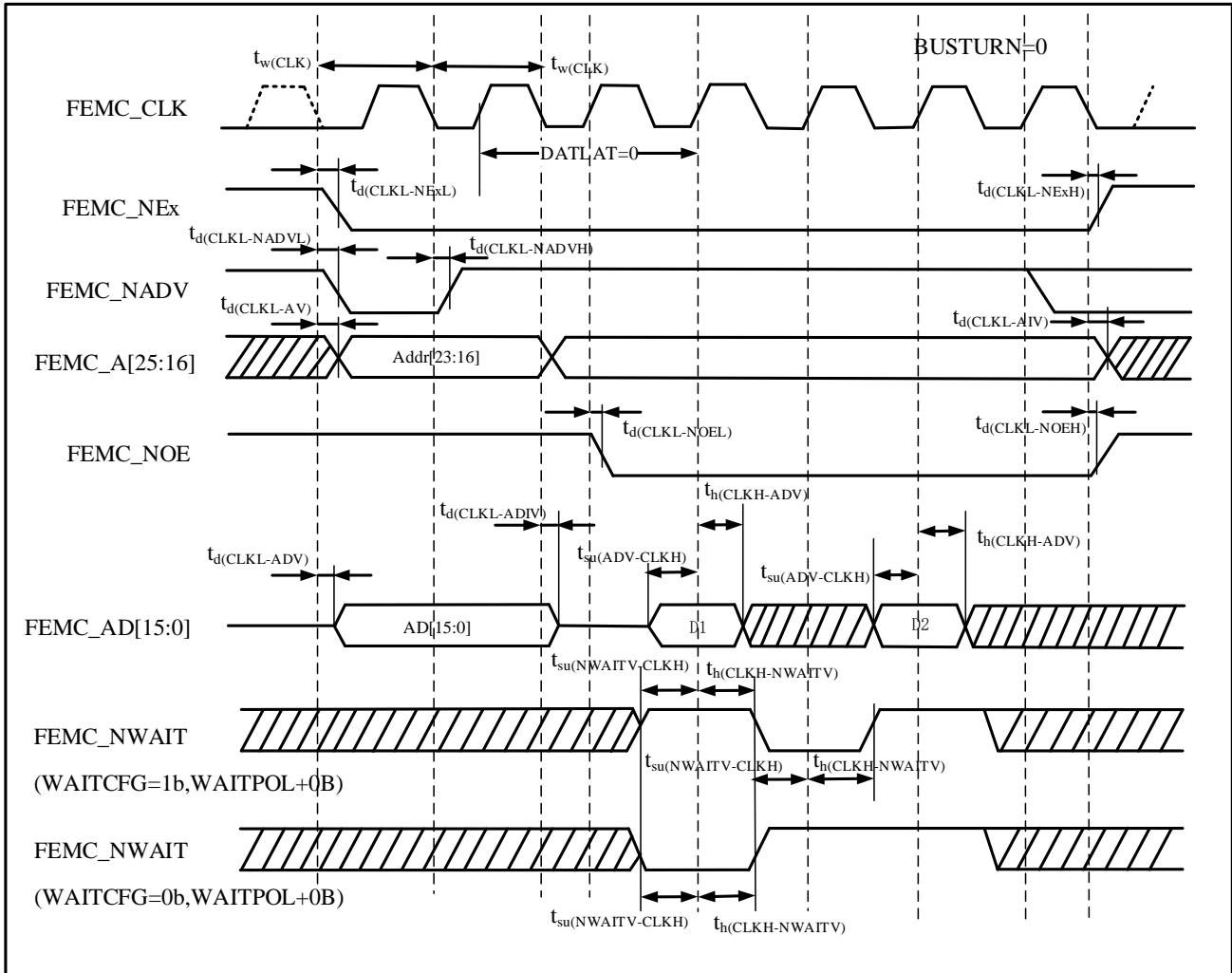

Table 4-55 Synchronous Multiplexed NOR/PSRAM Write Timings⁽¹⁾⁽²⁾

Symbol	Parameter	Min ⁽³⁾	Max	Unit
$t_w(CLK)$	FEMC_CLK period	$4t_{HCLK}$	-	ns
$t_{d(CLKL-NExL)}$	FEMC_CLK low to FEMC_NEx low	-	1.5	ns
$t_{d(CLKL-NExH)}$	FEMC_CLK low to FEMC_NEx high	2	-	ns
$t_{d(CLKL-NADVL)}$	FEMC_CLK low to FEMC_NADV low	-	2	ns
$t_{d(CLKL-NADVH)}$	FEMC_CLK low to FEMC_NADV high	3	-	ns
$t_{d(CLKL-AV)}$	FEMC_CLK low to FEMC_Ax valid	-	2	ns
$t_{d(CLKL-AIV)}$	FEMC_CLK low to FEMC_Ax invalid	2	-	ns
$t_{d(CLKL-NOEL)}$	FEMC_CLK low to FEMC_NOE low	-	1	ns
$t_{d(CLKL-NOEH)}$	FEMC_CLK low to FEMC_NOE high	1.5	-	ns

$t_{d(\text{CLKL-ADV})}$	FEMC_CLK low to FEMC_AD[15:0] valid	-	3	ns
$t_{d(\text{CLKL-ADIV})}$	FEMC_CLK low to FEMC_AD[15:0] invalid	0	-	ns
$t_{su(\text{ADV-CLKH})}$	FEMC_AD[15:0] valid before FEMC_CLK high	3	-	ns
$t_{h(\text{CLKH-ADV})}$	FEMC_AD[15:0] valid after FEMC_CLK high	2	-	ns
$t_{su(\text{NWAITV-CLKH})}$	FEMC_NWAIT valid before FEMC_CLK high	3	-	ns
$t_{h(\text{CLKH-NWAITV})}$	FEMC_NWAIT valid after FEMC_CLK high	3	-	ns

Notes:

(1) IO drive capacity is 8 mA, Capacitive load = 30 pF

(2) Measurement point set at CMOS level: 0.5VDD

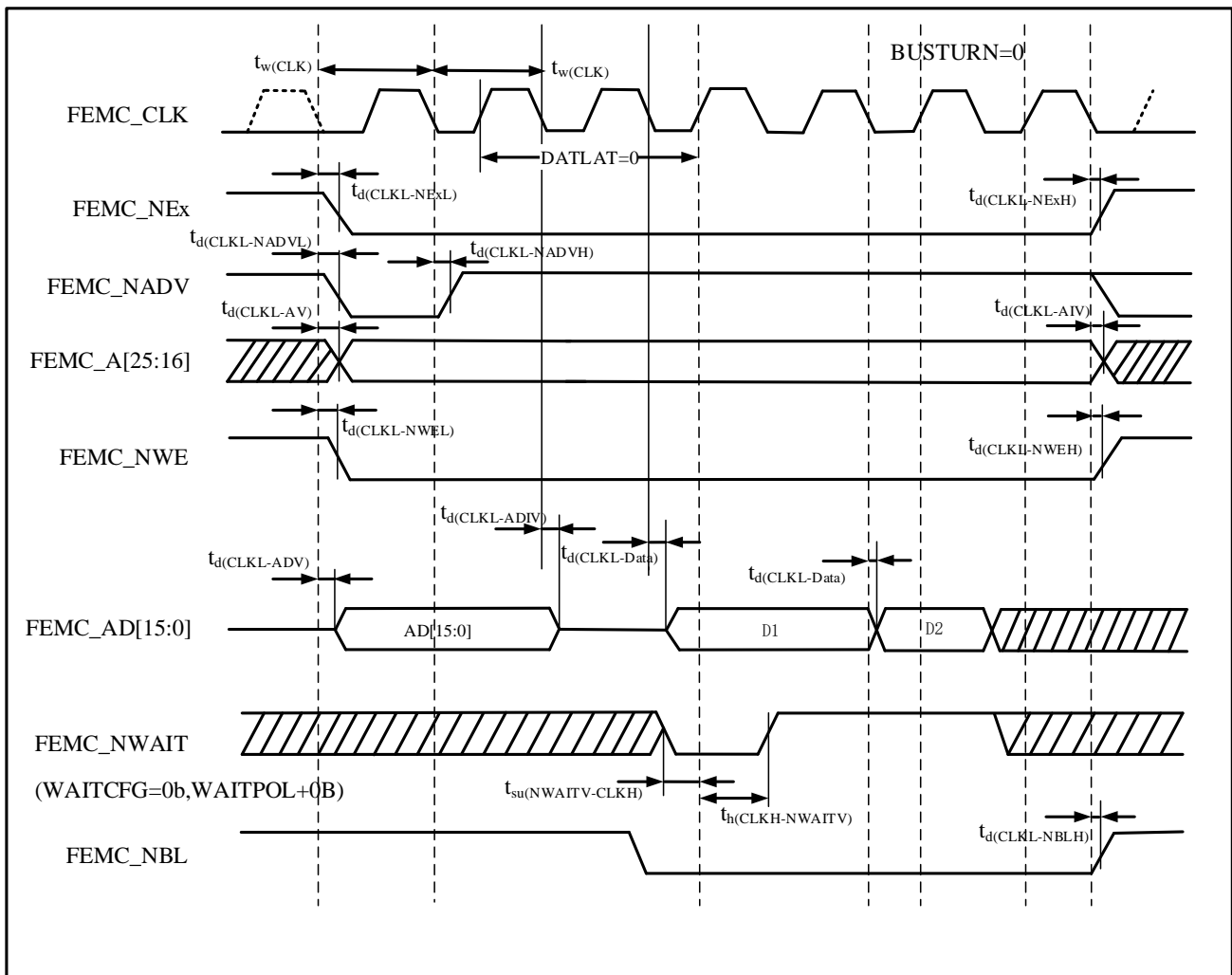
 (3) $t_{HCLK} \geq 1/240\text{MHz}$
Figure 4-28 Synchronous Multiplexed PSRAM Write Waveforms

Table 4-56 Synchronous Multiplexed NOR/PSRAM Write Timings⁽¹⁾⁽²⁾

Symbol	Parameter	Min ⁽³⁾	Max	Unit
$t_w(\text{CLK})$	FEMC_CLK period	$4t_{HCLK}$	-	ns
$t_{d(\text{CLKL-NExL})}$	FEMC_CLK low to FEMC_NEx low	-	1.5	ns
$t_{d(\text{CLKL-NExH})}$	FEMC_CLK low to FEMC_NEx high	2	-	ns

$t_{d}(\text{CLKL-NADV L})$	FEMC_CLK low to FEMC_NADV low	-	2	ns
$t_{d}(\text{CLKL-NADV H})$	FEMC_CLK low to FEMC_NADV high	3	-	ns
$t_{d}(\text{CLKL-AV})$	FEMC_CLK low to FEMC_Ax valid	-	3	ns
$t_{d}(\text{CLKL-AIV})$	FEMC_CLK low to FEMC_Ax invalid	2	-	ns
$t_{d}(\text{CLKL-NWEL})$	FEMC_CLK low to FEMC_NWE low	-	1	ns
$t_{d}(\text{CLKL-NWEH})$	FEMC_CLK low to FEMC_NWE high	1.5	-	ns
$t_{d}(\text{CLKL-ADV})$	FEMC_CLK low to FEMC_AD[15:0] valid	-	3	ns
$t_{d}(\text{CLKL-ADIV})$	FEMC_CLK low to FEMC_AD[15:0] invalid	0	-	ns
$t_{d}(\text{CLKL-Data})$	FEMC_AD[15:0] valid after FEMC_CLK low	-	3	ns
$t_{d}(\text{CLKL-NBLH})$	FEMC_CLK low to FEMC_NBL high	2	-	ns
$t_{su}(\text{NWAITV-CLKH})$	FEMC_NWAIT valid before FEMC_CLK high	3	-	ns
$t_{h}(\text{CLKH-NWAITV})$	FEMC_NWAIT valid after FEMC_CLK high	3	-	ns

Notes:

(1) IO drive capacity is 8 mA, Capacitive load = 30 pF

(2) Measurement point set at CMOS level: 0.5VDD

(3) $t_{HCLK} \geq 1/240\text{MHz}$

NAND controller waveforms and timings

Figure 4-29 through Figure 4-32 represent synchronous waveforms, and Table 4-57 provides the corresponding timings. The results shown in these tables are obtained with the following FEMC configuration:

- COM.FEMC_SetupTime = 0x01; (Note: SET of FEMC_NCMEMTM, x = 2...3)
- COM.FEMC_WaitSetupTime = 0x03; (Note: WAIT of FEMC_NCMEMTMxx, x = 2...3)
- COM.FEMC_HoldSetupTime = 0x02; (Note: HLD of FEMC_NCMEMTMxx, x = 2...3)
- COM.FEMC_HiZSetupTime = 0x01; (Note: HIZ of FEMC_NCMEMTMxx, x = 2...3)
- ATT.FEMC_SetupTime = 0x01; (Note: SET of FEMC_NATTMEMTMx, x = 2...3)
- ATT.FEMC_WaitSetupTime = 0x03; (Note: WAIT of FEMC_NATTMEMTMx, x = 2...3)
- ATT.FEMC_HoldSetupTime = 0x02; (Note: HLD of FEMC_NATTMEMTMx, x = 2...3)
- ATT.FEMC_HiZSetupTime = 0x01; (Note: HIZ of FEMC_NATTMEMTMx, x = 2...3)
- Bank = FEMC_Bank_NAND;
- MemoryDataWidth = FEMC_NAND_BUS_WIDTH_16B; (Note: Memory data width = 16)
- ECC = FEMC_NAND_ECC_ENABLE; (Note: Enable ECC)
- ECCPageSize = FEMC_NAND_ECC_PAGE_512BYTES; (Note: ECC page size = 512 kB)
- TCLRSetupTime = 0; (Note: CRDLY of FEMC_NCTRLx)
- TARSetupTime = 0; (Note: ARDLY of FEMC_NCTRLx)

Figure 4-29 NAND Controller Waveforms For Read Access

Figure 4-30 NAND Controller Waveforms For Write Access

Figure 4-31 NAND Controller Waveforms For Common Memory Read Access

Figure 4-32 NAND Controller Waveforms For Common Memory Write Access

Table 4-57 Timing Characteristics of NAND Flash Read/Write Cycles ⁽¹⁾

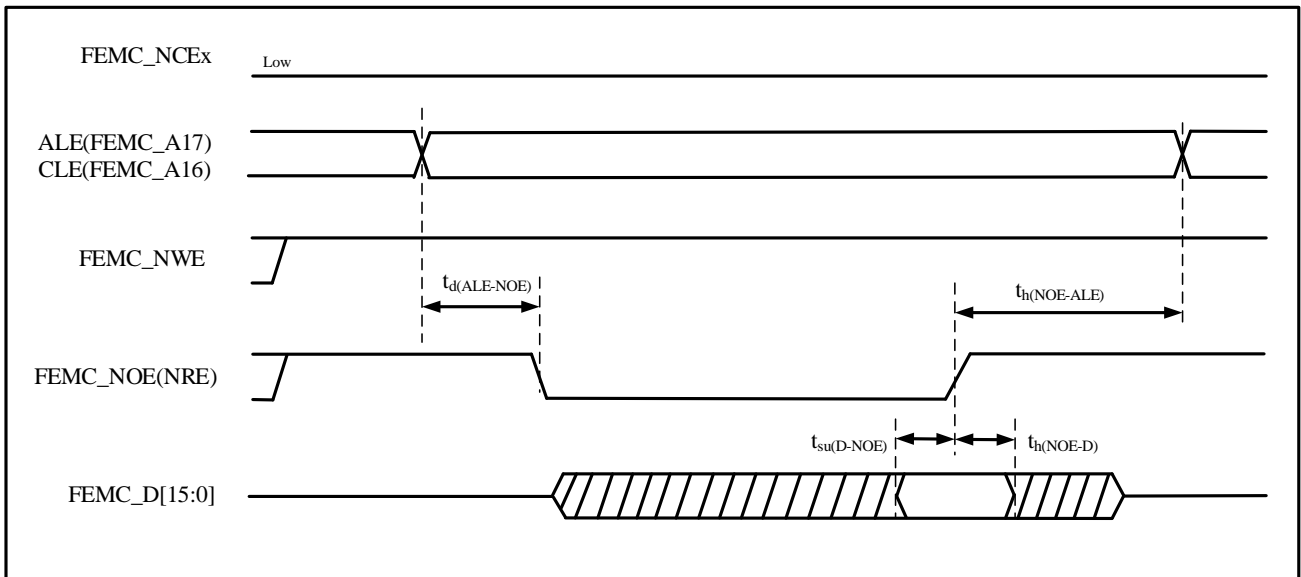
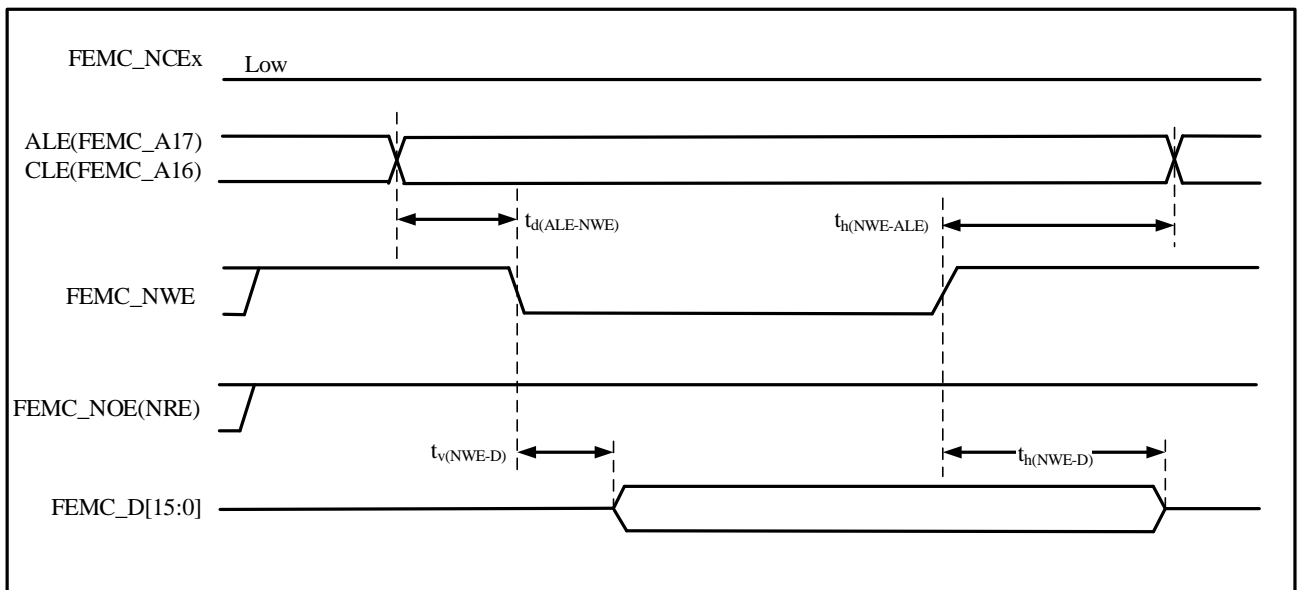
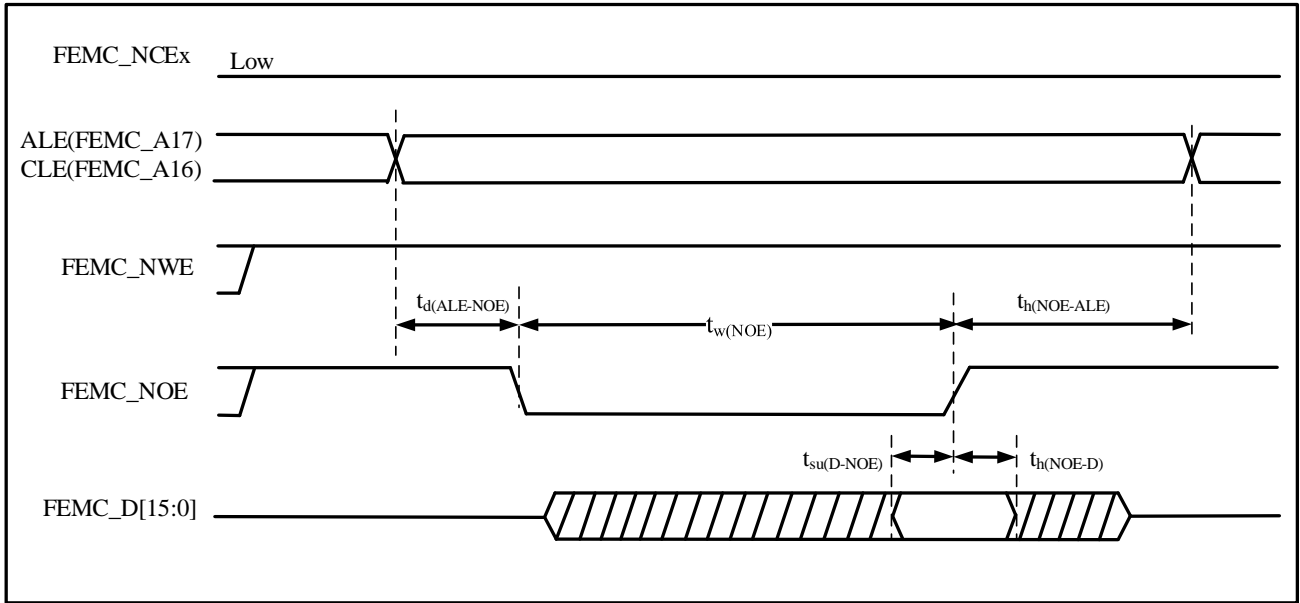
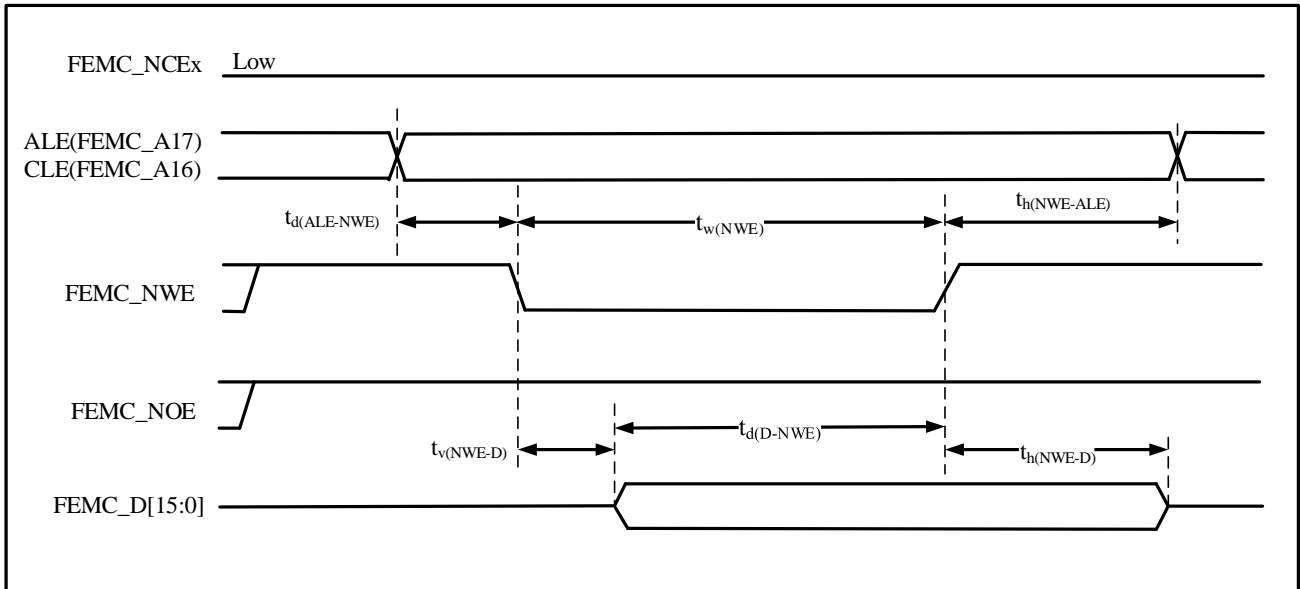
Symbol	Parameter	Min	Max	Unit
$t_{d(D-NWE)}$	Before FEMC_NWE high to FEMC_D[15:0] data valid	$5t_{HCLK} + 2$	-	ns
$t_{w(NOE)}$	FEMC_NOE low time	$4t_{HCLK} - 1.5$	$4t_{HCLK} + 1.5$	ns
$t_{su(D-NOE)}$ ³⁾	Before FEMC_NOE high to FEMC_D[15:0] data valid	6	-	ns
$t_{h(NOE-D)}$	After FEMC_NOE high to FEMC_D[15:0] data valid	2	-	ns
$t_{w(NWE)}$	FEMC_NWE low time	$4t_{HCLK} - 1$	$4t_{HCLK} + 1$	ns
$t_{v(NWE-D)}$	FEMC_NWE low to FEMC_D[15:0] data valid	-	0	ns
$t_{h(NWE-D)}$	FEMC_NWE high to FEMC_D[15:0] data invalid	$2t_{HCLK} + 3$	-	ns
$t_{d(ALE-NWE)}$	FEMC_NWE low to FEMC_ALE valid	-	$3t_{HCLK} + 1.5$	ns

$t_{h(NWE-ALE)}$	FEMC_NWE high to FEMC_ALE invalid	$3t_{HCLK} + 2$	-	ns
$t_{d(ALE-NOE)}$	Before FEMC_NOE low to FEMC_ALE valid	-	$3t_{HCLK} + 2$	ns
$t_{h(NOEALE)}$	FEMC_NOE high to FEMC_ALE invalid	$3t_{HCLK} + 3$	-	ns

Note:(1) Capacitive load = 15 pF.

4.3.21 USB_FS_Device Characteristics

USB (full speed) interface is certified by the USB-IF.

Table 4-58 USBFS Startup Time

Symbol	Parameter	Max	Unit
$t_{STARTUP}^{(1)}$	USB transceiver startup time	1	μs

Note: (1)Guaranteed by design, not tested in production.

Table 4-59 USBFS DC Characteristics

Symbol	Parameter	Condition	Min ⁽¹⁾	Max ⁽¹⁾	Unit
Input level					
V_{DD}	USB operating voltage ⁽²⁾		3.0 ⁽³⁾	3.6	V
$V_{DI}^{(4)}$	Differential input sensitivity	I (USBDP and USBDM)	0.2	-	V
$V_{CM}^{(4)}$	Differential common mode range	Contains V_{DI} ranges	0.8	2.5	
$V_{SE}^{(4)}$	Single-end receiver threshold		1.3	2.0	
Output level					
V_{OL}	Static output low level	1.5K Ω RL is connected to 3.6V ^{(5) (6)}	-	0.3	V
V_{OH}	Static output high level	15K Ω RL is connected to $V_{SS}^{(6)}$	2.8	3.6	

Notes:

(1)All voltage measurements are based on the ground cable at the device end.

(2)USB operating voltage is 3.0~3.6V in order to be compatible with USB2.0 full speed electrical specification.

(3)The correct USB function of the N32H474 series products can be guaranteed at 2.7V, instead of dropping the electrical characteristics in the 2.7-3.0V voltage range.

(4)Based on comprehensive evaluation, not tested in production.

(5)The chip has a built-in 1.5k Ω pull-up resistor, which is optional for the user.

(6) R_L is the load attached to the USB drive.

Figure 4-33 USB Timing: Definition Of Rise And Fall Time Of Data Signal

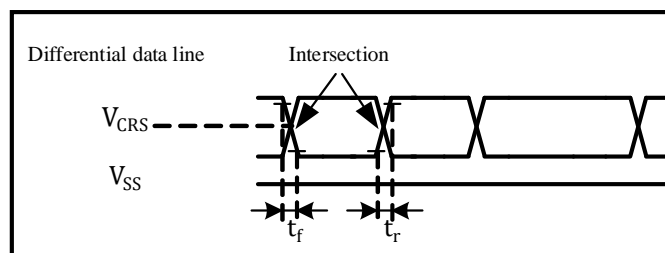

Table 4-60 Full Speed Of USB Electrical Characteristics

Symbol	Parameter	Condition	Min ⁽¹⁾	Max ⁽¹⁾	Unit
t_r	Rise time ⁽²⁾	$CL \leq 50pF$	4	20	ns
t_f	Fall time ⁽²⁾	$CL \leq 50pF$	4	20	ns
t_{rfm}	Rise and fall times match	t_r / t_f	90	110	%
V_{CRS}	Output signal crosstalk ⁽³⁾	-	1.3	2.0	V

Notes:

(1)Guaranteed by design, not tested in production.

(2)Measured data signal from 10% to 90%.For more details, see Chapter 7 (version 2.0) of the USB specification.

(3)External terminal series resistors are not required on USB_PD (D+) and USB_DM (D-); matching impedance is included in the embedded driver.

4.3.22 Controller Area Network (CAN) Interface Characteristics

See Section 4.3.12 for details on the features of the input/output alternate function pins (CAN_TX and CAN_RX).

4.3.23 12 bit Analog-to-Digital Converter (ADC) Electrical Parameters

Unless otherwise specified, the parameters in **Table 4-61** are measured using ambient temperature, f_{HCLK} frequency, and V_{DDA} supply voltage in accordance with the conditions in **Table 4-4**.

Note: It is recommended to perform a calibration at each power-on.

Table 4-61 ADC Characteristics

Symbol	Parameter	Condition	Min	Typ	Max	Unit
V_{DDA}	The power supply voltage	-	1.8	-	3.6	V
V_{REF+}	Positive reference voltage	-	1.8	-	V_{DDA}	V
f_{ADC}	ADC clock frequency	-	-	-	80	MHz
f_s	Sampling rate ⁽¹⁾	$V_{DDA} \geq 2.4V$	-	-	4.7	MSPS
		$1.8V \leq V_{DDA} < 2.4V$	-	-	4	
V_{AIN}	Switching voltage range ⁽²⁾	-	0(V_{SSA} or V_{REF-} connect to ground)		V_{REF+}	V
R_{ADC}	Sampling Switch Resistor	2.4~3.3V	-	-	300	ohm
		1.8~2.4V	-	-	480	
C_{ADC}	Internal sampling and holding capacitors	-	-	5	-	pF
SNDR	Singal noise distortion ration	-	-	65	-	dBFS
T_{cal}	The calibration time	-	82			$1/f_{ADC}$
t_s	Sampling time	$f_{ADC} = 80$ MHz(fast channel)	0.0563	-	7.52	μs
		$f_{ADC} = 80$ MHz(slow channel)	0.0938	-	7.52	
T_s		$f_{ADC} = 80$ MHz(fast channel)	4.5	-	601.5	$1/f_{ADC}$
		$f_{ADC} = 80$ MHz(slow channel)	7.5	-	601.5	
t_{STAB}	Power on time	-	0	0	20	μs
$t_{CONV}^{(2)}$	Total conversion time (including sampling time)	-	14~614 (Sampling T_s + 12.5 for successive approximation)			$1/f_{ADC}$

Notes:

(1)Guaranteed by design, not tested in production.

(2)According to different packages, V_{REF+} connected to V_{DDA} internally, and V_{REF-} connected to V_{SSA} internally.

(3) The sampling time/sampling rate is related to the input impedance R_{in} , and the specific correspondence between the maximum input impedance R_{in} and the sampling time can be found in Table 4-62.

Table 4-62 ADC Sampling Time⁽¹⁾

Resolution	Rin (kΩ)	Minimum Sampling Time (ns)			
		Vdda=2.4V to 3.6V, Vddd=1.1 V, selrange_ldo=L, Tjunction=125 °C, fclk=80 MHz		Vdda=1.8V to 2.4V, Vddd=1.1 V, selrange_ldo=L, Tjunction=125 °C, fclk=80 MHz.	
		Fast Channel	Slow Channel	Fast Channel	Slow Channel
12-bit	0.14	45.0	73.0	79.0	103.0
	0.6	79.0	103.0	300.0	345.0
	4.6	300.0	345.0	576.0	651.0
	9.5	576.0	651.0	1131.0	1257.0
	19	1131.0	1257.0	2776.0	3051.0
	48	2776.0	3051.0	5475.0	5982.0
10-bit	0.14	39.0	61.0	64.0	88.0
	0.6	64.0	88.0	250.0	357.0
	4.6	250.0	357.0	478.0	540.0
	9.5	478.0	540.0	935.0	1040.0
	19	935.0	1040.0	2294.0	2526.0
	48	2294.0	2526.0	4532.0	4963.0
8-bit	0.14	33.0	50.0	52.0	71.0
	0.6	52.0	71.0	202.0	234.0
	4.6	202.0	234.0	391.0	457.0
	9.5	391.0	457.0	800.0	1012.0
	19	800.0	1012.0	1838.0	2027.0
	48	1838.0	2027.0	3632.0	3984.0
6-bit	0.14	27.0	40.0	41.0	56.0
	0.6	41.0	56.0	153.0	177.0
	4.6	153.0	177.0	292.0	330.0
	9.5	292.0	330.0	569.0	642.0
	19	569.0	642.0	1435.0	1666.0
	48	1435.0	1666.0	3001.0	3919.0

Notes:

(1)Guaranteed by design, not tested in production.

Table 4-63 ADC Accuracy-Limited Test Conditions⁽¹⁾⁽²⁾⁽⁴⁾

Symbol	Parameter	Condition	Typ	Max ⁽³⁾	Unit
ET	Comprehensive error	f _{HCLK} = 200 MHz, f _{ADC} = 200 MHz, sample rate=1.75M sps, sigle ended, V _{DDA} = 3.3V, T _A = 25 °C Measurements are made after the ADC is calibrated V _{REF+} = V _{DDA}	1.3	5	LSB
EO ⁽⁴⁾	Offset error		1	3	
ED	Differential linear error		1	2.2	
EL	Integral linear error		2	3	

Notes:

(1)The DC accuracy of the ADC is measured after internal calibration.

(2)ADC accuracy versus reverse injection current: It is necessary to avoid injecting reverse current on any standard analog input pin, as this can significantly reduce the accuracy of the conversion being performed on the other analog input pin.It is recommended to add a Schottky diode (between pin and ground) to standard analog pins that may generate reverse injection current.

(3)The forward injection current does not affect the ADC accuracy as long as it is within the range of I_{INJ(PIN)} and ΣI_{INJ(PIN)} given in Table 4-2

(4)Based on comprehensive evaluation, not tested in production.

Figure 4-34 ADC Precision Characteristics

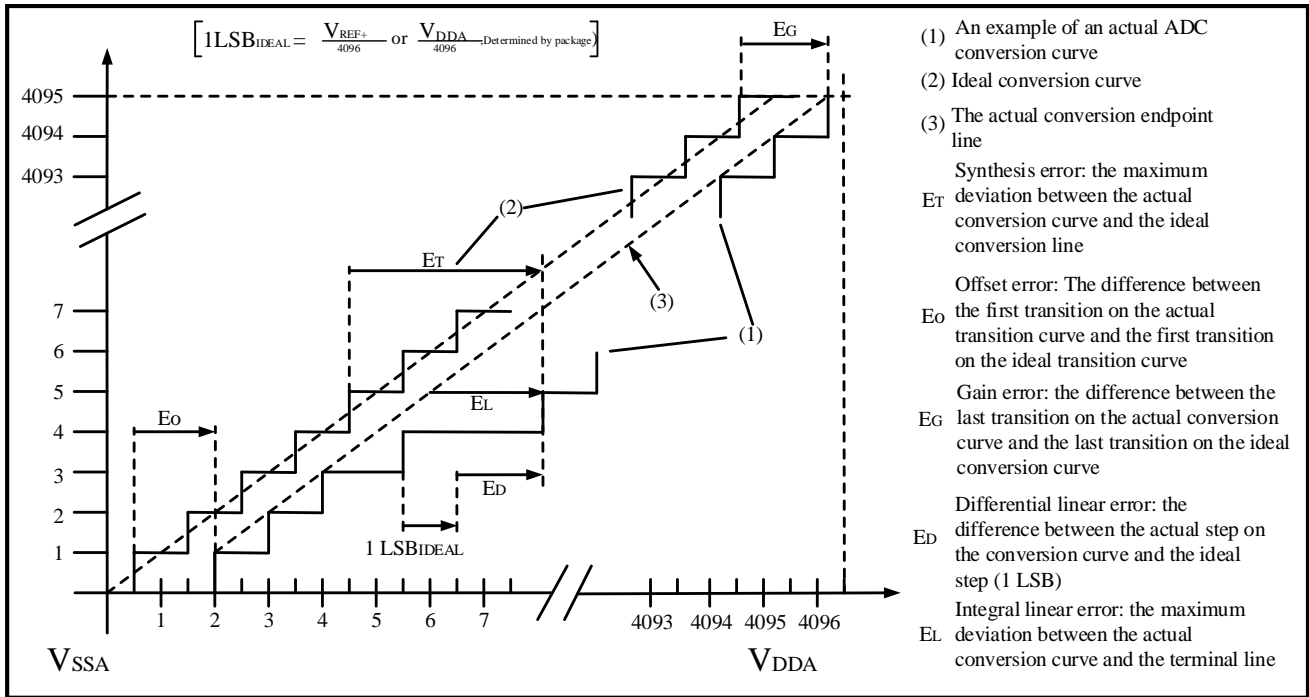
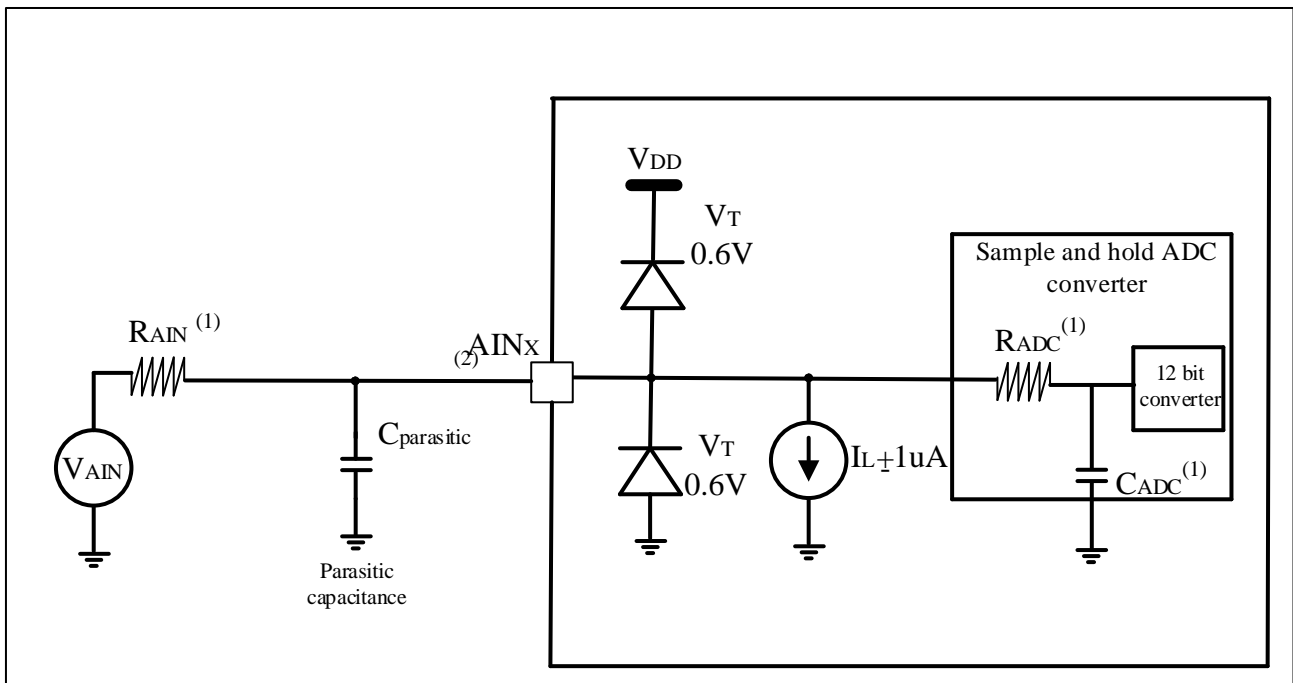

Figure 4-35 Typical Connection Diagram Using ADC



Notes:

(1)For values of R_{AIN} , R_{ADC} , and C_{ADC} , see Table 4-61.

(2) $C_{parasitic}$ indicates parasitic capacitance on PCB (related to welding and PCB layout quality) and pads (approximately 7pF). A larger $C_{parasitic}$ value would reduce the accuracy of the conversion and the solution was to reduce f_{ADC} from medine.

4.3.24 12-bit Digital-to-Analog Converter (DAC) Electrical Parameters

Unless otherwise specified, the parameters of **Table 4-64** are measured using ambient temperature, f_{HCLK} frequency, and V_{DDA} supply voltage in accordance with the conditions of **Table 4-4**.

Table 4-64 DAC 1MSPS Characteristics

Symbol	Parameter	Condition	Min	Typ	Max	Unit
V_{DDA}	Analog supply voltage	DAC output buffer disabled, output only internally connected	2.4	-	3.6	V
V_{REF+}	Positive reference voltage	DAC output buffer disabled, output only internally connected	2.4	-	V_{DDA}	
V_{REF-}	Negative reference voltage	-	VSSA			
R_L	Resistive load with buffer enable	DAC output Buffer enable	5	-	-	k Ω
		Connected to VSSA	25	-	-	
R_o	Impedance output	DAC output buffer disable	10.3	12.3	15.7	k Ω
C_L	Capacitive load	-	-	-	50	pF
DAC_OUT	DAC_OUT output voltage	Output buffer enable	0.2	-	$V_{REF+} - 0.2$	V
		Output buffer disable	0	-	V_{REF+}	-
I_{DD}	Static mode (standby mode) DAC DC consumption ($V_{DD3}+V_{DDA}+V_{REF+}$)	-	-	180	230	μ A
		-	-	400	610	μ A
$t_{SETTLING}$	Settling time (full range: 12-bit input code transitioning from minimum value to maximum value, DAC_OUT reaching its final value within ± 1 LSB)	DAC buffer enable, $C_L \leq 50$ pF, $R_L \geq 5$ k Ω	-	3	4.1	μ s
		DAC buffer disable	-	2.1	2.6	
t_{WAKEUP}	Wake-up time from shutdown state (from enabling DAC to DAC_OUT reaching its final value within ± 1 LSB)	DAC buffer enable, $C_L \leq 50$ pF, $R_L \geq 5$ k Ω	-	4	7	μ s
		DAC buffer disable, $C_L \leq 10$ pF	-	2	4	
PSRR	Power supply rejection ratio (relative to V_{DD33A}) (static DC measurement)	DAC buffer enable, $C_L \leq 50$ pF, $R_L \geq 5$ k Ω	-	-85	-30	dB
TW_to_W	The minimum time between two consecutive writes to the DACx_DATO register to ensure that small changes in the input code result in the correct DAC_OUT(1 LSB). DACxy_CTRL.EXOUT = 1, DACxy_CTRL.BxEN = 1	$C_L \leq 50$ pF, $R_L \geq 5$ k Ω	1	-	-	μ s
		$C_L \leq 10$ pF	1.4	-	-	
Voffset	Middle code offset for 1 trim code step	$V_{REF+} = 3.6V$	-	-	1500	μ V

I _{DDA(DAC)}	DAC consumption from V _{DDA}	DAC buffer enable	No load, input mid-value 0x800	-	250	400	μA
			No load, input max-value 0xF1C	-	450	670	
		DAC buffer disable	No load, input mid-value 0x800	-	-	0.25	
I _{DDV(DAC)}	DAC consumption from V _{REF+}	DAC buffer enable	No load, input mid-value 0x800	-	180	240	μA
			No load, input max-value 0xF1C	-	320	400	
		DAC buffer disable	No load, input mid-value 0x800	-	155	200	
DNL	Nonlinear distortion (deviation between two consecutive codes)	-	-2	-	+2	LSB	
INL	Nonlinear accumulation (deviation measured at code i from the line connecting code 0 and code 4095)	-	-6	-	+6	LSB	
Offset	Offset error (value measured at code 0x800)	Output buffer enable, CL ≤ 50 pF, RL ≥ 5 kΩ	V _{REF+} = 3.6V	-16	-	+8	LSB
			V _{REF+} = 1.8V	-20	-	+20	
		Output buffer disable, CL ≤ 50 pF, no RL	-8	-	+6		
Gain Error	Gain error	-	-	±0.5	-	%	

Note: (1)Guaranteed by design, not tested in production.

Table 4-65 DAC 15MSPS Characteristics

Symbol	Parameter	Condition	Min	Typ	Max	Unit	
V _{DDA}	Analog supply voltage	-	1.8	-	3.6	V	
V _{REF+}	Positive reference voltage	-	1.8	-	3.6	V	
V _{REF-}	Negative reference voltage	-	V _{SSA}			V	
DAC _{OUT}	DAC _{OUT} output voltage	-	0	-	V _{REF+}	V	
DNL	Nonlinear distortion (deviation between two consecutive codes)	-	-2	-	2	LSB	
INL	Nonlinear accumulation (deviation measured at code i from the line connecting code 0 and code 4095)	CL ≤ 50 pF, no RL	-4	-	+4	LSB	
t _{SETTLING}	Settling time (full range: 10-bit input code transitioning from minimum value to maximum value, DAC _{OUT} reaching its final value within ±1 LSB)	V _{DD} > 2.7 With One comparator on DAC output	10%-90%	-	16	22	ns
			5%-95%	-	21	29	
			1%-99%	-	33	46	
			32lsb	-	40	53	
			1lsb	-	64	87	
		V _{DD} > 2.7 With One comparator and PGA on DAC output	10%-90%	-	24	32	
			5%-95%	-	32	43	
			1%-99%	-	49	67	
			32lsb	-	57	75	
			1lsb	-	93	125	
		V _{DD} < 2.7 With One comparator on DAC output	10%-90%	-	17	88	
			5%-95%	-	21	116	
			1%-99%	-	33	181	
			32lsb	-	40	196	
1lsb	-		64	332			
V _{DD} < 2.7	10%-90%	-	24	128			

		With One comparator and PGA on DAC output	5%-95%	-	32	170	
			1%-99%	-	49	265	
			32lsb	-	57	284	
			1lsb	-	93	483	
t_{WAKEUP}	Wake-up time from shutdown state (from enabling DAC to DAC_OUT reaching its final value within ± 1 LSB)	$CL \leq 10$ pF		-	1.4	3.5	μs
PSRR	Power supply rejection ratio	$VDD > 2.7$ V		66	85	-	dB
		$VDD < 2.7$ V		54	85	-	dB
$I_{DDA(DAC)}$	DAC consumption from VDDA	No load, middle code (0x800)		-	-	0.2	μA
$I_{DDV(DAC)}$	DAC consumption from VREF+	No load, middle code (0x800)		-	720	1066	

Note: (1) Guaranteed by design, not tested in production.

4.3.25 Comparator (COMP) Characteristics

Unless otherwise specified, the parameters in Table 4-66 are measured using ambient temperature, f_{HCLK} frequency, and V_{DDA} supply voltage in accordance with the conditions in Table 4-4.

Table 4-66 Comparator Characteristics

Symbol	Parameter	Condition	Min	Typ	Max	Unit	
V_{DDA}	Analog supply voltage	-	1.8	-	3.6	V	
V_{IN}	Comparator input voltage range	-	0	-	V_{DDA}		
V_{REF}	6bit DAC offset voltage	DAC middle output, $V_{REFP} = 3.3V$	-	± 5	± 12	mV	
I_{REF}	6bit DAC static consumption from V_{REFP}	DAC middle output, $V_{REFP} = 3.3V$	-	270	350	nA	
		DAC maximum output, $V_{REFP} = 3.3V$	-	360	470	μA	
T_{START}	Comparator startup time	-	-	-	5	μs	
t_D	Propagation delay for 200 mV step with 100 mV overdrive	50pF load on output	$V_{DDA} \geq 2.4$	-	22	35	ns
			$V_{DDA} < 2.4V$	-	-	40	ns
V_{OFFSET}	Comparator input offset error	Full common mode range	-6	-	6	mV	
V_{HYS}	Comparator hysteresis	$HYST[2:0] = 0$	-	0	-	mV	
		$HYST[2:0] = 1$	5	10	16		
		$HYST[2:0] = 2$	11	20	29		
		$HYST[2:0] = 3$	15	30	42		
		$HYST[2:0] = 4$	20	40	58		
		$HYST[2:0] = 5$	25	50	72		
		$HYST[2:0] = 6$	31	60	86		
I_{DDA}	Comparator consumption from VDDA	Static	-	450	720	μA	
		With 50 kHz ± 100 mV overdrive square signal	-	450	-		

Note: (1) Guaranteed by design, not tested in production.

4.3.26 Programmable Gain Amplifier (PGA) Characteristics

Unless otherwise specified, the parameters in Table 4-67 and Table 4-68 are measured using ambient temperature, f_{HCLK} frequency, and V_{DDA} supply voltage in accordance with the conditions in Table 4-4.

Table 4-67 PGA Characteristics in Single-Ended Mode⁽¹⁾

Symbol	Parameter	Condition	Min	Typ	Max	Unit
V _{DDA}	Analog supply voltage	-	2	-	3.6	V
V _{AIN}	Input voltage range	-	0	-	V _{DDA}	V
V _{OUT}	Output voltage range	-	0.3	-	V _{DDA} -0.3	V
R _{IN}	Input resistance	-	-	10	-	MΩ
G	Single-ended gain	-	1, 2, 4, 8, 12, 16, 24, 32			-
E _{GAIN}	Gain error	G = 1	-1	-	1	%
		G = 32	-5	-	5	%
V _{OS}	Offset	-	-3	-	3	mV
T _{OFFSET}	Offset temperature drift	-	-	5	-	uV/°C
SR	Slew rate	Sampling capacitance for the ADC load	-	22	-	V/us
GBW	Gain Bandwidth Product	G = 1	-	50	-	MHz
		G = 8	-	7.5	-	
		G = 32	-	2.2	-	
t _{SETTLE}	Setup time	G = 1	-	170	220	ns
		G = 8	-	400	600	
		G = 32	-	1400	2000	
SNR	Signal-to-Noise Ratio	G = 1, Fin = 10KHz, Amp = 0.94Fs, N = 2048	-	80	-	dB
THD	Total Harmonic Distortion		-	-80	-	dB
ENOB	Effective Bits		-	13	-	bit
SFDR	Spurious-Free Dynamic Range		-	90	-	dB
SNR	Signal-to-Noise Ratio	G = 32, Fin = 10KHz, Amp = 0.94Fs, N = 2048	-	72	-	dB
THD	Total Harmonic Distortion		-	-80	-	dB
ENOB	Effective Bits		-	10	-	bit
SFDR	Spurious-Free Dynamic Range		-	68	-	dB
I	Power Consumption	Single PGA	-	-	4.3	mA

Note: (1) Guaranteed by design, not tested in production.

Table 4-68 PGA Characteristics in Differential Mode⁽¹⁾

Symbol	Parameter	Condition	Min	Typ	Max	Unit
V _{DDA}	Analog supply voltage	-	2	-	3.6	V
V _{AIN}	Input voltage range	-	0	-	V _{DDA}	V
V _{OUT}	Output voltage range	-	0.1	-	V _{DDA} -0.1	V
R _{IN}	Input resistance	-	-	10	-	MΩ
G	Single-ended gain	-	2, 4, 8, 16, 24, 32, 48, 64			-
E _{GAIN}	Gain error	G = 2	-0.5	-	0.5	%
		G = 64	-3	-	3	%
V _{OS}	Offset	-	-3	-	3	mV
T _{OFFSET}	Offset temperature drift	-	-	5	-	uV/°C
SR	Slew rate	Sampling capacitance for the ADC load	-	44	-	V/us
GBW	Gain Bandwidth Product	G = 2	-	25	-	MHz
		G = 16	-	3.7	-	

		G = 64	-	1.1	-	
t _{SETTLE}	Setup time	G = 2	-	170	220	ns
		G = 16	-	400	600	
		G = 64	-	1400	2000	
SNR	Signal-to-Noise Ratio	G = 2, Fin = 10KHz, Amp = 0.94Fs, N =2048	-	81	-	dB
THD	Total Harmonic Distortion		-	-79	-	dB
ENOB	Effective Bits		-	13.2	-	bit
SFDR	Spurious-Free Dynamic Range		-	90	-	dB
SNR	Signal-to-Noise Ratio	G = 64, Fin = 10KHz, Amp = 0.94Fs, N =2048	-	73	-	dB
THD	Total Harmonic Distortion		-	-66	-	dB
ENOB	Effective Bits		-	10	-	bit
SFDR	Spurious-Free Dynamic Range		-	68	-	dB
I	Power Consumption	Single PGA	-	-	6.4	mA

Note: (1)Guaranteed by design, not tested in production.

4.3.27 Voltage Reference Buffer (VREFBUF) Characteristics

Unless otherwise specified, the parameters in **Table 4-69** are measured using ambient temperature, f_{HCLK} frequency, and V_{DDA} supply voltage in accordance with the conditions in **Table 4-4**.

Table 4-69 VREFBUF Characteristics⁽¹⁾

Symbol	Parameter	Condition	Min	Typ	Max	Unit
V _{DDA}	Analog supply voltage	-	2.4	-	3.6	V
V _{REFBUF_OUT}	Voltage reference output	VRS= 00, T _A =25°C	2.044	2.048	2.052	
		VRS= 01, T _A =25°C	2.496	2.5	2.504	
		VRS= 10, T _A =25°C	2.896	2.9	2.904	
TRIM	Trim step resolution	-	-	±0.05	±0.1	%
CL	Load capacitor	-	0.5	1	2	µF
PSRR	Power supply rejection	DC	48.9	74.7	-	dB
		100KHz	25	40	-	
t _{START}	Start-up time	CL =1 µF	-	500	650	µs
I _{DDA(VREFBUF)}	VREFBUF consumption from VDDA	I _{load} ≤ 10 mA	-	45	80	µA

Note: (1)Guaranteed by design, not tested in production.

4.3.28 Temperature Sensor (TS) Characteristics

Unless otherwise specified, the parameters in **Table 4-70** are measured using ambient temperature, f_{HCLK} frequency, and V_{DDA} supply voltage in accordance with the conditions in **Table 4-4**.

Table 4-70 Temperature Sensor Characteristics

Symbol	Parameter	Min	Typ	Max	Unit
T _L ⁽¹⁾⁽⁴⁾	V _{SENSE} linearity with temperature	-	±1	±3	°C
Avg_Slope ⁽¹⁾	Average slope	-3.7	-4	-4.3	mV/°C

Symbol	Parameter	Min	Typ	Max	Unit
$V_{25}^{(1)}$	Voltage at 25 °C	-	1.32	-	V
$t_{START}^{(1)}$	Startup time	4	-	10	μs
$T_{S_temp}^{(2)(3)}$	ADC sampling time when reading the teperature	-	-	3	μs

Notes:

(1)Based on comprehensive evaluation, not tested in production.

(2)Guaranteed by design, not tested in production.

(3)Shortest sampling time can be determined in the application by multiple iterations.

(4)The temperature sensor measures the junction temperature of the chip, not the ambient temperature.

5 Packages

5.1 QFN32

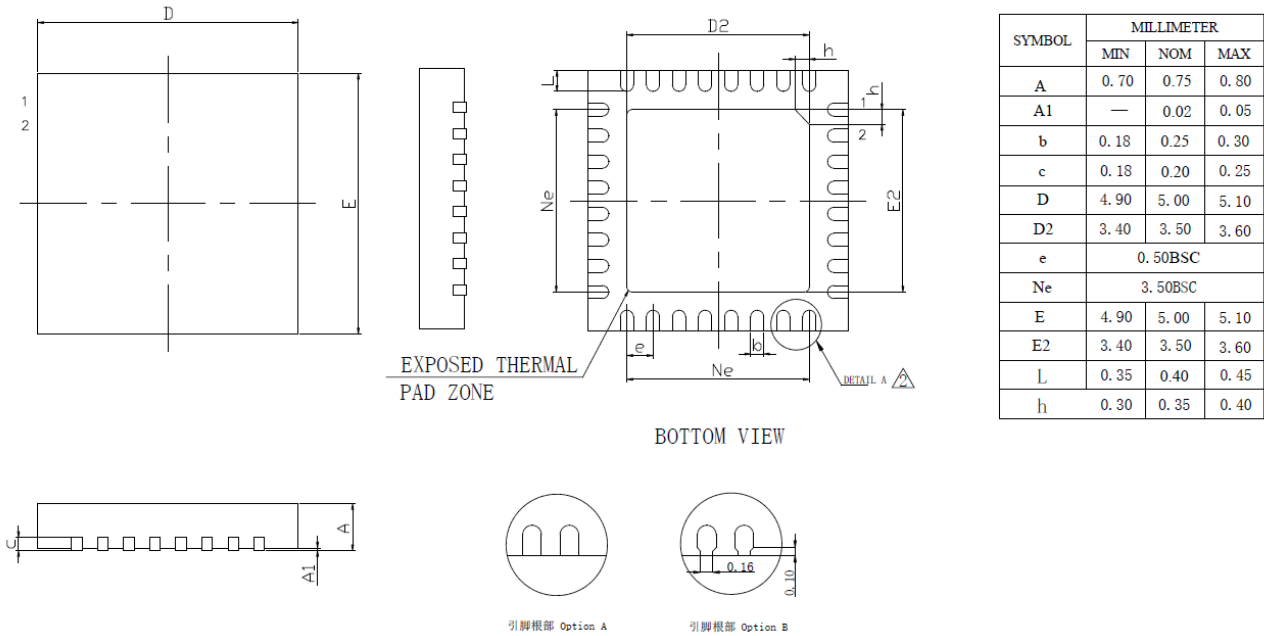
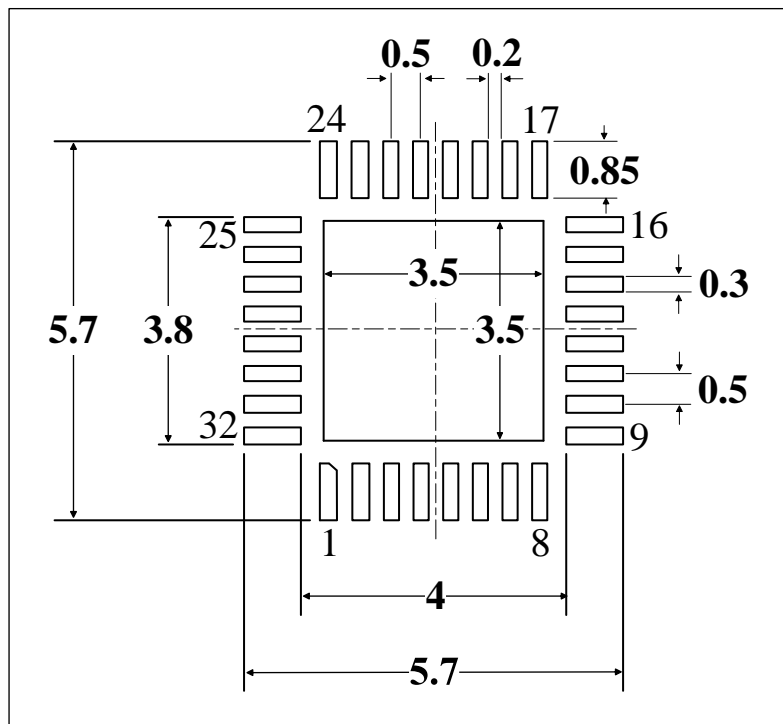
Figure 5-1 QFN32 Package Dimensions

Figure 5-2 QFN32 Recommended Footprint⁽¹⁾

1. Dimensions are expressed in millimeters

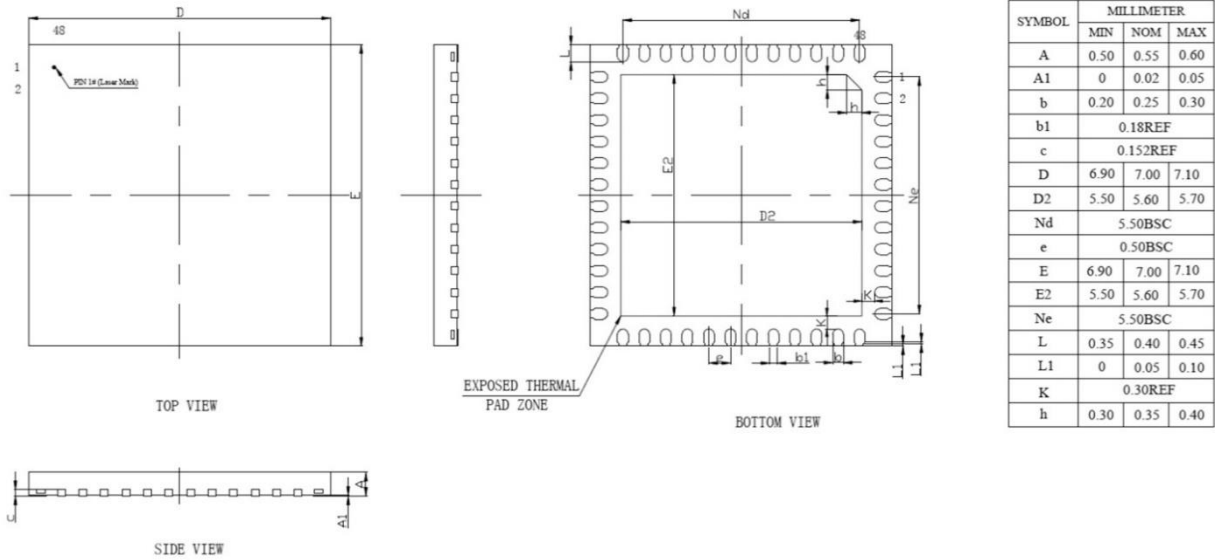
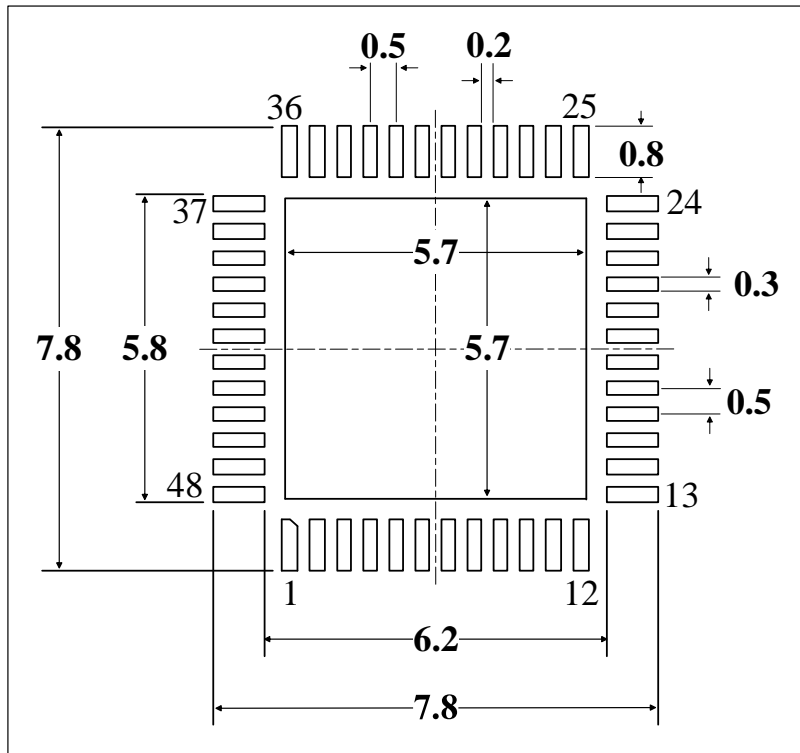
5.2 UQFN48

Figure 5-3 UQFN48 Package Dimensions

Figure 5-4 UQFN48 Recommended Footprint⁽¹⁾

1. Dimensions are expressed in millimeters

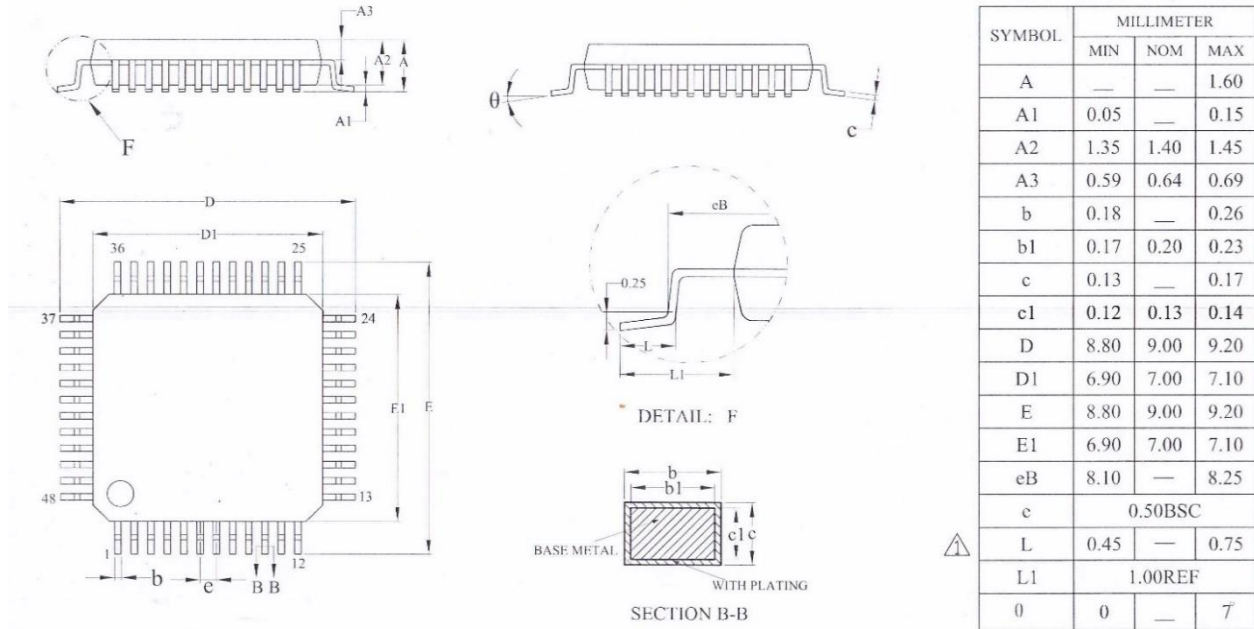
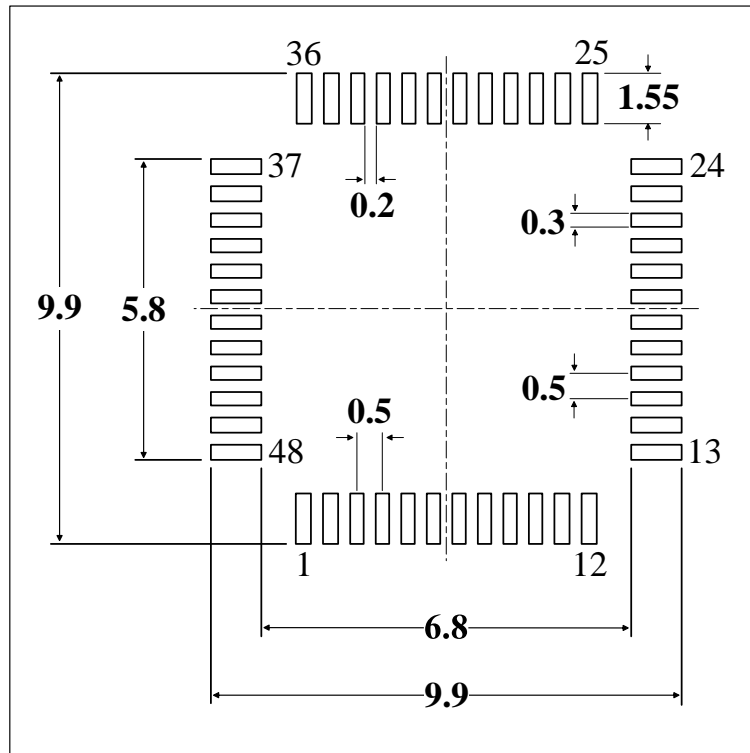
5.3 LQFP48

Figure 5-5 LQFP48 Package Dimensions

Figure 5-6 LQFN48 Recommended Footprint⁽¹⁾

1. Dimensions are expressed in millimeters

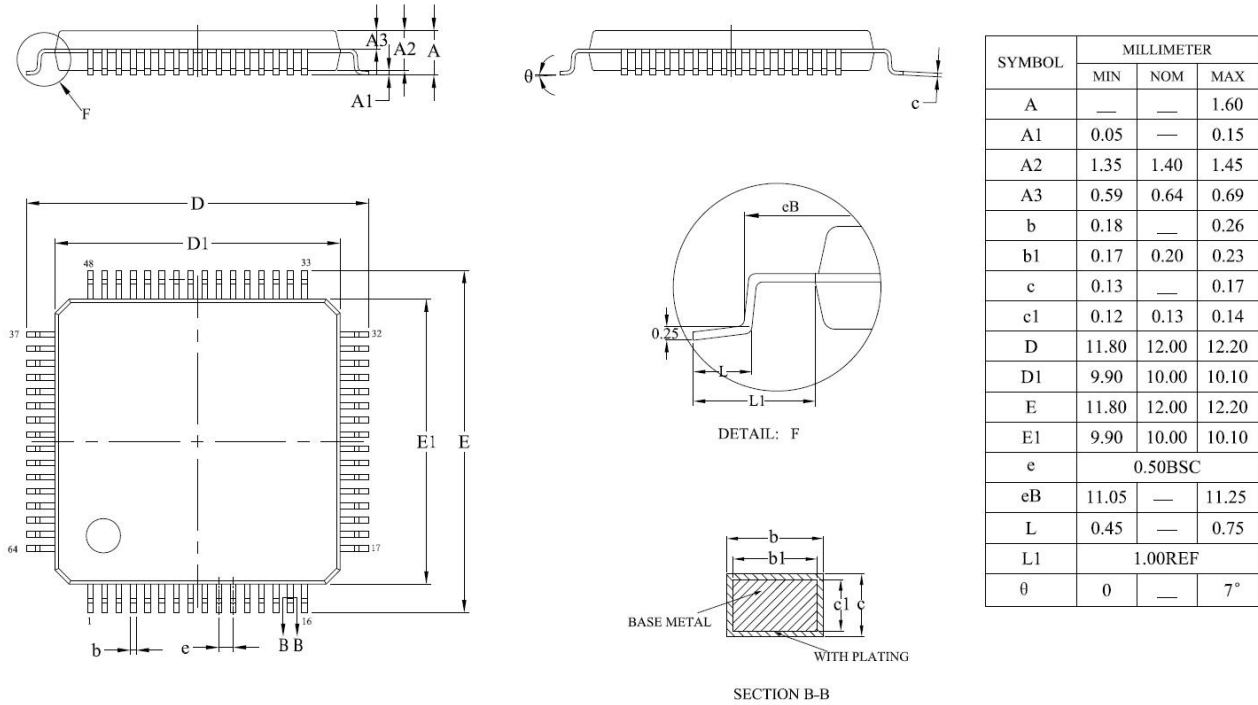
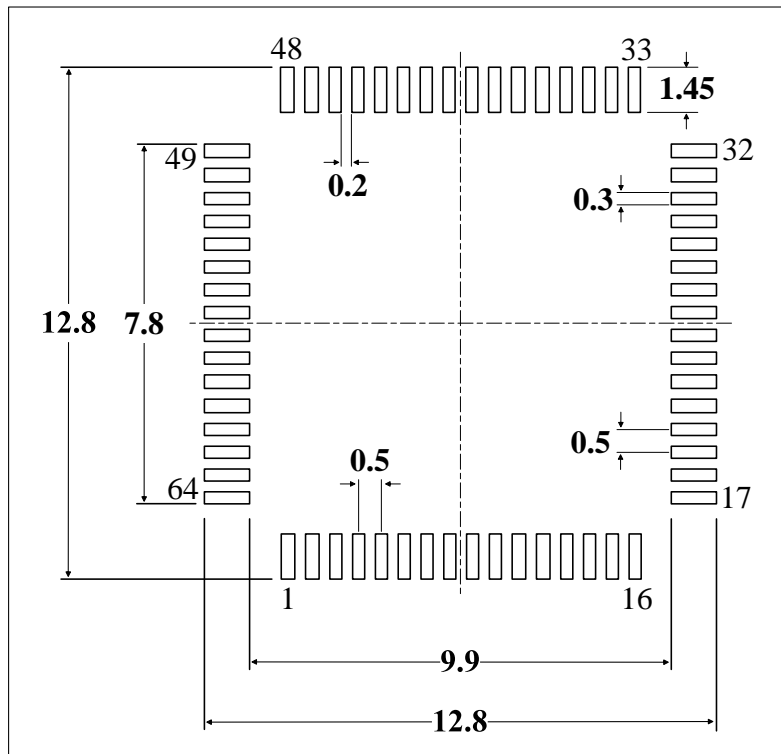
5.4 LQFP64

Figure 5-7 LQFP64 Package Dimensions

Figure 5-8 LQFN64 Recommended Footprint⁽¹⁾

1. Dimensions are expressed in millimeters

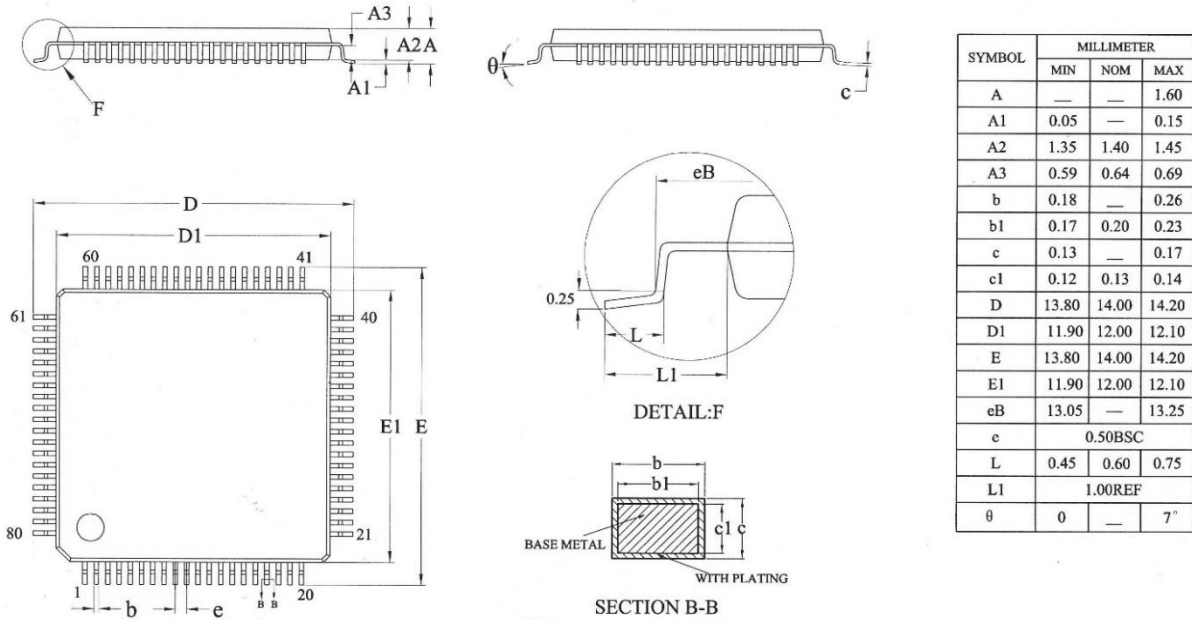
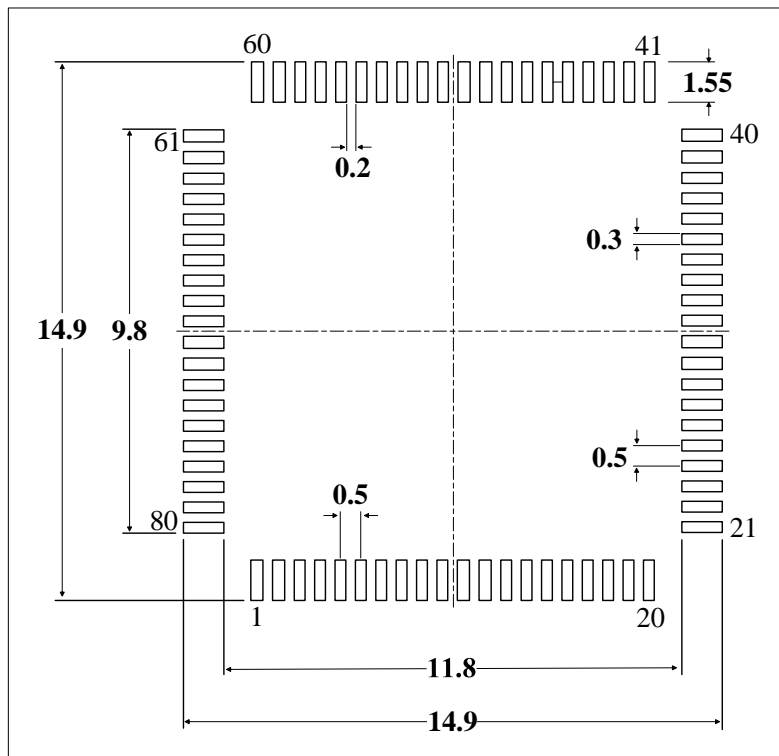
5.5 LQFP80

Figure 5-9 LQFP80 Package Dimensions

Figure 5-10 LQFN80 Recommended Footprint⁽¹⁾

1. Dimensions are expressed in millimeters

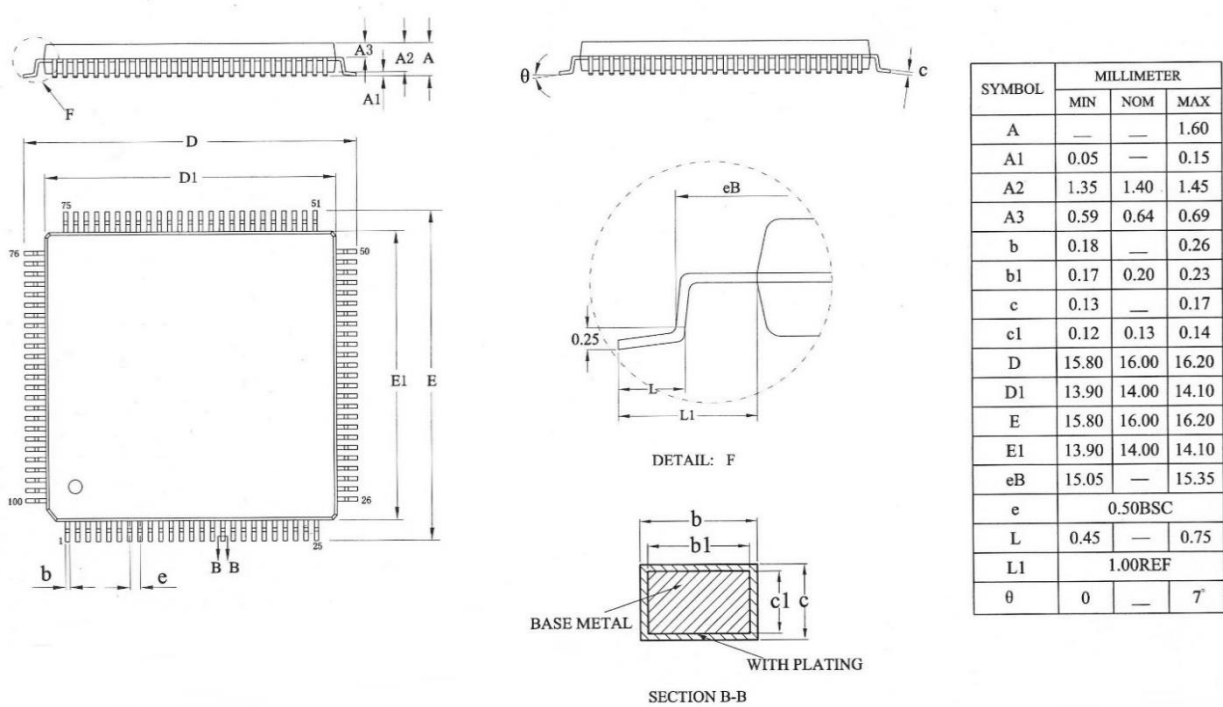
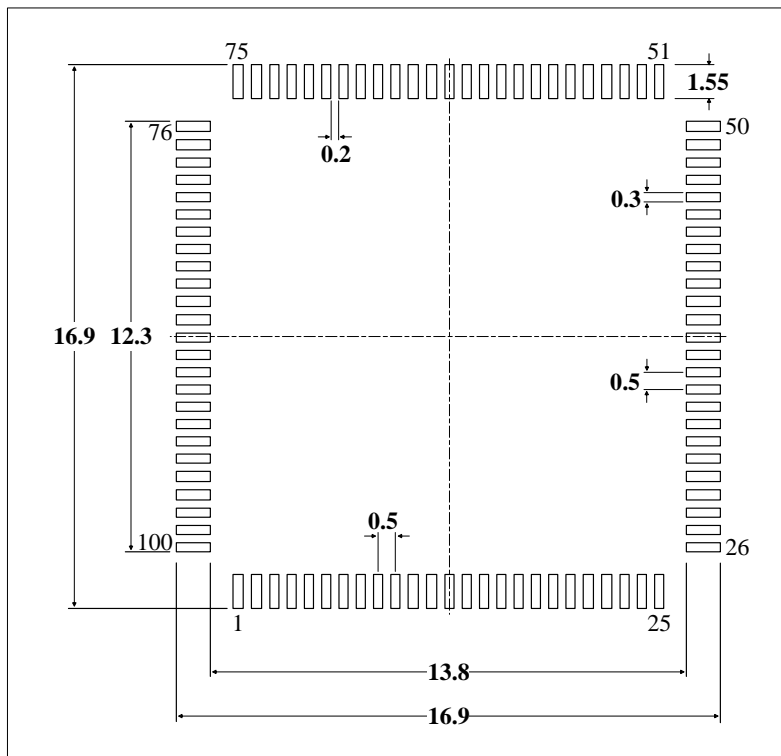
5.6 LQFP100

Figure 5-11 LQFP100 Package Dimensions

Figure 5-12 LQFN100 Recommended Footprint⁽¹⁾

1. Dimensions are expressed in millimeters

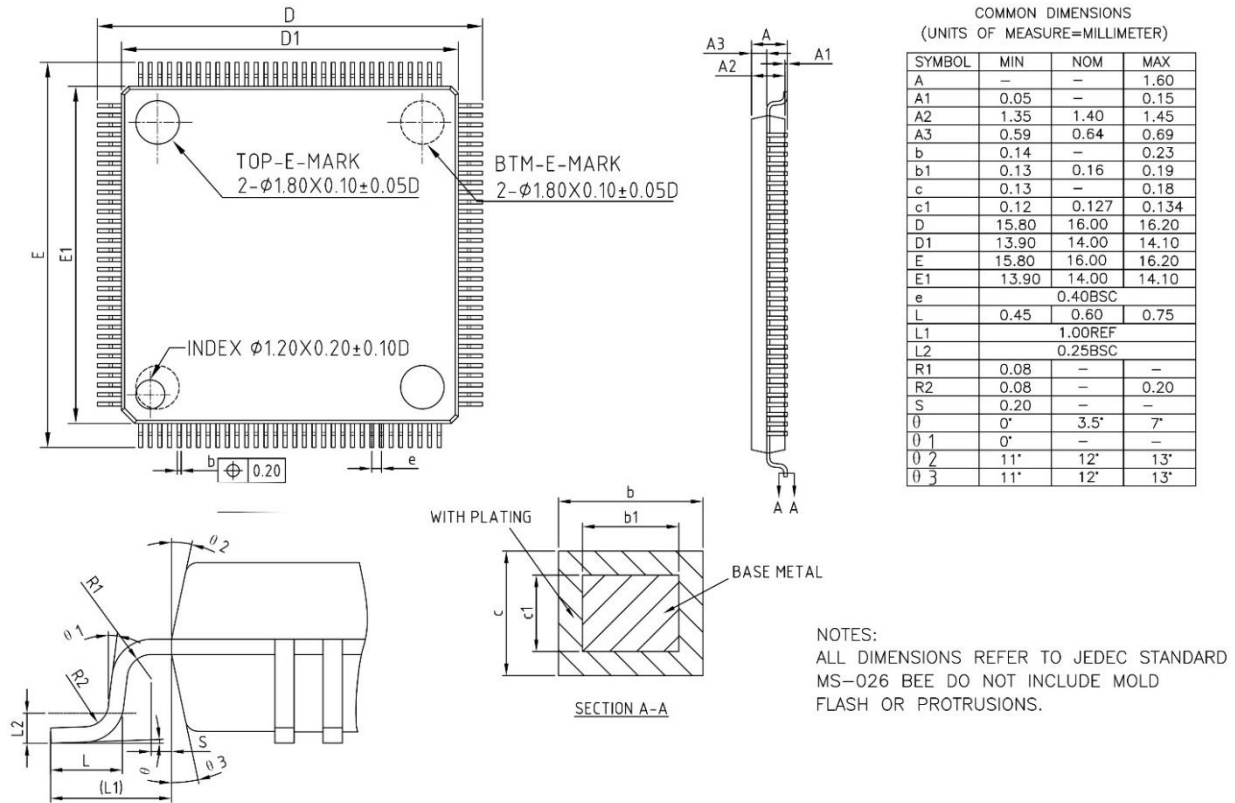
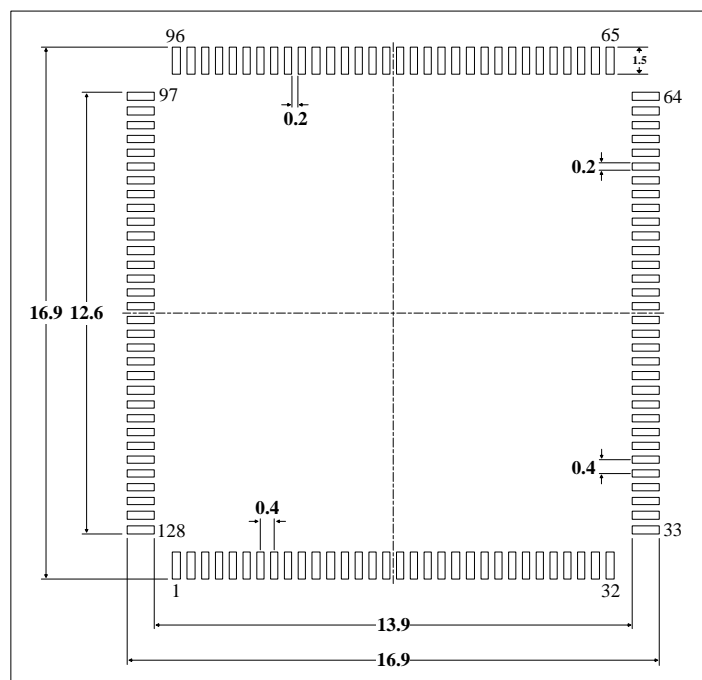
5.7 LQFP128

Figure 5-13 LQFP128 Package Dimensions

Figure 5-14 LQFN128 Recommended Footprint⁽¹⁾

1. Dimensions are expressed in millimeters

6 Marking Information

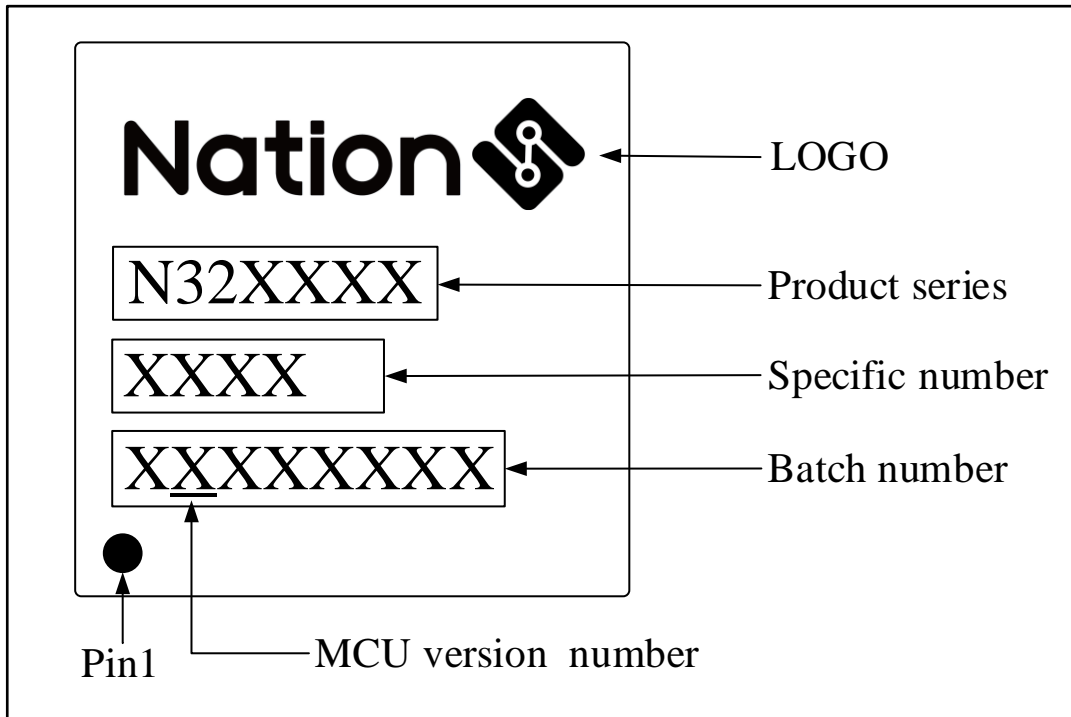
Figure 6-1 Marking Information



7 Ordering Information

7.1 Naming Convention

Figure 7-1 N32H474 Series Part Number Information

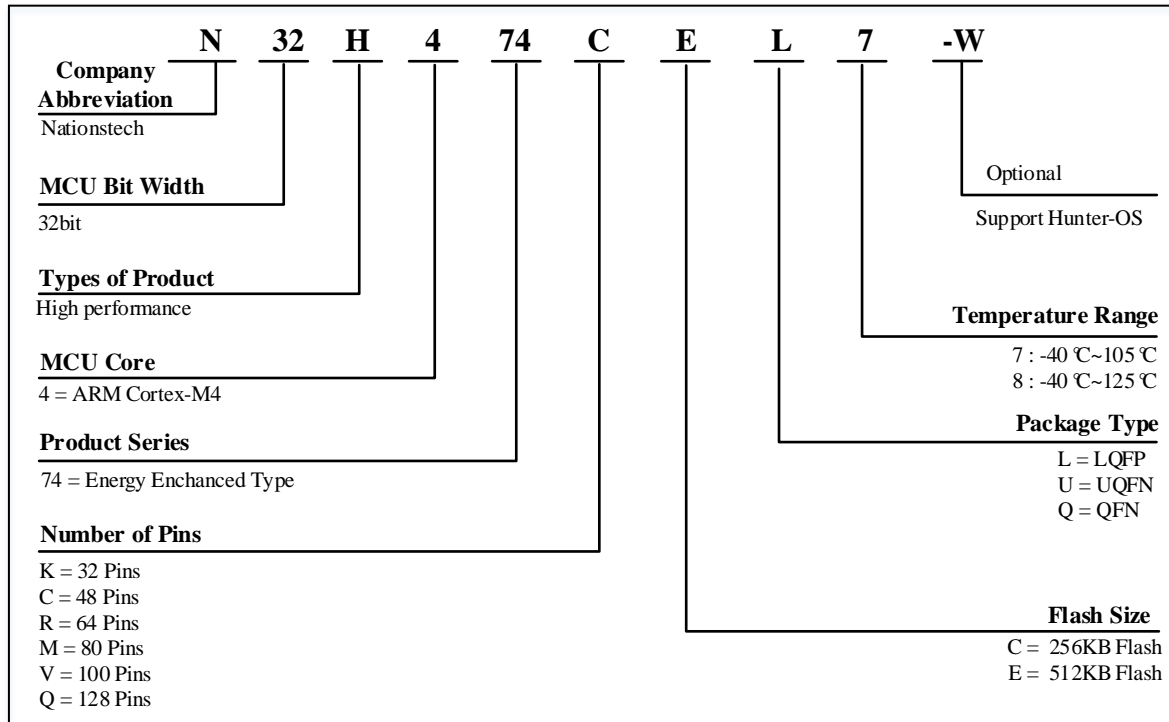

7.2 Ordering code

Table 7-1 N32H474 Series Ordering Code

Ordering Code ⁽¹⁾	Package	Size	Packaging ⁽²⁾	SPQ ⁽³⁾	Temperature range
N32H474KCQ7	QFN32	5mm x 5mm	Tray	490	-40°C ~ 105°C
N32H474CCU7	UQFN48	7mm x 7mm	Tray	260	-40°C ~ 105°C
N32H474CCL7	LQFP48	7mm x 7mm	Tray	250	-40°C ~ 105°C
N32H474RCL7	LQFP64	10mm x 10mm	Tray	160	-40°C ~ 105°C
N32H474MCL7	LQFP80	12mm x 12mm	Tray	119	-40°C ~ 105°C
N32H474VCL7	LQFP100	14mm x 14mm	Tray	90	-40°C ~ 105°C
N32H474QCL7	LQFP128	14mm x 14mm	Tray	90	-40°C ~ 105°C
N32H474KEQ7	QFN32	5mm x 5mm	Tray	490	-40°C ~ 105°C
N32H474CEU7	UQFN48	7mm x 7mm	Tray	260	-40°C ~ 105°C
N32H474CEL7	LQFP48	7mm x 7mm	Tray	250	-40°C ~ 105°C
N32H474REL7	LQFP64	10mm x 10mm	Tray	160	-40°C ~ 105°C
N32H474MEL7	LQFP80	12mm x 12mm	Tray	119	-40°C ~ 105°C
N32H474VEL7	LQFP100	14mm x 14mm	Tray	90	-40°C ~ 105°C
N32H474QEL7	LQFP128	14mm x 14mm	Tray	90	-40°C ~ 105°C
N32H474VEL7-W	LQFP100	14mm x 14mm	Tray	90	-40°C ~ 105°C
N32H474KCQ8	QFN32	5mm x 5mm	Tray	490	-40°C ~ 125°C

N32H474CCU8	UQFN48	7mm x 7mm	Tray	260	-40°C~125°C
N32H474RCL8	LQFP64	10mm x 10mm	Tray	160	-40°C~125°C
N32H474MCL8	LQFP80	12mm x 12mm	Tray	119	-40°C~125°C
N32H474VCL8	LQFP100	14mm x 14mm	Tray	90	-40°C~125°C
N32H474QCL8	LQFP128	14mm x 14mm	Tray	90	-40°C~125°C
N32H474KEQ8	QFN32	5mm x 5mm	Tray	490	-40°C~125°C
N32H474CEU8	UQFN48	7mm x 7mm	Tray	260	-40°C~125°C
N32H474REL8	LQFP64	10mm x 10mm	Tray	160	-40°C~125°C
N32H474MEL8	LQFP80	12mm x 12mm	Tray	119	-40°C~125°C
N32H474VEL8	LQFP100	14mm x 14mm	Tray	90	-40°C~125°C
N32H474QEL8	LQFP128	14mm x 14mm	Tray	90	-40°C~125°C

1. For the latest detailed-ordering information, please refer to the Selection Guide.
2. The packaging provided is the basic packaging. If user has any other requirements, please contact Naitons.
3. Minimum packaging quantity.

8 Version History

Version	Date	Changes
2024.11.12	V1.0.0	Initial release
2025.5.9	V1.1.0	<ol style="list-style-type: none"> 1. Section 2.29 Add notes on the use of SAC. 2. Table 4-3 Modify T_{STG} Characteristic Data 3. Table 4-12 Modify USBFS Power Consumption 4. Addition of models N32H474KEQ7/8 and N32H474KCQ7/8 5. Modify the WKUP pin number
2025.8.28	V1.2.0	<ol style="list-style-type: none"> 1. Modify the naming convention, - W model is optional, and this model supports Hunter-OS 2. Delete XSPI_RXDS reuse function of PC13 in section 3.2 3. Modify Table 4-40 LPTIM Maximum Possible Counting Characteristics 4. Modify the maximum core frequency to 240MHz at 105 °C and 200MHz at 125 °C 5. Modify Table 4-17 ACC_{HSI} characteristics

9 Disclaimer

This document is the exclusive property of NSING TECHNOLOGIES PTE. LTD. (Hereinafter referred to as NSING). This document, and the product of NSING described herein (Hereinafter referred to as the Product) are owned by NSING under the laws and treaties of Republic of Singapore and other applicable jurisdictions worldwide. The intellectual properties of the product belong to NSING Technologies Inc. and NSING Technologies Inc. does not grant any third party any license under its patents, copyrights, trademarks, or other intellectual property rights. Names and brands of third party may be mentioned or referred thereto (if any) for identification purposes only. NSING reserves the right to make changes, corrections, enhancements, modifications, and improvements to this document at any time without notice. Please contact NSING and obtain the latest version of this document before placing orders. Although NSING has attempted to provide accurate and reliable information, NSING assumes no responsibility for the accuracy and reliability of this document. It is the responsibility of the user of this document to properly design, program, and test the functionality and safety of any application made of this information and any resulting product. In no event shall NSING be liable for any direct, indirect, incidental, special, exemplary, or consequential damages arising in any way out of the use of this document or the Product. NSING Products are neither intended nor warranted for usage in systems or equipment, any malfunction or failure of which may cause loss of human life, bodily injury or severe property damage. Such applications are deemed, Insecure Usage'. Insecure usage includes, but is not limited to: equipment for surgical implementation, atomic energy control instruments, airplane or spaceship instruments, all types of safety devices, and other applications intended to supporter sustain life. All Insecure Usage shall be made at user's risk. User shall indemnify NSING and hold NSING harmless from and against all claims, costs, damages, and other liabilities, arising from or related to any customer's Insecure Usage Any express or implied warranty with regard to this document or the Product, including, but not limited to. The warranties of merchantability, fitness for a particular purpose and non-infringement are disclaimed to the fullest extent permitted by law. Unless otherwise explicitly permitted by NSING, anyone may not use, duplicate, modify, transcribe or otherwise distribute this document for any purposes, in whole or in part.