Design Guide

Design Guide for Hardware of N32WB03x Series Chips

Overview

This document is the summary of hardware design experiences of Bluetooth chips by Nations Technologies Inc. and is applicable to be hardware design references for N32WB03x series chips of the Company. It is the detailed specifications for chip hardware design, selection of some important components and cautions for PCB Layout.

NATIONS CONFIDENTIAL

Contents

1 SCHEMATIC DIAGRAM DESIGN.....	3
1. 1 SPECIFICATIONS ON POWER SUPPLY DESIGN OF SCHEMATIC DIAGRAM.....	3
1. 2 DIFFERENCES BETWEEN TWO POWER SUPPLY MODES	3
1. 3 REFERENCE SCHEMATIC DIAGRAM FOR DCDC POWER SUPPLY MODE	4
1. 4 REFERENCE SCHEMATIC DIAGRAM FOR LDO POWER SUPPLY MODE	5
1. 5 REFERENCE SCHEMATIC DIAGRAM FOR EXTERNAL CRYSTAL.....	6
1. 6 REFERENCE SCHEMATIC DIAGRAM FOR RESET CIRCUIT	6
1. 7 REFERENCE MINIMUM SYSTEM BOM TABLE	7
1. 8 REFERENCE SCHEMATIC DIAGRAM FOR MICROPHONE CIRCUIT	7
1. 9 REFERENCE SCHEMATIC DIAGRAM FOR INFRARED TRANSMITTER CIRCUIT	8
1. 10 REFERENCE SCHEMATIC DIAGRAM FOR CONDUCTION/RADIATION CERTIFICATION TEST.....	8
2 SPECIFICATIONS ON CHIP PINS IN THE SCHEMATIC DIAGRAM	9
2. 1 POWER SUPPLY PINS	9
2. 2 RF PINS	9
2. 3 CRYSTAL OSCILLATOR PINS	9
2. 4 DEBUG PINS	10
2. 5 AMIC AUDIO PINS	10
2. 6 IO INTERFACE.....	10
3 DESIGN SPECIFICATIONS ON PCB LAYOUT	11
3. 1 REQUIREMENTS FOR RF/IO WIRING DESIGN	11
3. 2 REQUIREMENTS FOR ROUTING OF 32MHZ CRYSTAL OSCILLATOR.....	13
3. 3 REQUIREMENTS FOR ROUTING OF CHIP GROUNDING	14
3. 4 REQUIREMENTS FOR POWER SUPPLY ROUTING	15
3. 5 REQUIREMENTS FOR AMIC AUDIO ROUTING	16
4 VERSION HISTORY	18
5 NOTICE	19

1 Schematic diagram design

1.1 Specifications on power supply design of schematic diagram

- 1) When the external power supply voltage is 1.8V/2.32V~3.6V, it can be directly connected to chip VCC.
- 2) VCCRF, from which the maximum supply is 3.6V, is recommended to be connected to VCC pin in parallel.
- 3) Note the chip GND pin is at the bottom of the chip, and be sure to connect the square bonding pad at the bottom of the chip to GND network for wiring. See Chapter 3.3 for details.

1.2 Differences between two power supply modes

Two power supply modes are available for chips, and the main differences between the two modes are set forth below:

Mode Parameters	DCDC power supply mode	LDO power supply mode
BOM difference	4.7uh inductor required	4.7uh inductor not required
Active power consumption	1.8 mA	3.8 mA
Power consumption in Sleep mode	1.6 uA	1.6 uA
RFTX power consumption	4 mA	8 mA
RFRX power consumption	3.8 mA	7.8 mA
RFRX sensitivity	-94 dBm	-95 dBm
RFRX maximum power	+8 dBm	+8 dBm

1. 3 Reference schematic diagram for DCDC power supply mode

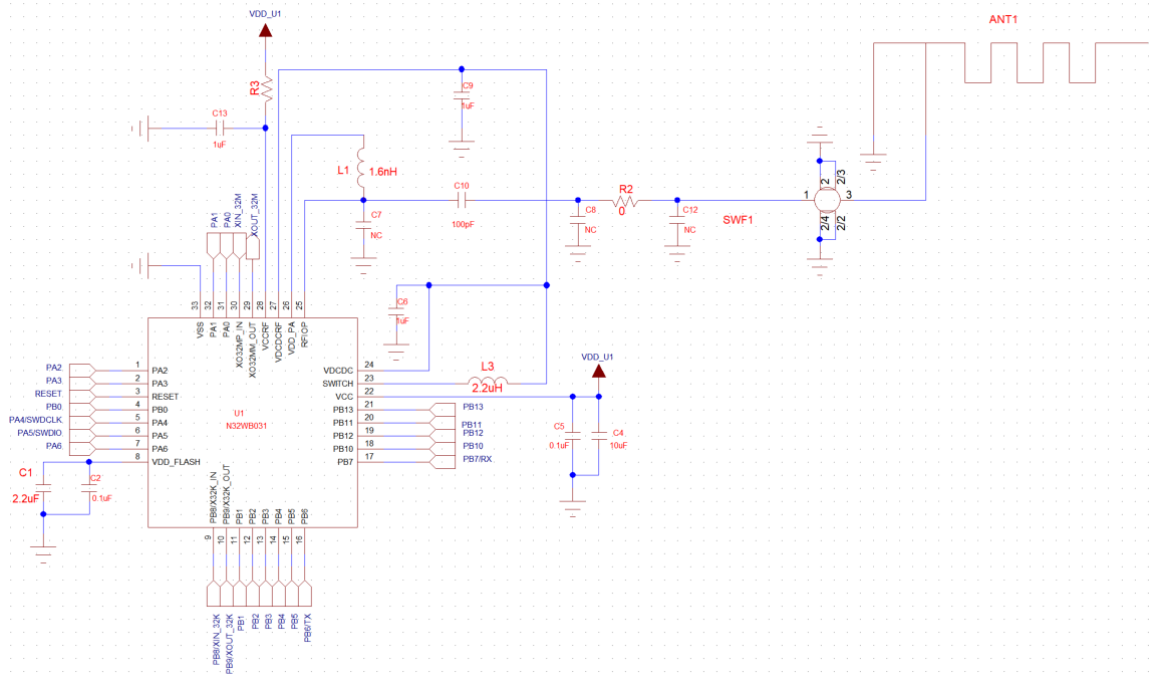

Fig. 1-1 Reference Schematic Diagram for DCDC Power Supply Mode

1. 4 Reference schematic diagram for LDO power supply mode

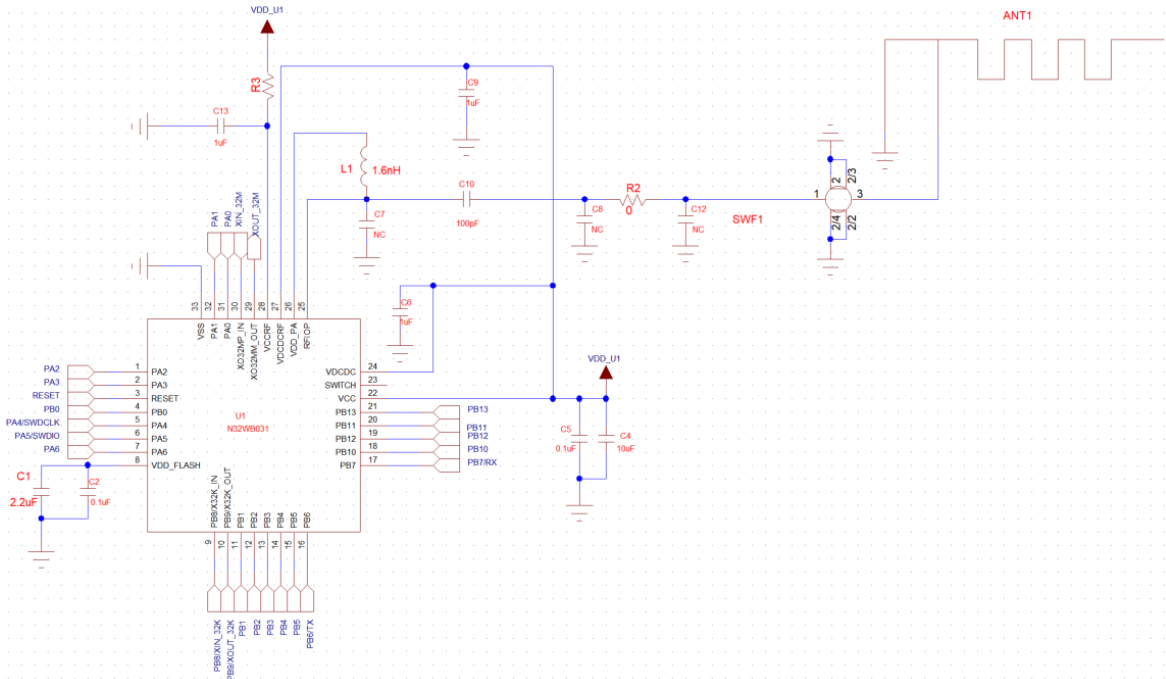

Fig. 1-2 Reference Schematic Diagram for LDO Power Supply Mode

1. 5 Reference schematic diagram for external crystal

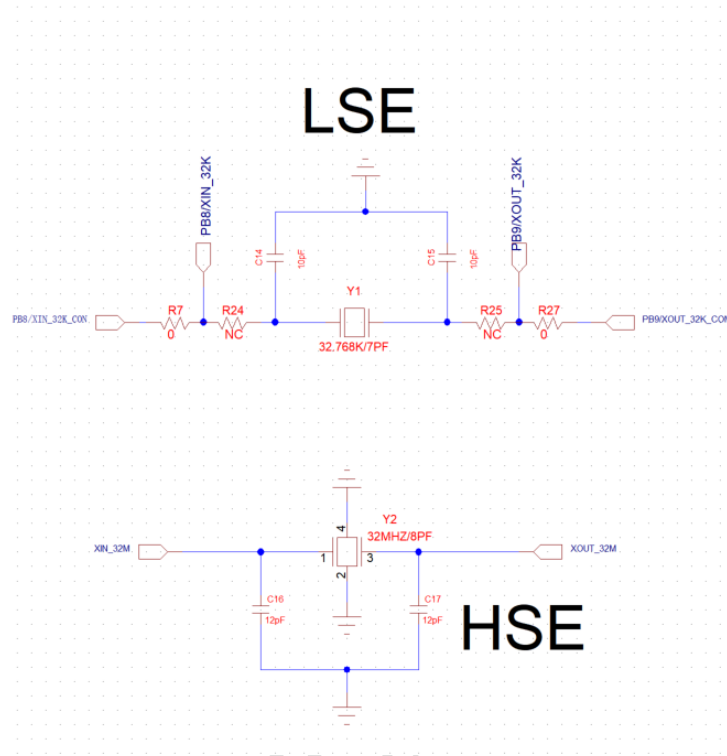

Fig.1-3 Reference Schematic Diagram for External Crystal

1. 6 Reference schematic diagram for reset circuit

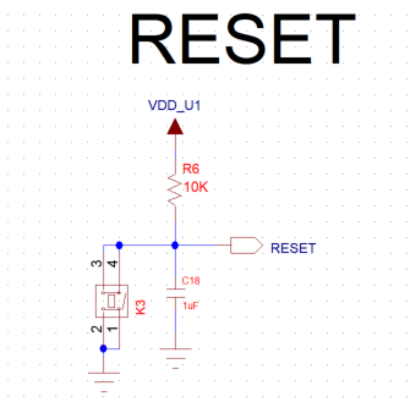

Fig. 1-4 Reference Schematic Diagram for Reset Circuit

1. 7 Reference minimum system BOM table

Item	Part Name	Description	REV	QTY	Reference
0001	CAP0402,105	CAP,CER,16V,1UF,X7R,10%,0402		3	C5,C9,C13
0002	CAP0402,104	CAP,CER,16V,0.1UF,X7R,10%,0402		12	C2,C6,C18,C22,C23,C25,C26, C27,C29,C34,C36,C38
0003	CAP0603,2.2uF	CAP,CER,10V,2.2UF,X7R,10%,0603		1	C1
0004	CAP0603,4.7uF	CAP,CER,10V,4.7UF,X7R,10%,0805		1	C28
0005	CAP0805,10uF	CAP,CER,10V,10UF,X7R,10%,0805		4	C24,C30,C33,C35
0006	CAP0603,10uF	CAP,CER,10V,10UF,X7R,10%,0603		1	C4
0007	CAP0402,10PF	CAP,CER,50V,10PF,COG,5%,0402		2	C14,C15
0008	CAP0402,12PF	CAP,CER,50V,12PF,COG,5%,0402		4	C16,C17,C20,C21
0009	CAP0402,47PF	CAP,CER,50V,47PF,COG,5%,0402		1	C10
0010	N32WB031_QFN32	IC,N32WB031,QFN32,32PIN		1	U1
0011	MAX8877-3.3V	IC,MAX8877EUK33,SMD,SOT23-5		1	U4
0012	XTAL_32.768KHz	XTAL,32,768KHz,7PF,20PPM,SMD_2012,-40 °C~ 125 °C		1	Y1
0013	XTAL_32MHz	XTAL,32MHz,8PF,10PPM,SMD_1612,4PIN,-40 °C~ 85 °C(NDK,NX1612A-32MHz-STD-CIS-3)		1	Y2
0014	INDUCTOR_4.7UH	INDUCTOR, 4.7UH,±20%, power inductor, RDC(direct-current resistance) 250mΩ, Heat Rating Current 800mA, 0805, (MPH201210S4R7MT,Sunlord)		1	L3
0015	INDUCTOR_1.6nH	INDUCTOR, 1.6nH,±0.3nH, high-frequency inductor, RDC(direct-current resistance) 100mΩ, Rated Current 300mA,0402, (SDCL1005C1N6STDF, Sunlord)		1	L1

Fig. 1-5 Reference BOM Table

1. 8 Reference schematic diagram for microphone circuit

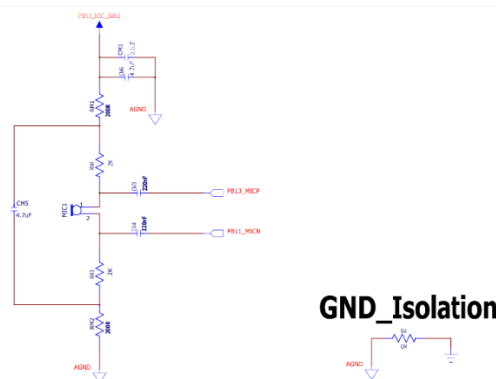

Fig. 1-6 Reference Schematic Diagram for Microphone Circuit

1. 9 Reference Schematic Diagram for Infrared Transmitter Circuit

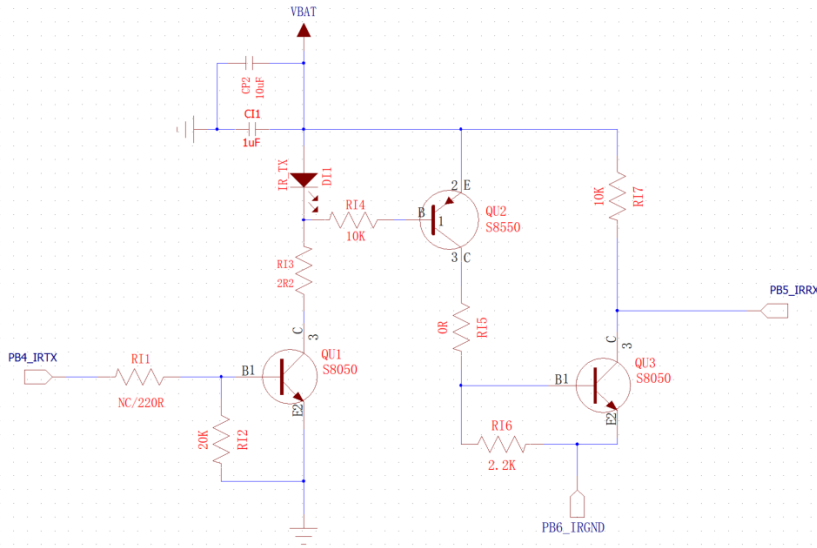

Fig. 1-7 Reference Schematic Diagram for Infrared Transmitter Circuit

1. 10 Reference Design for Conduction/Radiation Certification (CE/FCC) test

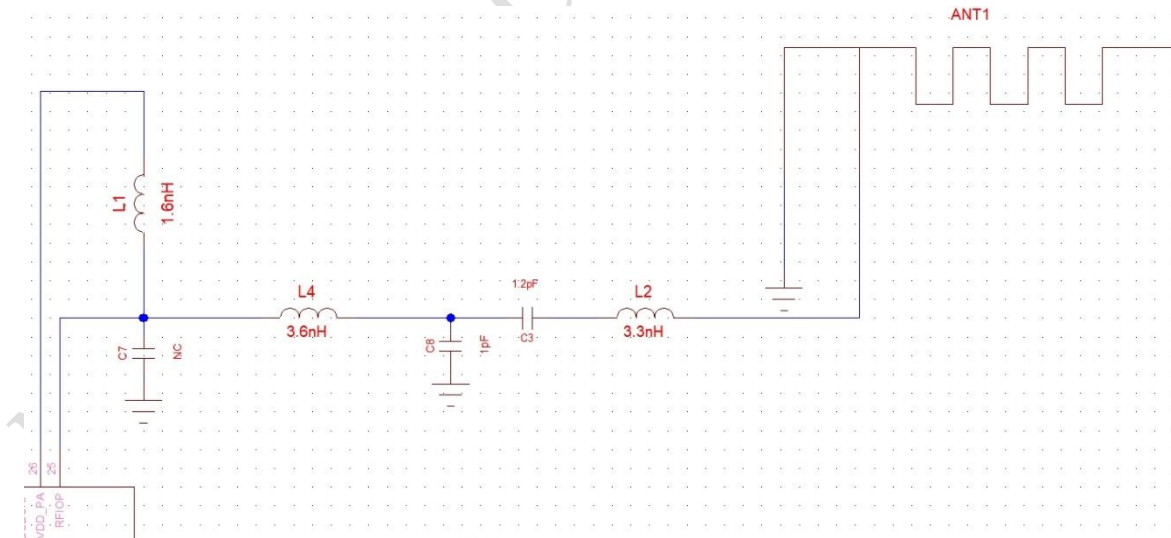

Fig. 1-8 Reference Schematic Diagram for Conduction/Radiation Certification(CE/FCC) test

2 Specifications on chip pins in the schematic diagram

2.1 Power supply pins

- PIN24(VDCDC) is the power supply pin receiving internal DCDC generated voltage, its typical voltage is 1.15V, it needs to be connected with 1uF decoupling capacitor, and 4.7uH power inductor needs to be provided in series between PIN24(VDCDC) pin and PIN23(SWITCH).
- PIN27(VDCDCRF) is the internal RF power supply pin receiving internal DCDC generated voltage, can be directly connected to PIN24(VDCDC), its typical voltage is 1.15V and it needs to be connected with 1uF decoupling capacitor.
- **PIN28(VCCRF) is external power supply pin**, needs to be connected with 1uF decoupling capacitor, and its external voltage range is **1.8V/2.32V~3.6 V**.
- PIN22(VCC) is external power supply pin, needs to be connected with 0.1uF and 4.7uF decoupling capacitors, and its external voltage range is 1.8V/2.32V~3.6V。
- PIN8(VDD_FLASH) is the internal FLASH power supply pin, needs to be connected only with 0.1uF and 2.2uF decoupling capacitors without external power supply.

2.2 RF pins

- PIN25(RFIOP) is RF pin.
- PIN26(VDD_PA) receives the bias voltage with a range of 0.9V~1.7V generated by internal RF_PA, depending on the internal register configuration, the transmit power is different, and the bias voltage generated is different

2.3 Crystal oscillator pins

- PIN29(XO32MM) and PIN30(XO32MP) are Bluetooth reference clock pins and need to be connected with 32MHz crystals. As the Bluetooth requirement for frequency

deviation is high, the frequency deviation of the crystal oscillators should be $\leq \pm 10\text{ppm}$.

Note that external 32MHz crystals must be provided for using the Bluetooth function.

- PIN9(XO32KP_IN) and PIN10(XO32KM_OUT) are low-frequency reference clock pins, can also be used as general purpose IO interfaces and need to be connected with 32.768KHz crystals when they are used as clock pins.

2. 4 Debug pins

- PIN5(PA4/SWDCLK) and PIN6(PA5/SWDIO) are SWD pins and can also be used as general purpose IO interfaces. When they are used as SWD pins, they can be used to download applications. PIN5(PA4/SWDCLK) needs to be connected to 10K pull-down resistor and PIN6(PA5/SWDIO) to 10K pull-up resistor.
- PIN16(PB6/TX) and PIN17(PB7/RX) are Uart serial port pins, and can also be used as general purpose IO interfaces. They can be used for print when being used as serial port pins.

2. 5 AMIC audio pins

- PIN20(PB11/AMIC_N) and PIN21(PB13/AMIC_P) are MIC input pins supporting single-ended input and differential input with adjustable gain.
- PIN19(PB12/AMIC_BIAS) is the pin for outputting MIC bias voltage, it outputs adjustable MICBIAS voltage with a range of 1.6~2.3V and a typical voltage of 2V.

2. 6 IO interface

- For the specific definition of IO interface, see *N32WB03x Datasheet*

3 Design specifications on PCB Layout

3.1 Requirements for RFIOP wiring design

- In order to ensure minimum loss, RF routing should be as short as possible, components should be as compact as possible, and RF routing should be as straight as possible and should not be right angle with the routing width and the space between the route and the peripheral GND equivalent to the recommended value 0.5mm. As PCB material and medium influence the RF routing impedance, the routing width and the space between the route and the peripheral GND can be adjusted properly to ensure RF routing impedance is 50Ω.
- The wires around RF must be enclosed by the earthing system, with the upper system connecting to the lower layer via GND holes.
- The zone around antenna front and back must be separated from other routes, to ensure the space between GND and the antenna is 3mm or above and no metal component is in the space.
- Normally, the antenna length is about 30mm, equivalent to 1/4 of the Bluetooth signal wavelength.
- In order to enhance ESD protection capacity, be sure to coat the antenna surface with a solder mask rather than exposing it to the outside, It's better to add another silk screen layer on the top of the antenna.
- Considering that the ESD in the production line of the PCB is not well controlled during the production period, it is required to add a TVS tube to the antenna port for protection. For products within a distance of 10m, the TVS tube can be replaced with a 0 ohm resistor to improve ESD protection capability. The position of the TVS tube or 0 ohm resistance is shown in the figure below.

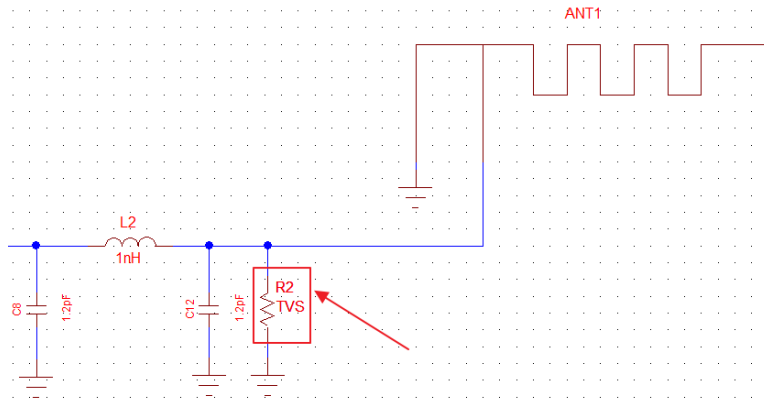

Fig. 3-1 Reference Schematic Diagram for TVS or Ohm resistor

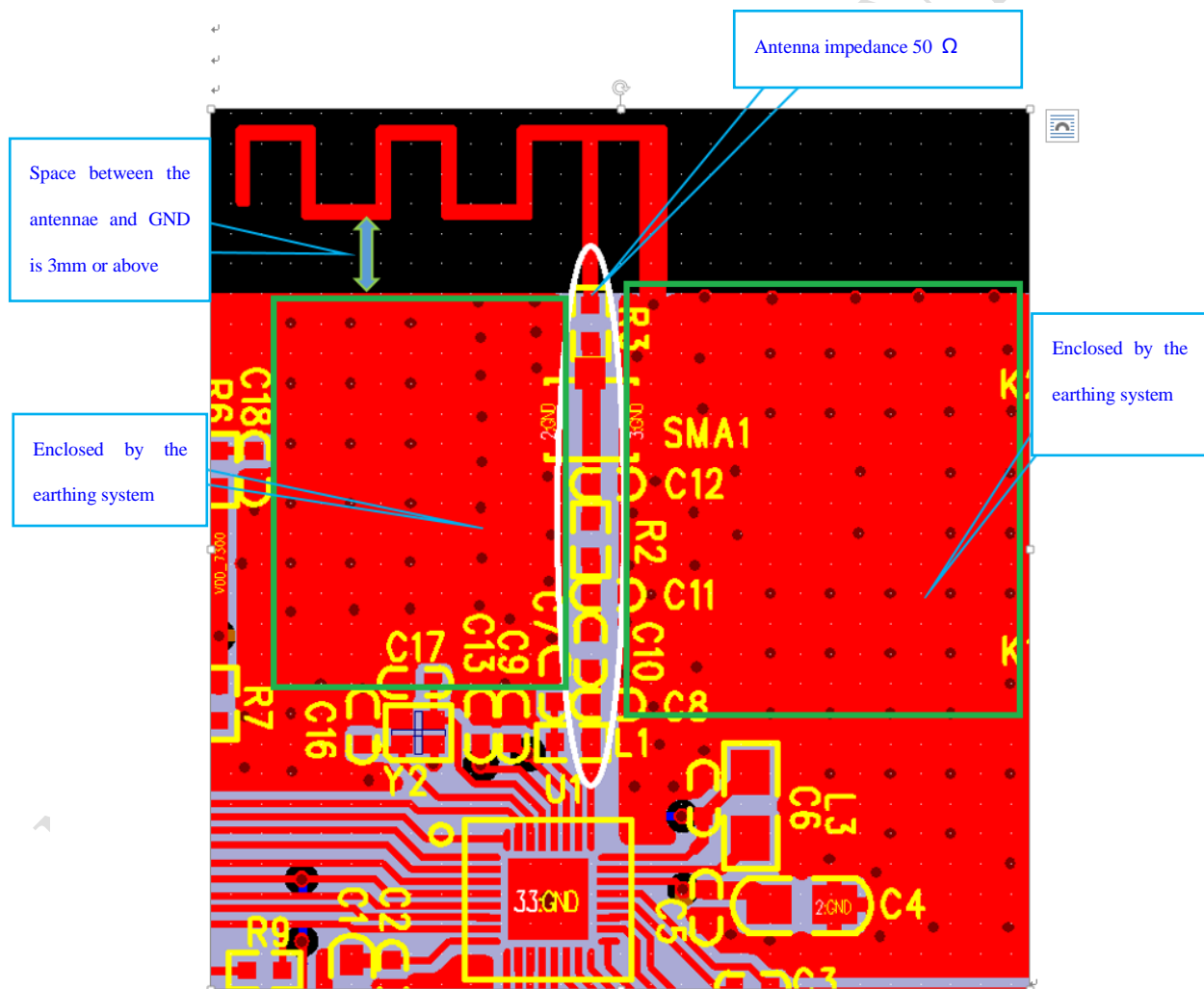
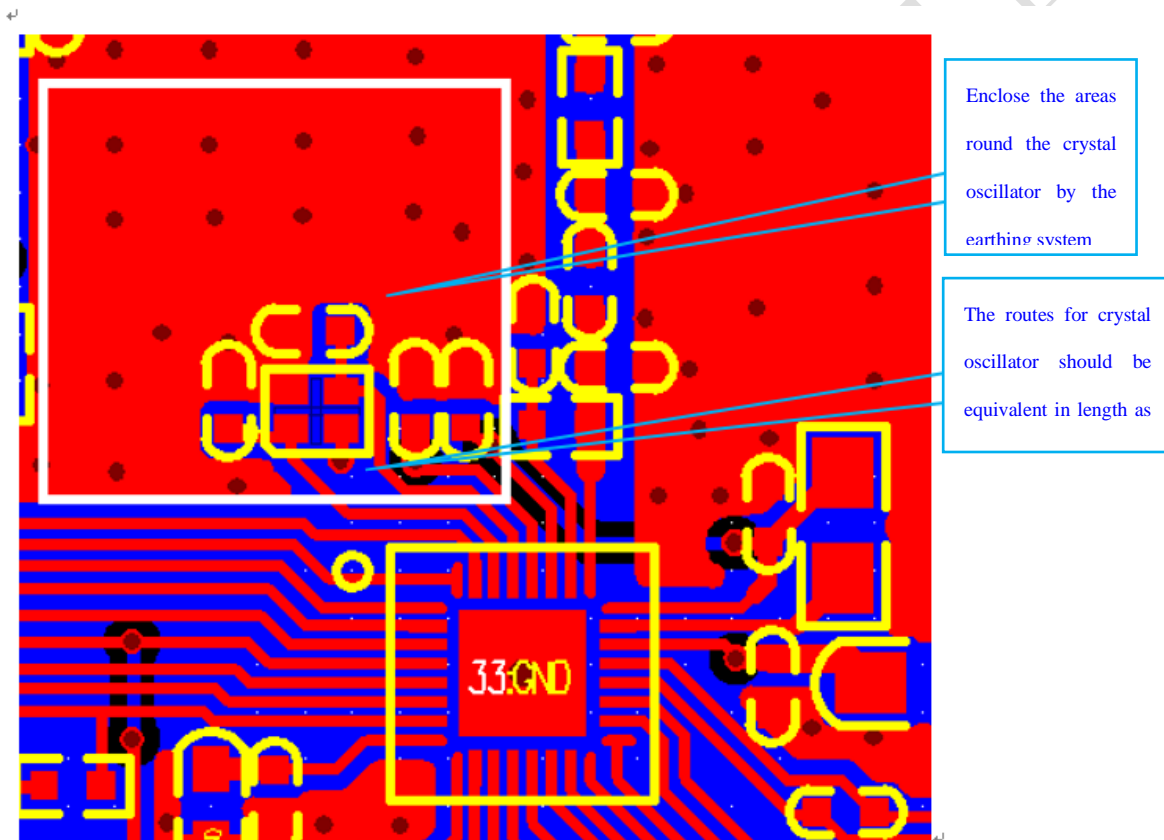

Fig. 3-2 Routing Layout for RF Antennae

3. 2 Requirements for routing of 32MHz crystal oscillator

- The two crystal oscillator routes should be as short as possible and as equivalent in length as possible, with the areas around them enclosed by the earthing system.
- Try not to route wires under the crystal oscillator, especially the VDCDCRF wires cannot be routed from below, as the DC voltage generated by Bluetooth broadcast affects the stability of the crystal oscillator frequency.



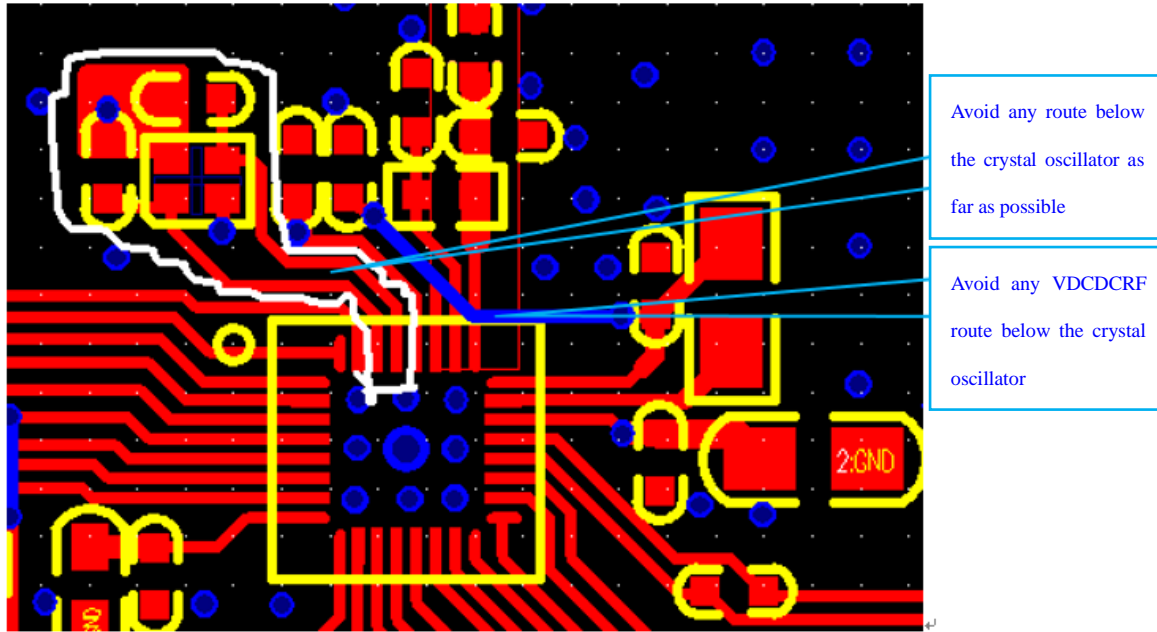

Fig. 3-3 Layout of 32MHz Crystal Oscillator

3. 3 Requirements for routing of chip grounding

- The 32 pins of this chip do not have GND, and its GND is at the bottom of the chip.
- The chip packaging center is required to be cladded by a square copper sheet. The space between the copper sheet and the chip pin should be $\geq 0.3\text{mm}$ and $\leq 0.5\text{mm}$, connect the copper sheet with GND via **9 holes**. The center hole may be 0.6mm/0.4mm and the holes around may be 0.5mm/0.3mm. The holes should not be too large to avoid tin leaking and consequent insufficient solder.

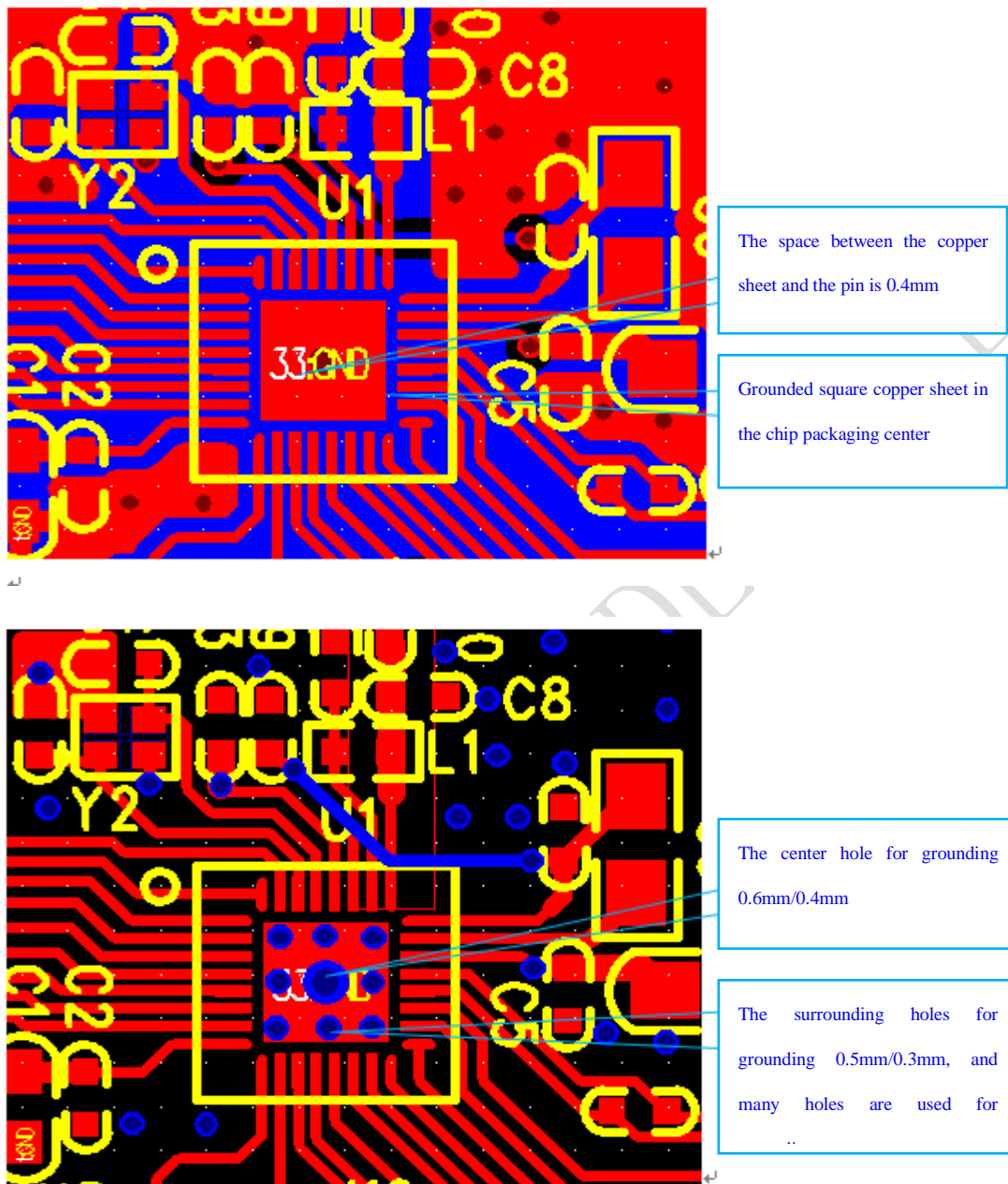

Fig. 3-4 Layout of Chip Ground Routing

3.4 Requirements for power supply routing

- The power supply wire for the chip should be as thick and short as possible, with the filter capacitor as close as possible to the chip.
- If two filter capacitors with difference capacity are used, the smaller one should be closer to the chip than the larger one.

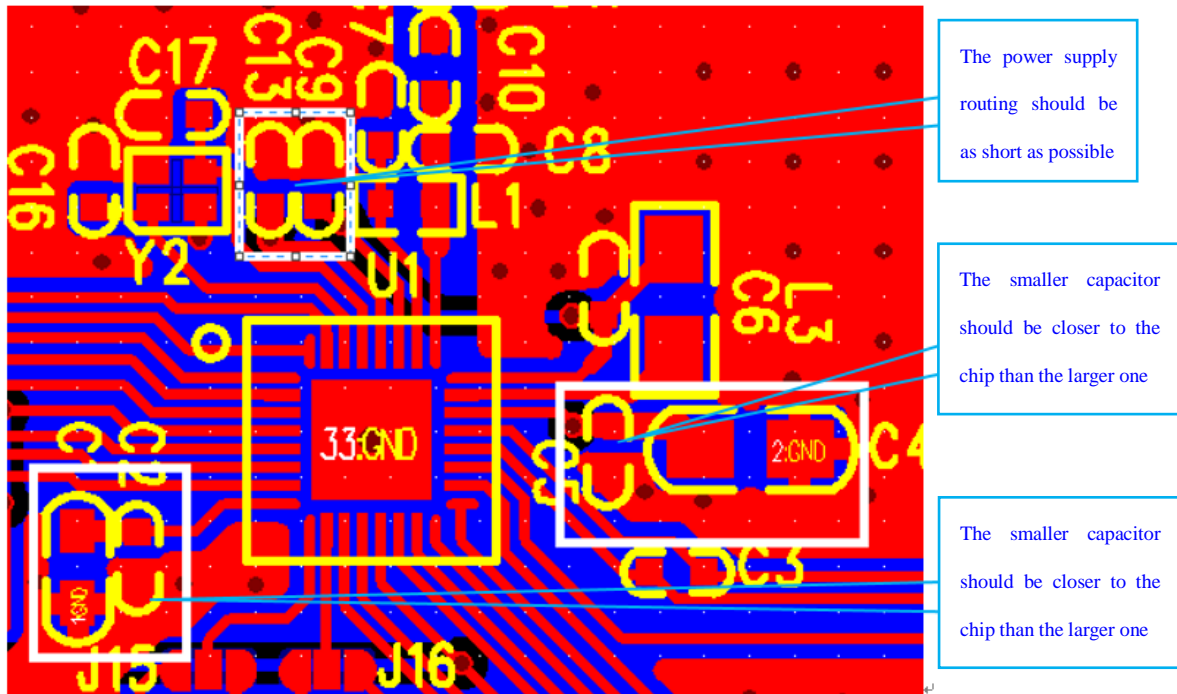

Fig. 3-5 Layout of Power Supply Routing

3. 5 Requirements for AMIC audio routing

- PB11/AMIC_N and PB13/AMIC_P support single-ended input and differential input, and their routes should be differential type. The differential wires should be as short and equivalent in spacing as possible, with proper shielding by ground wire for avoiding other signal interference.
- The inside of their audio module should be grounded first and then they are connected with the peripheral ground to avoid the interference from ground wire.

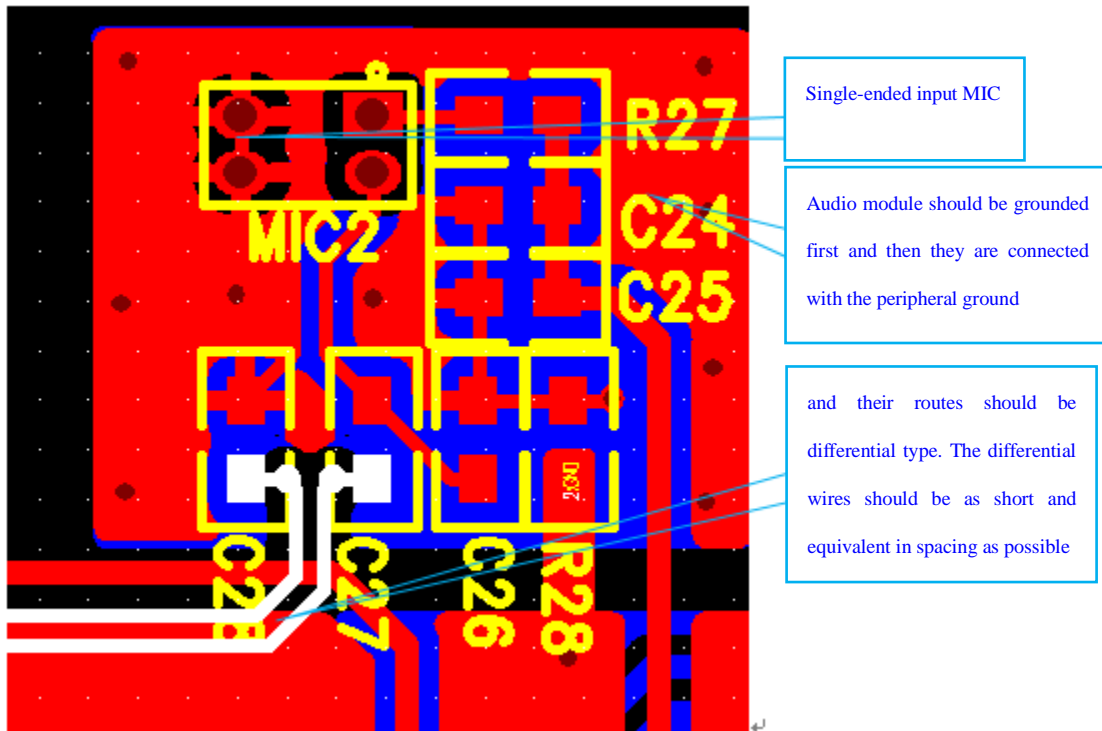
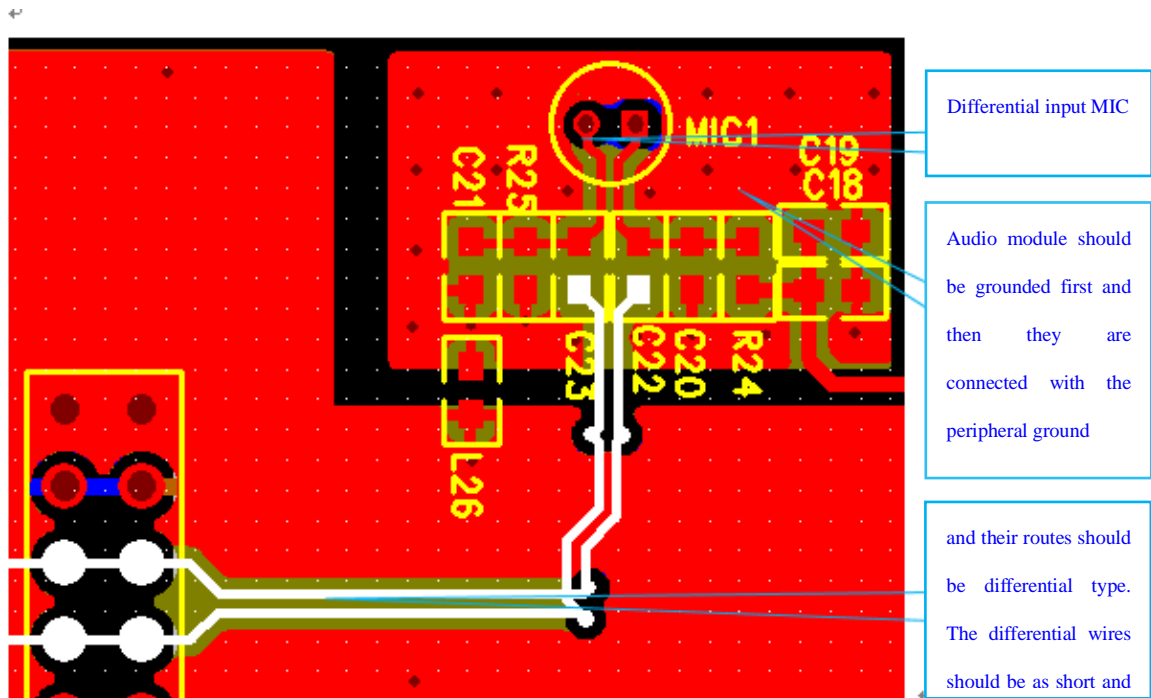

Fig. 3-6 Audio Routing Layout

4 Version history

Date	Version	Modifications	Author
2022/9/27	V1.3	Initial version	Joe Cai

NATIONS CONFIDENTIAL

5 Notice

This document is the exclusive property of Nations Technologies Inc. (Hereinafter referred to as NATIONS). This document, and the product of NATIONS described herein (Hereinafter referred to as the Product) are owned by NATIONS under the laws and treaties of the People's Republic of China and other applicable jurisdictions worldwide.

NATIONS does not grant any license under its patents, copyrights, trademarks, or other intellectual property rights. Names and brands of third party may be mentioned or referred thereto (if any) for identification purposes only.

NATIONS reserves the right to make changes, corrections, enhancements, modifications, and improvements to this document at any time without notice. Please contact NATIONS and obtain the latest version of this document before placing orders.

Although NATIONS has attempted to provide accurate and reliable information, NATIONS assumes no responsibility for the accuracy and reliability of this document.

It is the responsibility of the user of this document to properly design, program, and test the functionality and safety of any application made of this information and any resulting product. In no event shall NATIONS be liable for any direct, indirect, incidental, special, exemplary, or consequential damages arising in any way out of the use of this document or the Product.

NATIONS Products are neither intended nor warranted for usage in systems or equipment, any malfunction or failure of which may cause loss of human life, bodily injury or severe property damage. Such applications are deemed, "Insecure Usage".

Insecure usage includes, but is not limited to: equipment for surgical implementation, atomic energy control instruments, airplane or spaceship instruments, all types of safety devices, and other applications intended to support or sustain life.

All Insecure Usage shall be made at user's risk. User shall indemnify NATIONS and hold NATIONS harmless from and against all claims, costs, damages, and other liabilities, arising from or related to any customer's Insecure Usage.

Any express or implied warranty with regard to this document or the Product, including, but not limited to, the warranties of merchantability, fitness for a particular purpose and non-infringement are disclaimed to the fullest extent permitted by law.

Unless otherwise explicitly permitted by NATIONS, anyone may not use, duplicate, modify, transcribe or otherwise distribute this document for any purposes, in whole or in part.